



SIGNATURE OF QUALITY

AUTOMOTIVE PRODUCTS, INC.

INSTALLATION INSTRUCTIONS

APPLICATION: 2007-08 CHEVY SILVERADO 2500/3500HD SERIES

SPORTSMAN
ASSEMBLIES

40-2315
43-2310
45-2310

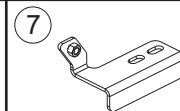
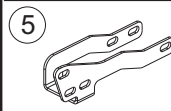
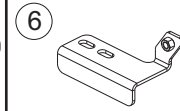
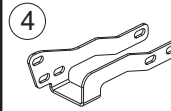
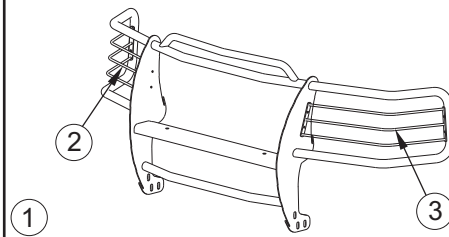

PARTS KIT CONTENTS

ITEM	QTY	DESCRIPTION	TOOLS REQUIRED
1	1	SPORTSMAN ASSEMBLY	3/4" SOCKET
2,3	2	LIGHT GUARD ASSEMBLY, PASSENGER(2) AND DRIVER (3)	3/4" WRENCH
4,5	2	BOTTOM BRACKET, PASSENGER (4) AND DRIVER (5)	7/16" WRENCH
6,7	2	BOTTOM SUPPORT BRACE, PASSENGER (6) AND DRIVER (7)	18MM SOCKET
8	8	BOLT PLATE ASSEMBLY	18MM WRENCH
9	6	1/2-13 X 1.25" HEX HEAD BOLT, STAINLESS STEEL	5/32" HEX WRENCH
10	12	1/2" FLAT WASHER, STAINLESS STEEL	FLAT TIP SCREWDRIVER
11	6	1/2" LOCK WASHER, STAINLESS STEEL	RATCHET
12	6	1/2-13 HEX NUT, STAINLESS STEEL	SOCKET EXTENSION
13	2	1/2-13 X 1.25" HEX HEAD BOLT, YELLOW ZINC	TORQUE WRENCH
14	10	1/2" FLAT WASHER, YELLOW ZINC	UTILITY KNIFE
15	10	1/2" LOCK WASHER, YELLOW ZINC	
16	8	1/2-13 HEX NUT, YELLOW ZINC	
17	2	15" ANTI-REFLECTIVE TAPE (CHROME ASSEMBLIES ONLY)	
NOTE: May not use all fasteners supplied in the bolt kit.			

- STEP 1. Remove the contents from box and check for damage. Verify all parts are present. Read instructions completely before beginning.
- STEP 2. Attach light guard assemblies as shown. **SEE FIGURE 1.**
- STEP 3. Remove tow hooks by removing the front bolt that bolts through the tow hooks and the rear bolt that threads into the bottom of the tow hooks. The tow hooks will not be reinstalled.
- STEP 4. Slide two bolt plates through the end of the frame and allow them to drop through the hole locations as shown. **SEE FIGURE 2.** Determine passenger and driver side support braces. Attach the support braces to the bottom surface of the frame using 1/2" yellow zinc fasteners. Make sure the tab with the weld nut is even with the inside face of the frame. Leave loose. **SEE FIGURE 3.**
- STEP 5. Determine passenger and driver side brackets. Slide bracket in through the tow hook pocket. Align slots on bracket with holes on frame. Slide the two bolt plates inside the frame and out through aligned holes on both sides of the frame. Secure with 1/2" yellow zinc fasteners. Leave loose. It may be necessary to trim the fascia around the tow hook area in order to properly align the brackets. **SEE FIGURES 4 AND 5.** The 1/2-13 X 1.25" hex head bolt will attach the bottom bracket to the support brace.
- STEP 6. Attach Sportsman to brackets using 1/2" stainless steel fasteners. **SEE FIGURE 5.** Center and level Sportsman on vehicle and tighten all fasteners. Recommended torque values are 43 Ft.Lbs. for 1/2" stainless steel fasteners and 64 Ft.Lbs. for 1/2" yellow zinc fasteners.
- STEP 7. For chrome assemblies. If light glare is being experienced off the wings of the Sportsman, anti-reflective tape has been supplied to reduce glare. With headlights on, note where the reflection is concentrated on the wing. Clean the wing well with a non-abrasive cleaner (rubbing alcohol works the best.) Trim the anti-reflective tape to the appropriate size where the glare was located and apply tape. **SEE FIGURE 1.**

ITEM	QTY.	DESCRIPTION
1	8	1/4-20 X 1.00" BUTTON HEAD BOLT
2	8	1/4" FLAT WASHER
3	4	1/4" INTERNAL TOOTH LOCK WASHER
4	4	1/4-20 NYLON NUT
5	8	RUBBER WASHER

NOTE: ALL FASTENERS MAY NOT BE USED.

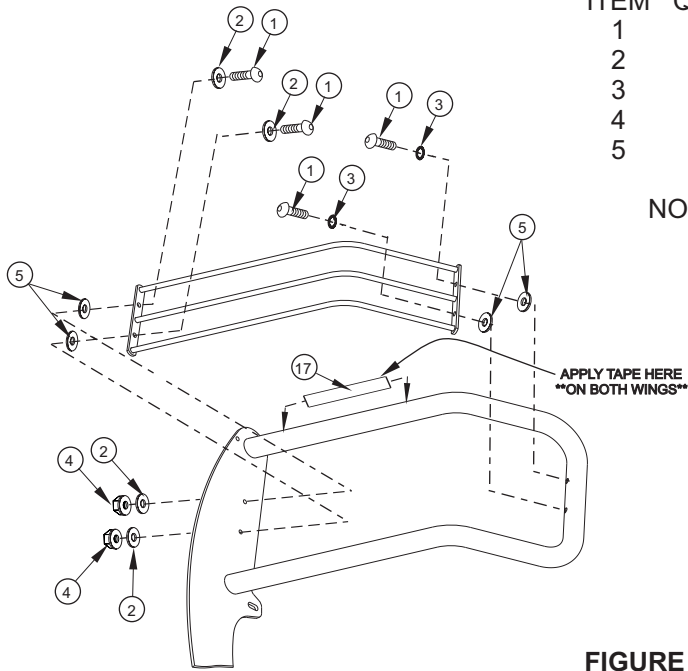

FIGURE 1
LIGHT GUARD INSTALLATION.

FIGURE 2
BOLT PLATE INSTALLATION, DRIVER SIDE SHOWN.

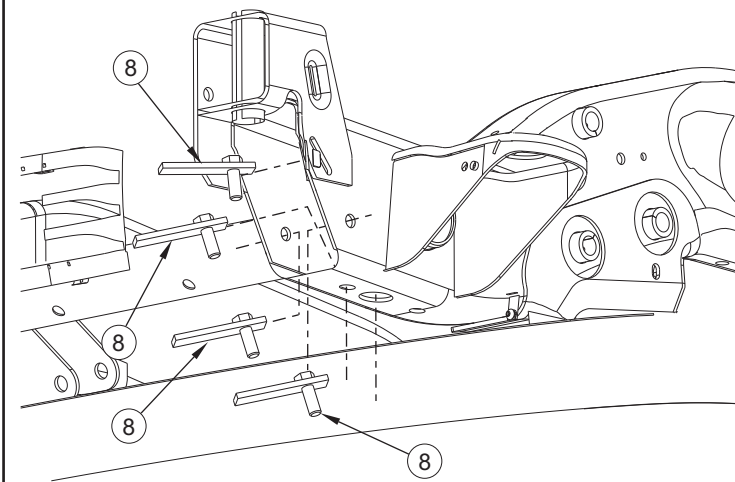

FIGURE 3
BRACKET INSTALLATION, DRIVER SIDE SHOWN.

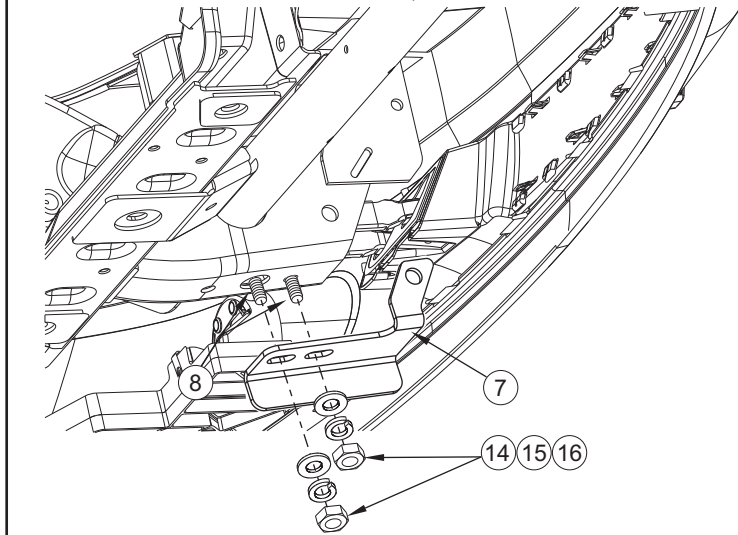

FIGURE 4
BRACKET ASSEMBLY INSTALLATION, DRIVER SIDE SHOWN.

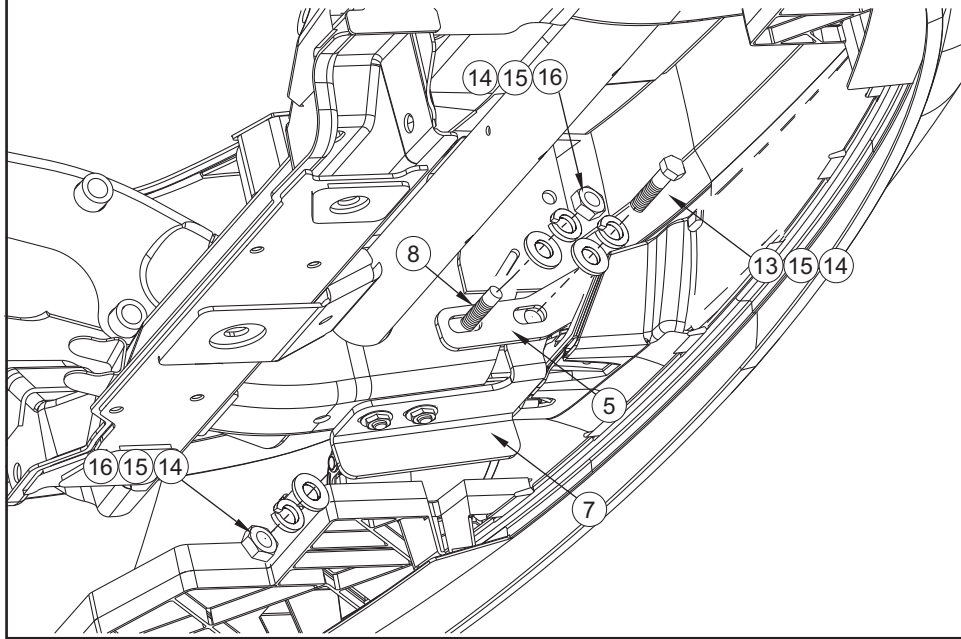

FIGURE 5
SPORTSMAN INSTALLATION.

