

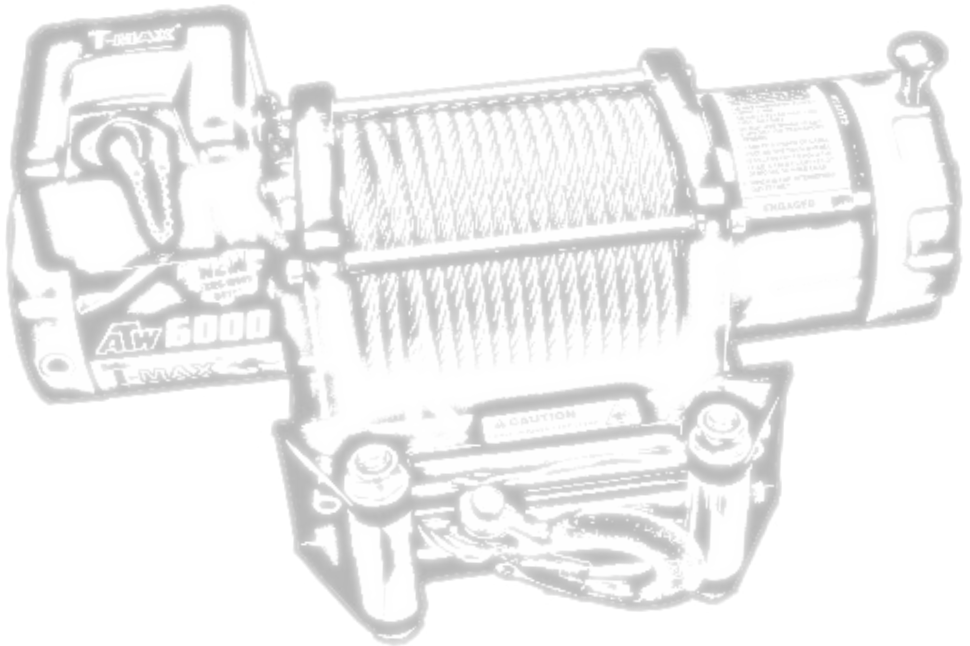

MAXIMUM OFF-ROAD RECOVERY.™

FITTING INSTRUCTIONS

ATW 6000



CONTENTS

- 12V 7305100 Non-Radio Control (Wire Rope)
- 12V 7305101 Radio Control (Wire Rope)
- 12V 7305110 Non-Radio Control (Synthetic Rope)
- 12V 7305111 Radio Control (Synthetic Rope)

INTRODUCTION

Thanks for your interesting in T-MAX Products, especially the ATW6000, and we sincerely hope that it will satisfy you. We not only have the professional capability to design winches but also with comprehensive after-sale service. Please do not hesitate to contact us for any further messages or suggestions.

Please do tell us the following information when you need to replace any parts of winch:

1. The series no. of winch, for instance 88808290001 which is shown no the top of the winch base.
2. The item no. of winch spare parts which is listed on the table of winch spare parts.
3. The exactly description of winch spare parts.

GENERAL SAFETY PRECAUTIONS

Please read and understand this owner's manual before installing and using your new winch. Pay particular attention to the General Information. Your winch is a very powerful machine. If used unsafely or improperly, there is a possibility that property damage or personal injury could result. We have included several features in this winch to minimize this possibility. However, your safety ultimately depends on your caution when using this product.

As the operator of this product the responsibility for safe operation ultimately lies with you. It is imperative that you read and understand all of the safety precaution instructions prior to installing and operation your winch. Failure to understand the proper operation of this product can result in serious injury and/or property damage.



DANGER Indicates a hazardous situation which, if not avoided, will result in death or serious injury.



WARNING Indicates a potentially hazardous situation which, if not avoided, will result in death or serious injury.



CAUTION Indicates a potentially hazardous situation which, if not avoided, may result in minor or moderate injury. The notation is also used to alert you to unsafe practices.



Note:

1. The above symbols in the Owner's manual are used to indicate additional information in the installation and operation procedures.
2. ATW6000 is designed primarily for intermittent duty general use. This winch is not designed to be used in industrial or hoisting applications. ATW6000 does not warrant it to be suitable for such use. T-MAX manufactures a separate line of winches for industrial/commercial use. Please contact us for further information.

UNPACKING

This carton contains the following items. Please unpack carefully.

Packaging list of ATW6000

Description	Qty	Remark
ATW6000, W/ WIRE ROPE or W/SYNTHETIC ROPE	1	
HAND CONTROL	1	Without Radio; Two kinds of hand control are optional.
ROCKER SWITCH	1	
CONTROL BOX	1	
RADIO HAND CONTROL	1	Radio Version.
RADIO CONTROL BOX	1	
ROLLER FAIRLEAD or ALUMINUM FAIRLEAD	1	
MOUNTING HARDWARE KIT	1	
OWNER'S MANUAL	1	
MOUNTING PLATE	1	
LONG CABLE	2	
SHORT CABLE	3	

6000LBS WINCH PARTS LIST

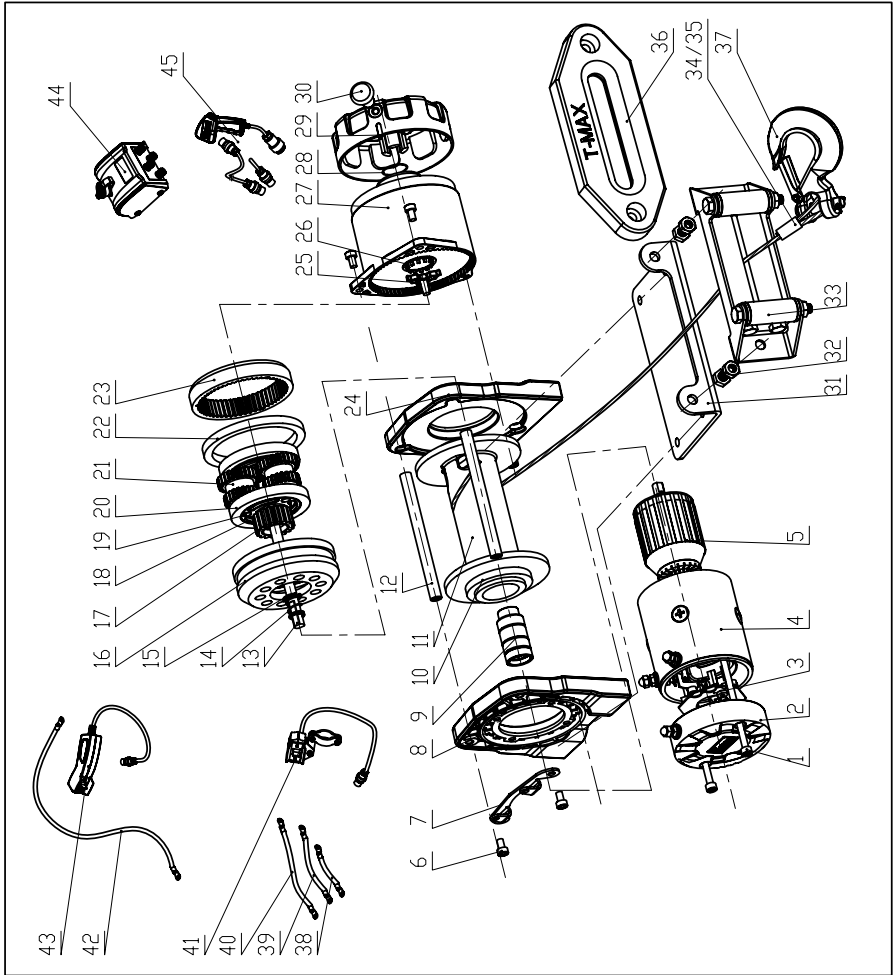

EXPLODED VIEW OF ATW6000

Item	Part No.	Description	Qty
1	GB/T70 M6x120	Bolt M6 X 120	2
2	7305100.1.1-1	Motor End Cover	1
3	7241100.1.1.3.1	Carbon Assy	1
4	7241100.1.1	Stator	1
5	7241100.1.2	Rotor	1
6	GB/T-85 M6x18	Bolt M6X18	4
7	7305100.0-1	Control Box Mount Bracket	1
8	7305100.1-1	Motor Base	1
9	7305100.0-4	Coupling Joint	1
10	GB/T276-1994	Bearing	2
11	7305100.2	Drum Assy	1
12	7305100.0-2	Tie Rod	2
13	7241100.3-9	Sun Gear	1
14	7241100.0-3	Spring	1
15	7241100.8-7	Washer	1
16	7241100.3-3	Inner Gear- Output	1
17	7241100.5	Braking System	1
18	7241100.3.1-4	Gear Spindle	3
19	7241100.3.1-1	Gear Carrier	2
20	GB/T276-1994 61812	Bearing	2
21	7241100.3.1-3	Planetary Gear	3
22	7241100.3-4	Anti-friction Gasket	1
23	7241100.3-5	Inner Gear	1
24	7305100.3-1	Motor Base	1
25	7241100.3-8	Clutch Yoke	1
26	7241100.3-7	Inner Lock washer	1
27	7241100.3-2	Gear Box Tube	1
28	GB/T3452.1 23.6x1.80	O Ring	1
29	7305100.3-3	Clutch Cover	1
30	7305100.3-2	Clutch Handle Assy	1
31	7241100.0-2	Mounting Plate	1
32	GB/T5782-2000 M8x20	Bolt M8 X20	2
33	7241100.4	Roller Fairlead(match to Wire Rope)	1
34	7241100.7	Wire Rope	1
35	9163151	Synthetic Rope	1
36	7309200.7-2	Aluminum Fairlead(match to Synthetic Rope)	1
37	RU104206	Clevis Hook	1
38	7241100.6-1	Short Black Cable (25mm ² x 5cm) (wrapped by Black Thermoplastics Pipes)	1

39	7241100.6-2	Short Black Cable (25mm ² x 10cm) (wrapped by Red Thermoplastics Pipes)	1
40	7241100.6-3	Short Black Cable (25mm ² x 10cm) (wrapped by Yellow Thermoplastics Pipes)	1
41	7241100.6.2 (W)	Control for ATV Use (match to Wire Rope)	1
	7241100.6.2 (S)	Control for ATV Use (match to Synthetic Rope)	1
42	7241100.6-4	Long Cable (25mm ² x 180cm)	2
43	7241100.6.3 (W)	Remote Handle Control for UTV & Utility Use (match to Wire Rope)	1
	7241100.6.3 (S)	Remote Handle Control for UTV & Utility Use (match to Synthetic Rope)	1
44	7241100.6.4 (W)	Control Box Assy(match to Wire Rope)	1
	7241100.6.4 (S)	Control Box Assy(match to Synthetic Rope)	1
45	7241100.6.5	Radio Hand Control	1

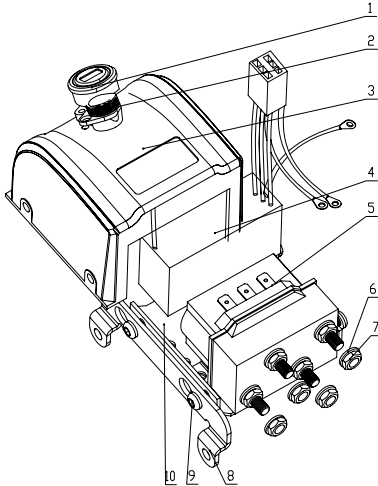

EXPLODED VIEW OF ATW6000's CONTROL BOX			
No.	Part No.	Description	Qty
1	7329200.6A-10	Plug Cover	1
2	7329200.6A-11	Socket	1
3	7241100.6.5-1	Mini box	1
4	7241100.6.5-2	Radio Sender & Receiver	1
5	7241100.6.1	ISM	1
6	GB/T93 6	Washer	8
7	GB/T41 M6	Nut	8
8	7241100.6.5-3	Mounting Plate	1
9	GB/T 70.2 M5x10	Bolt	8
10	7241100.6.5-4	Control Box soleplate	1

DEMENSION

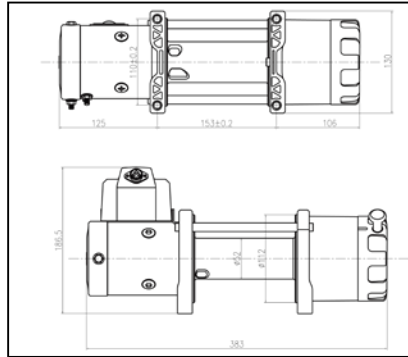

Note: The unit of dimension is mm.

Features & Specifications:

P/N: 7305101(Radio Control)

P/N: 7305100(Non-Radio Control)

Rated Line Pull: 6000 lbs (2720kgs) Single-line

Motor: 12V , 1.3HP (Series Wound)

Control: Radio Control / Remote Control

Gear Ratio: 148:1

Clutch: Turn 90°By Hand wheel

Barking: Eccentric Block Type

Drum Size: Diameter 2.08" (53mm) x Length 5.33" (128mm)

Recommended Battery:650CCA Minimum for Winching

Fairlead: Roller Fairlead

Wire Rope: Length x Diameter (18mX6.8mm)

Mounting Bolt Pattern: 6.02" (153mm) x 4.33"(110mm)

Weight: 17KGS(37.5Lbs)

Overall Dimensions: (LxWxH) 15.08"x5.12"x7.32"(383mm x 130mm x186mm)

P/N: 7305111(Radio Control)

P/N: 7305110(Non-Radio Control)

Rated Line Pull: 6000 lbs (2720kgs) Single-line

Motor: 12V , 1.3HP (Series Wound)

Control: Radio Control / Remote Control

Gear Ratio: 148:1

Clutch: Turn 90°By Hand wheel

Barking: Eccentric Block Type
 Drum Size: Diameter 2.08" (53mm) x Length 5.33" (128mm)
 Recommended Battery: 650CCA Minimum for Winching
 Fairlead: Aluminum Fairlead
 Synthetic: Length x Diameter (15m x 7.5 mm)
 Mounting Bolt Pattern: 6.02" (153mm) x 4.33" (110mm)
 Weight: 15KGS (33Lbs)
 Overall Dimensions: (LxWxH) 15.08"x5.12"x7.32" (383mm x 130mm x 186mm)

Line Pull lbs (kgs)	Line Speed ft/min (m/min)	Motor Current Amps
0	39.4 (12)	40
1000 (454)	21.3 (6.5)	100
1500 (680)	14.8 (4.5)	120
2000 (907)	11.2 (3.4)	140
2500 (1134)	8.9 (2.7)	160
3000 (1360)	7.5 (2.3)	170
3500 (1587)	6.2 (1.8)	190
4000 (1814)	5.6 (1.7)	200
4500 (2040)	5 (1.6)	220
5000 (2270)	4.9 (1.5)	230
5500 (2500)	4.6 (1.4)	260
6000 (2720)	4.3 (1.3)	280

Above performance specs are based on first layer of drum

Wire rope layer	Pulling power lbs (kgs)	Cable Capacity per Layer ft(m)
1st is closest to drum		
1st	6000 (2720)	11(3.4)
2nd	4850 (2200)	25(7.6)
3rd	4070(1850)	41(12.5)
4th	500 (1260)	59(18)

INTERMITTENT DUTY

ATW6000 is like any other motor driver power tools such as an electric drill or saw. The electric motor should not be allowed to become excessively hot. Normally precautions will extend the life of your motor. Keep the duration of pulls as short as possible. If the end of the motor becomes uncomfortable hot to touch, stop winching and allow the motor to cool down.



If the winch motor stalls, do not continue to apply power to the winch.

GERNERAL SAFTEY PRECAUTIONS

ATW6000 is a powerful machine. Treat it with respect, use it with caution and always follow the safety guidelines.



The wire rope or synthetic rope before the winch stalls. For heavy loads, use a pulley block to reduce the load on the wire rope.

1. Maximum working load capacity is on the first layer closest to the drum is around 6000lbs (2040kgs). Do not overload. Do not attempt prolonged pulls at heavy loads. Overloads can damage the winch and/or the wire rope and create unsafe operating conditions. For loads over 1,000 pounds we recommend the use of a pulley block to double line the wire rope. This reduces the load on the winch and the strain on the wire rope by approximately 50%. Attach hook to load bearing parts. The vehicle engine should be running during winch operation. If considerable winching is performed with the engine of, the battery may become too weak to re-start the engine.
2. After reading and understanding this manual, learn to use your winch. After installing the winch practice using it.
3. Do not move your vehicle to assist the winch in pulling the load. The combination of the winch and vehicle pulling together could overload the wire rope and winch.
4. Keep a safety distance. Ensure that all people stand well clear of winch during the operation. Always stand clear of wire rope, hook and winch. To avoid the unlikely event of component failure, it is best that you and other are out of harms way.
5. Inspect the wire rope and equipment frequently. A frayed wire rope with broken strands should be replaced immediately. Always replace wire rope with T-MAX's identical replacement part. Periodically check the winch installation to ensure that all bolts are tight.
6. Use leather gloves when handling the wire rope. Do not let the wire rope slide through your hands even when wearing gloves.
7. Never winch with less than 5 turns of wire rope or synthetic rope around

the winch drum since the wire rope end fastener will not withstand a load.

8. Always use the hand saver bar or hook strap (if so equipped) when guiding the wire rope in or out.

9. Keep clear of the winch, taut wire rope and hook when operating the winch. Never put your finger through the hook. If your finger should become trapped in the hook, you could lose your finger. Never hook the wire rope back onto itself because you could damage the wire rope. Use a nylon sling. (See Figure 5)



Figure 5

10. If a wire rope failure should occur, the cloth will act as a damper and help prevent the rope from whipping. (See Figure 6)

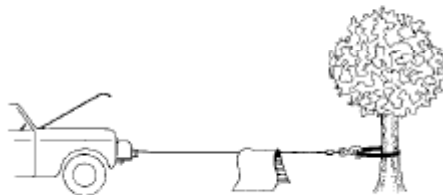

Figure 6

11. Your winch is not designed or intended for overhead hoisting operations. Never use your winch for lifting or moving people.

12. Avoid continuous pulls from extreme angles as this will cause the wire rope to pile up at one end of the drum. This can jamb the wire rope in the winch, causing damage to the winch or the wire rope.

13. Always operate the winch with an unobstructed view of the winching

operation. Equipment such as tackle, hooks, pulley blocks, straps, etc. should be sized to the winching task and should be periodically inspected for damage that could reduce their strength.

14. Take appropriate precautions to disable the winch when not in use or under supervision to prevent use by children or other unauthorized persons. Do not operate the winch when under the influence of drugs, alcohol or medication.

15. When moving a load, slowly take up the wire rope slack until it becomes taut. Stop, recheck all winching connections. Be sure the hook is properly seated. If a nylon sling is used, check the attachment to the load.

16. When using a winch to move a load, place the vehicle transmission in neutral, set the vehicle parking brake and chock the wheels.

17. Do not machine or weld any part of the winch. Such alterations may weaken the structural integrity of the winch.

18. Do not power the winch longer than 120 seconds. The drum and wire rope/synthetic rope may get too hot

19. Do not connect the winch to either 110C AC house current or 220V mains as winch burnout or fatal shock may occur. Never allow shock loads to be applied to the winch or wire rope.

20. Use caution when pulling or lowering a load up and down a ramp or incline. Keep people, pets and property clear of the path of the load.

INSTALLATION

MOUNTING YOUR WINCH

Please reading and understanding the following prescription:

Step (1)

Choose a mounting location that is sufficiently proper and safe to install your winch. Pay attention to the different brand and model of the vehicle, the mounting location may be also different. The safety mounting location must be plane and the thickness must be at least 0.31inch (8mm).

Do drill four holes which diameter is 10.5mm and position is 152mmX110mm. (see Figure 7)

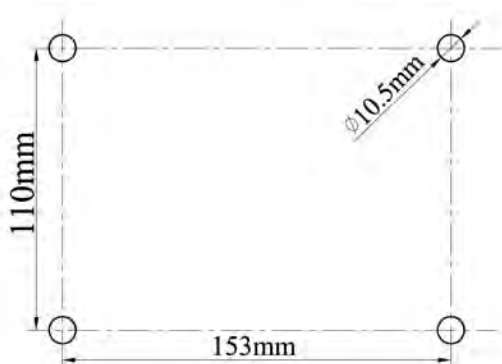

Figure 7

Step (2)

Open up the package, take out the winch and winch spare parts, then mount the winch as following figure. Let the mounting bolt through the holes (which is drilled in Step(1)) and the mounting plate from the bottom up.

Note: To use the mounting bolts (M10x35mm) and washer 0.4inch(10mm) which are supplied by T-MAX.

Step (3)

Turn the clutch handle to the direction of “out”;
 Let the wire rope through the roller fairlead;
 To connect the clevis hook on the wire rope;
 Turn the clutch handle as 90° reversely to the direction of “in” to engaged the clutch;

Note: To turn the drum slightly, the clutch is engaged if it could not be turned; or to repeat as “a” once more;

To fix the roller fairlead on the mounting plate.

Note: If the rope is synthetic rope, you can fix the aluminum fairlead on the mounting plate, and then reel the rope. Please see the method of how to do that as the attached interleaf.

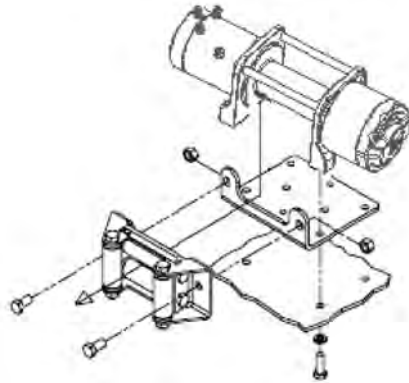

Installation Drawings

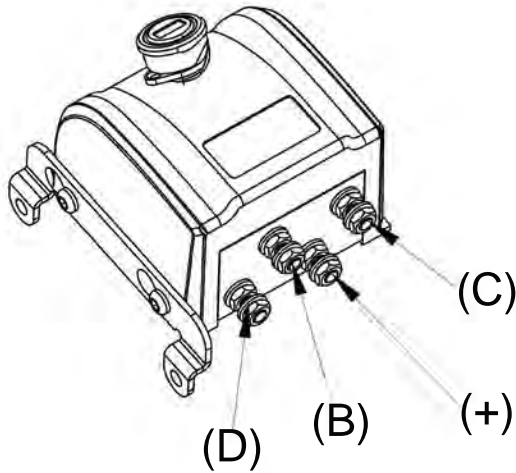

Control Box

Step(4) Mounting Control Box

Discharge two bolt which is at the side of the control box, and then to screw the two bolt through the hole of the mounting palte and fix the control box tightly with a wrench for Allen screws.

b. According to the above Figure of the Electric Theory, to connect the point “B”, “C” and “D”.

Step(5) Mounting the Control

Note: This Step is aim to who purchase the ATW6000 with control,

If you Purchase the ATW6000 with Remote Handle control ,overleap this step.

To install the Control (which is for ATV use) on the left handlebar;

To fasten the Control (which is for ATV use) after to readjust it on a suitable position;

Note:

- 1. The current is circulated when the vehicle works.**
- 2. Do wrap the cable with rubberized fabric to make sure all the wires is orderly.**

Step (6) Electrical Connection

Pay close attention to proper electrical cable connection as follows

Long Red Cable (length: 1.8m; square millimeter 25mm²), one terminal to the bottom terminal of the motor, and the other terminal connecting to positive (+) terminal of the battery the red terminal of the motor.

Long Black Cable (length: 1.8m; square millimeter 25mm²), one terminal to the bottom terminal (A) of the motor, and the other terminal connecting to negative (-) terminal of the battery the red terminal of the motor.

Note:

- 1. Be sure battery cables are not drawn taught across any surfaces, which could possible damage them.**
- 2. Be sure battery cables are not drawn taught across any surfaces, where is too hot or tight.**
- 3. Clean all connections especially in remote control switch and receptacle.**

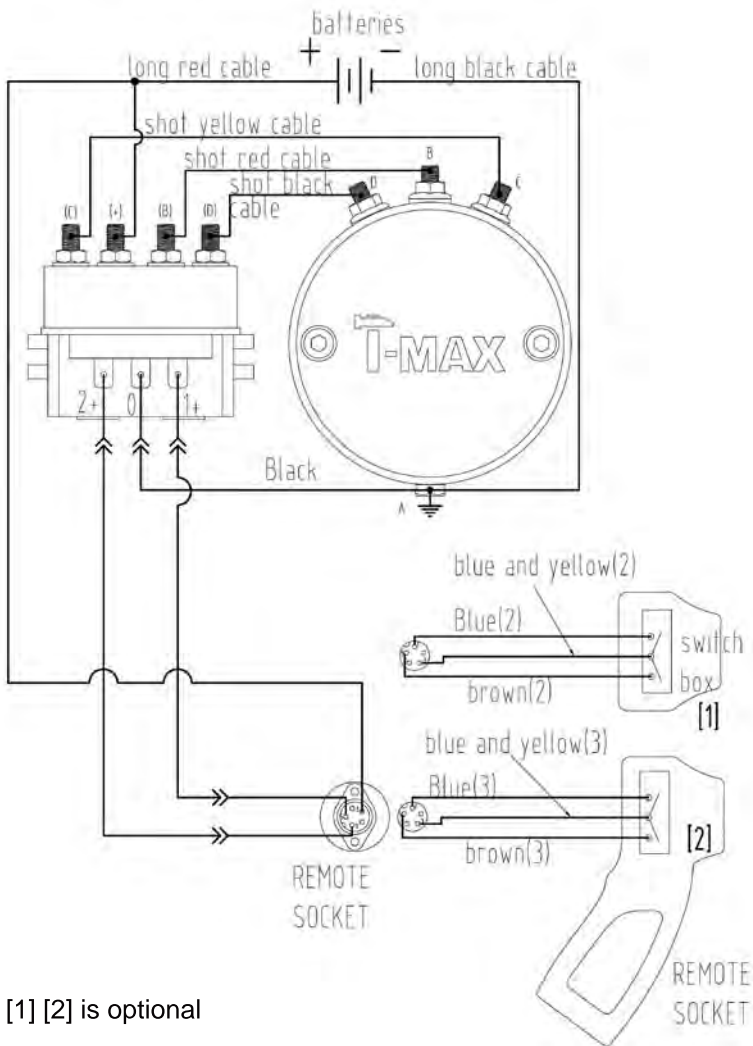

[1] [2] is optional

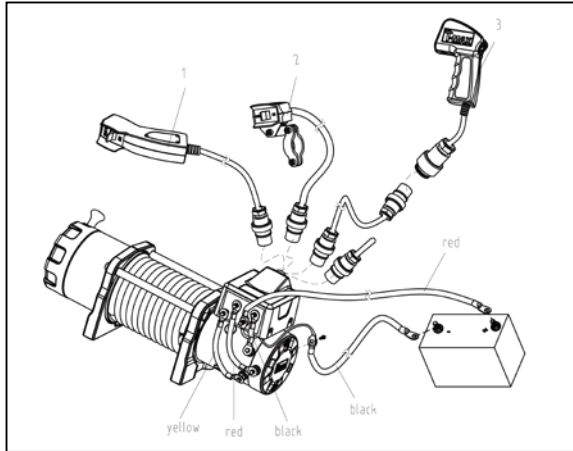

Battery Cable Wiring Diagram

Step (7) Check the Winch

Before to operate your winch, please check the following issues:

1. All connections of cables is correct;
2. No cable or tie-in is uncovered well;
3. All cables should be wrapped by Thermoplastics Pipes;
4. To disengage the clutch, turn on the remote control as “OUT” position. Cable may be free spooled off the drum;
5. To engage the clutch, turn on the remote control as “IN” position. The winch is now ready for pulling.

MAINTENANCE

Periodically check tightness of mounting bolts and electrical connections. Clear any dirt or corrosion that may have accumulated on the electrical connections.

NOTE:

Repair should be done by Authorize T-MAX Repair Centers ONLY. Do not attempt to disassemble the gear box. Disassembly will void warranty.

The safety precautions and instructions discussed in this manual can't cover all possible conditions and situations that may occur. It must be understood by the operator that common sense and caution are factors, which cannot be built into this product, but must be applied by the operator.

