



INSTALLATION INSTRUCTIONS
1994-98 Dodge Ram excl. Sport
1999-01 Dodge Ram 1500 All
1999-02 Dodge Ram 2500/3500 All
Part # 45-0600, 40-0605

PART LIST

1	Grille Guard
2	Frame Mount Bracket, Passenger and Driver
2	Top Bracket, Passenger and Driver
2	Mount Tab, Diesel Application Only
2	Mount Clamp, Diesel Application Only
4	M10*25 Hex Head Bolt, Stainless Steel
6	M10*40 Hex Head Bolt, Stainless Steel
18	M10 Flat Washer, Stainless Steel
8	M10 Lock Washer, Stainless Steel
10	M10 Hex Nut, Stainless Steel

Note: Westin Automotive advises the installer to use a thread lubricant on all of the stainless steel fasteners.

PROCEDURE

1. Remove the contents from box and check for damage. Verify all parts are present. Read instructions completely before beginning.
Note: Some fasteners and brackets will be left over after installation
2. Remove factory tow hooks, if equipped, from front of truck. Remove factory plastic spoiler or cut a space in the plastic spoiler to allow for the bottom of the Grille Guard uprights to slide through and eventually attach to the Frame Mount Brackets.
Note: If vehicle is not equipped with tow hooks, locate (2) bolts on each side of truck that would secure them.
3. Attach passenger-side Frame Mount Bracket to the frame rail using the tow hook bolts that were just removed (see Figure 1), Hand tighten.
4. Repeat for driver-side of vehicle.
5. Skip this step on diesel models; with the hood open, remove the 8mm bolts from the A/C condenser support bracket. (see Figure 2). Install top brackets as shown, Hand tighten.

6. Place Sportsman assembly face down under front of vehicle. Line up rear slot in mount bracket with the rear most slot in the Grille Guard assembly. Attach using the long M10 Hex Bolts, Flat Washers, Lock Washers, and Hex Nuts as shown, Hand tighten.
7. Rotate Grille Guard assembly up until remaining slots are aligned. Secure with M10 fasteners in remaining holes, Hand tighten. Note: Diesel model owners proceed to step 10.
8. Attach top bracket to the Grille Guard assembly using the short M10 Hex Bolts, Flat Washers, Lock Washers, and Hex Nuts as shown, Hand tighten.
9. Center and level Grille Guard with vehicle. Tighten all fasteners.
10. Secure top of Grille Guard assembly as shown (see Figure 3). Start the mount clamp bolt on both sides and then draw unit in towards vehicle until it feels secure. Tighten nut against top clamp to secure.
11. Level and adjust Grille Guard. Tighten all fasteners.

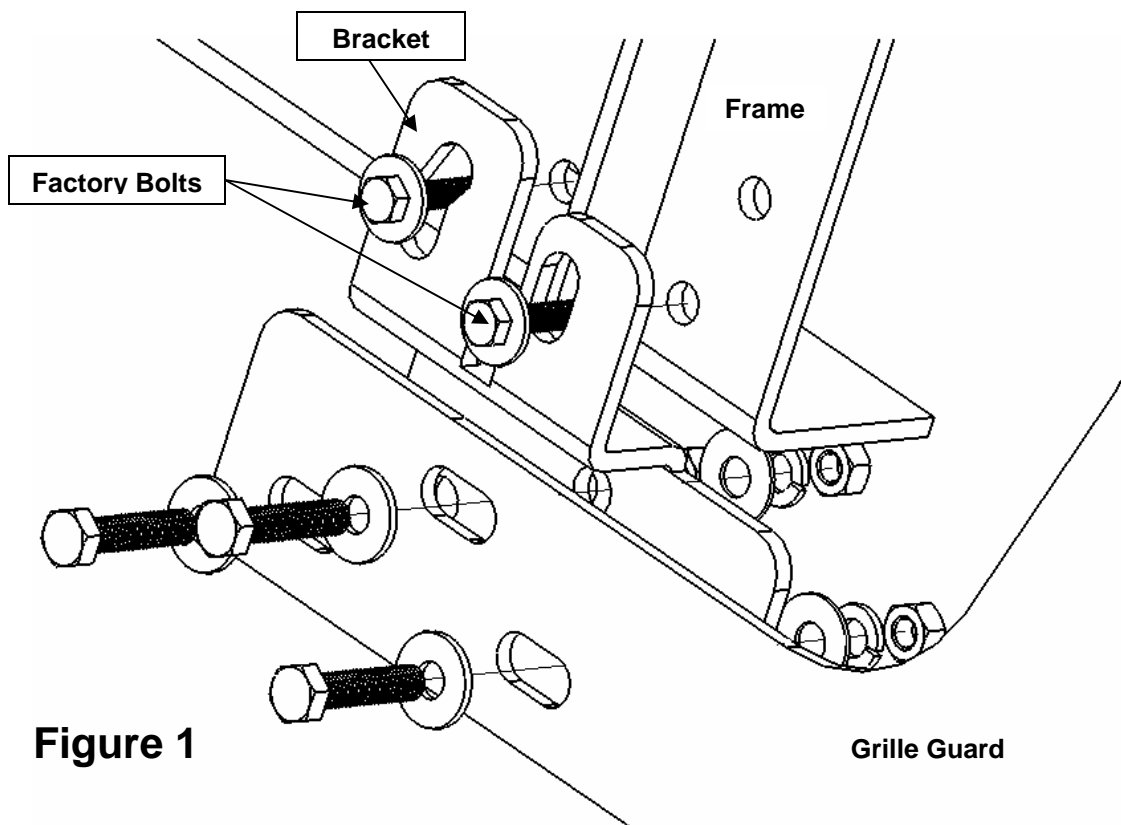

Passenger Side Shown

Revision A 12/10/07

Figure 2

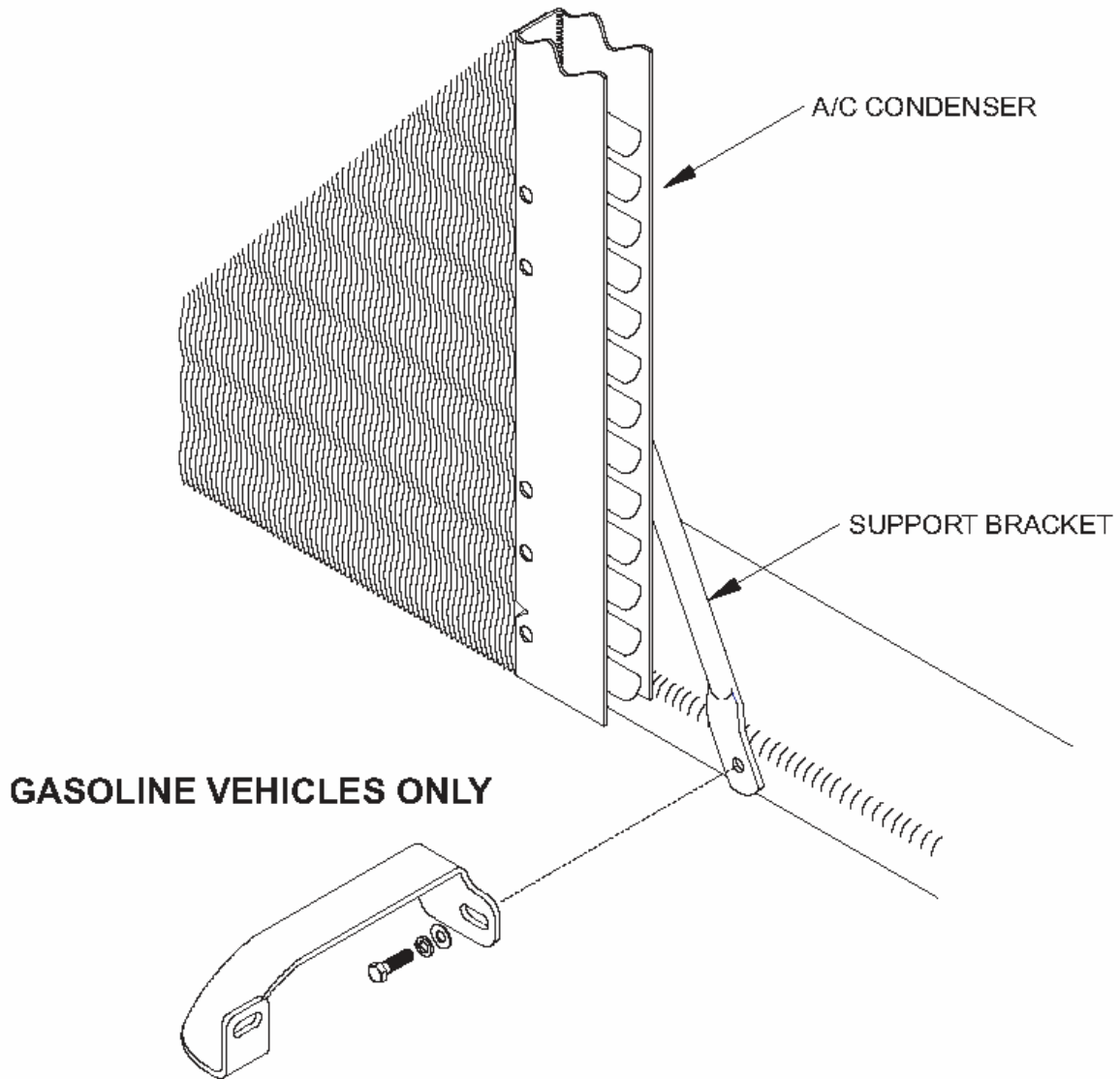

Driver Side Shown

Revision A 12/10/07

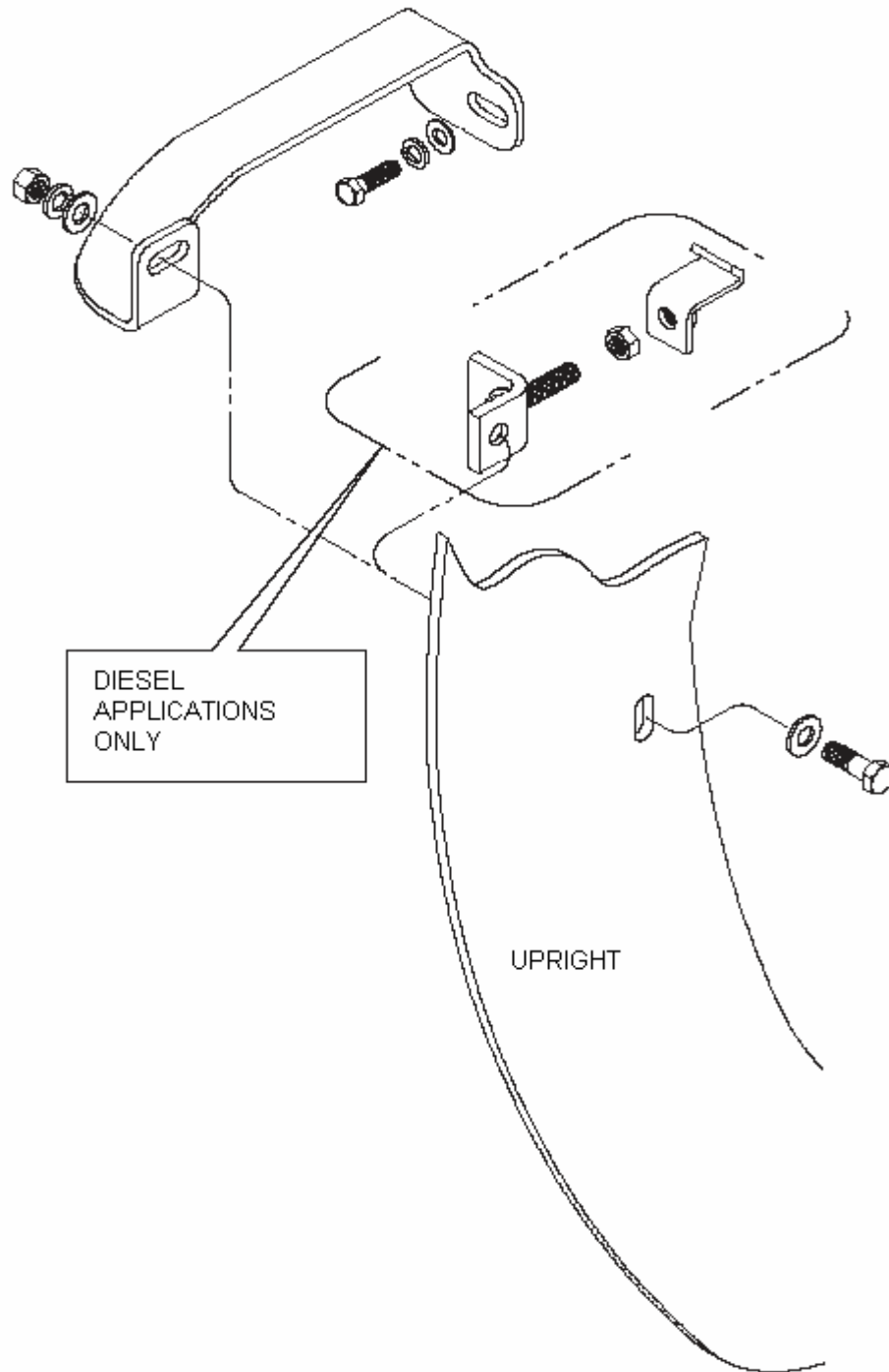

Figure 3

Driver Side Shown



Westin Automotive Products, Inc.
5200 N. Irwindale Ave. Suite 220
Irwindale, Ca. 91706

Thank You for choosing Westin products
For additional installation assistance please call
Customer service (800) 793-7846 or (507) 375-3559

Revision A 12/10/07