



**INSTALLATION INSTRUCTIONS**  
**2006-08 Hummer H3**  
**Part # 45-1920, 40-1925**

**PARTS LIST:**

1	Grille Guard
2	Top Support Brace (Driver and Passenger)
2	M8 Button Head Bolt, Stainless Steel
4	M8 Flat Washer, Stainless Steel
2	M8 Lock Washer, Stainless Steel
2	M8 Hex Nut, Stainless Steel

**Note:** Westin advises the installer to use a thread lubricant on all stainless hardware.

**IMPORTANT:** Carefully read this information before attempting to install this product. The manufacturer is in no way responsible for any damage to the vehicle or personal injury that may occur during the installation or use of this product. **NO DRILLING REQUIRED.**

**PROCEDURE:**

**Step 1:** Remove the contents from box and verify all parts are present. Read instructions completely before beginning.

**Step 2:** Remove the tow hook loops from the front of the vehicle using a 24mm socket and 24mm wrench, remove the brackets using an 18mm socket, 18mm wrench, and T-30 Torx driver. (Figure 1)

**Step 3:** Install the Grille Guard behind the loop mount brackets using the factory bolts.

**Step 4:** Remove two bolts from the grille as shown in Figure 2.

**Step 5:** Install Upper braces on the Grille Guard using the M8 hardware, reinstall the bolts removed from the grille. (Figure 3 & 4)

**Step 6:** Level and adjust Grille Guard, tighten all bolts, and reinstall tow hook loops.

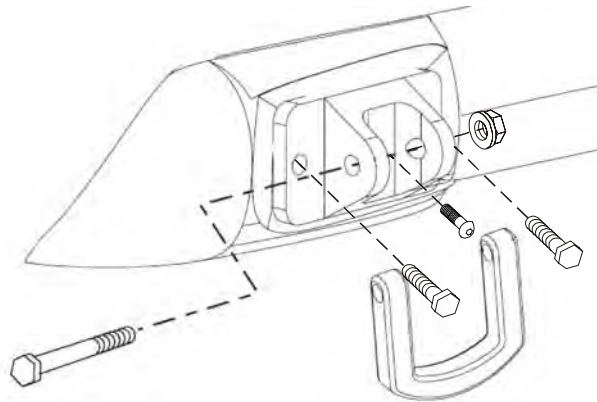
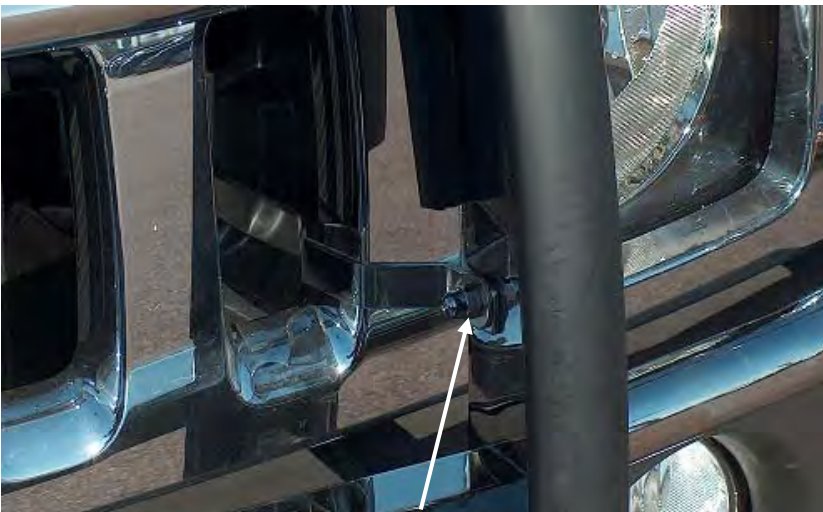

**Figure 1** Removing Tow Hook Loop and Bracket

**Figure 2**



Remove Bolts from  
Grille



M8 Hardware

**Figure 3**  
Driver Side Shown

Factory Bolt  
in Grille

**Figure 4**



Westin Automotive Products, Inc.  
5200 N. Irwindale Ave. Suite 220  
Irwindale, Ca. 91706

Thank You for choosing Westin products  
For additional installation assistance please call  
Customer service (800) 793-7846 or (507) 375-3559

Revision A 11/20/07