



40905  
01/08/10  
REV-2

INSTALLATION INSTRUCTIONS FOR  
**4 Door Chevy Tahoe and GMC Yukon,  
40905 (Set)**

"OE" style flares

**TOOLS REQUIRED FOR INSTALLATION:**

- Electric Drill
- #2 Phillips Bit
- 3/16" & 11/32" Drill Bits
- Fine Grit Sandpaper

**IMPORTANT: READ BEFORE BEGINNING INSTALLATION**

**Verifying Fit** - Flares should be held to the vehicle surface to verify correct type and fit BEFORE beginning installation or painting. Small fit adjustments can be made by trimming (filing, sanding or scraping) excess plastic.

**Painting** - Sand (optional) before application of paint. Clean outer surface with a good grade degreaser. **Do not use** lacquer thinner or enamel reducer as a degreaser. Wipe outer surface thoroughly with a tack rag prior to painting. Paint flares using a high quality lacquer, enamel, or polyurethane automotive paint. Application of a primer coat is optional. It is recommended that painting (when desired) be done prior to installation.

**Performance** - Using larger tires may increase the area required to turn the vehicle. Some Tire/Rim combinations may require lowering bump stops and/or installing steering stops to prevent tire shoulders from contacting flare.

**Exhaust System** - Modifications may be necessary to maintain a minimum 4-inch clearance between flares and exhaust pipes. Exhaust gases should not vent directly onto flares.

**DO NOT USE:** Loctite, SuperGlue, or similar products on the hardware or the flares.

---

**FLARE INSTALLATION PROCEDURES**

**Step 1: Preparing the Work Area (Front and Rear)**

- Remove factory flare, bumper fender extension, and wheel well trim within 4" of the rim, if any.
- Remove wheel and support vehicle using jack and jack stands should additional space be required.

**Step 2: Fitting Flare to Body Side Molding**

- On vehicles with hard rubber body side moldings, it will be necessary to trim moldings.
- Place flare into wheel well opening and mark a line where flare intersects molding.
- Using a wide putty knife, separate molding from body as far as 2"-3" beyond line marked.
- Protect vehicle surface with many layers of duct tape and cut molding 1/4" out from marked line. (Strong scissors are recommended for cleanest cut.)

**Step 3: Flare Installation (Front)**

- Pre-drill the Front Parts with a 3/16" drill bit using the indents formed into the parts as a guide
- Attach edge trim to exterior of each front flare as shown in illustration #1.
- Hold flare in place on fender.
- Applying pressure to the outside surface of the flare, fasten the flare to the vehicle with kit supplied drill tip screws.

**Step 4:**

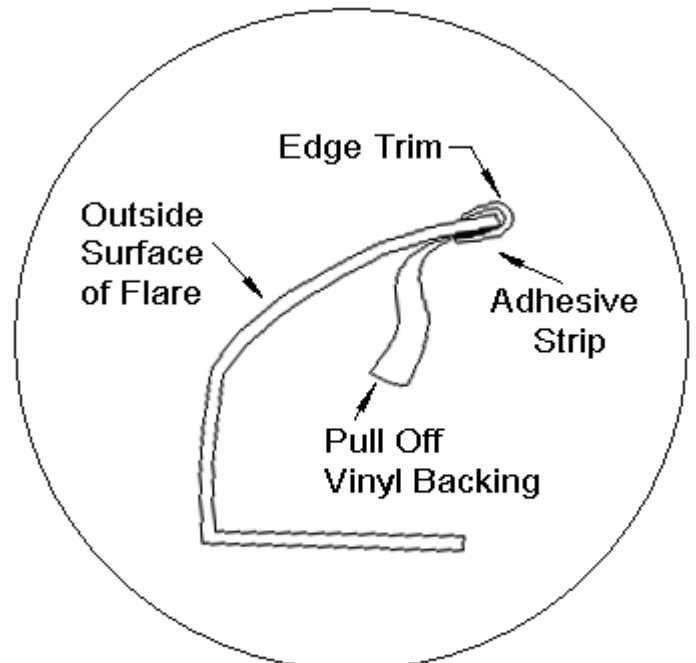

**Illustration #1**

## Flare Installation (Rear)

There are two parts to each rear flare: the Door Piece, and the Rear Part. Special attention must be given to assure proper alignment of these parts to each other.

### (A) Rear Part Installation:

1. Pre-drill the Rear Parts with a 3/16" drill bit using the indents formed into the parts as a guide.
2. Attach edge trim to the exterior edge of the Rear Part as shown in illustration #1.
3. Align the front edge of the Rear Part to door seam, apply pressure and secure it to the fender using drill tip screws.

### (B) Door Piece Installation:

1. With the door closed, apply a strip of double sided tape to the outside of the door along the door seam, and peel the red vinyl backing away from the tape. See illustration#3.
2. Aligning the Door Piece with the edge of the door and the Rear Part, place the Door Piece on the door and press firmly into position over the double stick tape.
3. While holding Door Piece in position, open the door and adhere the supplied Mylar tabs to the door lip covering the slots in the door piece. See illustration# 3.
4. Install the supplied clips by pushing the long side of the clip into slot of the flare, while also tucking the Mylar tab into the slot and the edge of the door. See illustration #4. (Adjust if necessary).

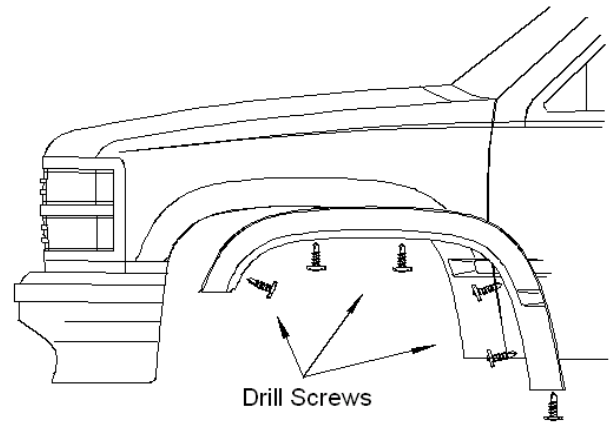

ILLUSTRATION #2

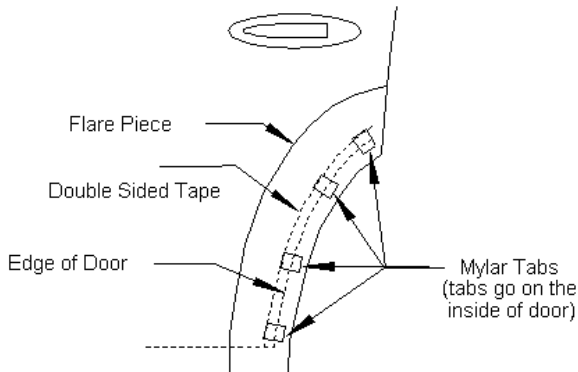

ILLUSTRATION #3

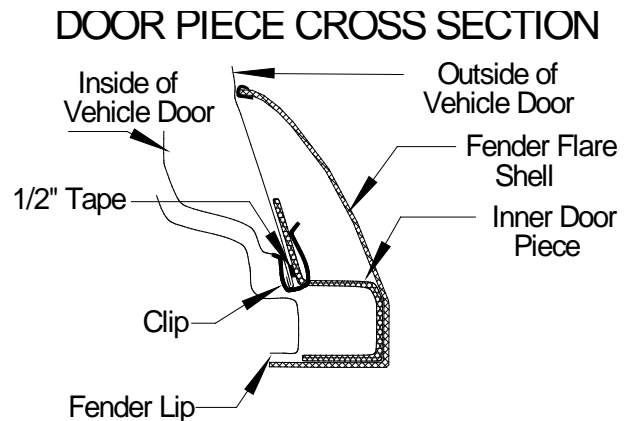

ILLUSTRATION #4