



INTAKE SYSTEM

INSTALLATION INSTRUCTIONS

21-802C

AUDI

2015-20 A3

2017-20 S3

2018-22 Q3

L4-2.0T

VOLKSWAGEN

2016-22 GTI / GOLF R

2019-22 ARTEON

2019-25 JETTA GLI

L4-2.0T

2017-19 GOLF

L4-1.8T

NOT LEGAL FOR SALE OR USE ON ANY POLLUTION CONTROLLED MOTOR VEHICLE IN CALIFORNIA OR STATES ADOPTING CALIFORNIA EMISSION PROCEDURES.

See aemintakes.com for CARB status on each part for a specific vehicle

TOOLS NEEDED:

Screwdriver
7mm Socket
10mm Socket
Socket Driver
Small Torque
Wrench

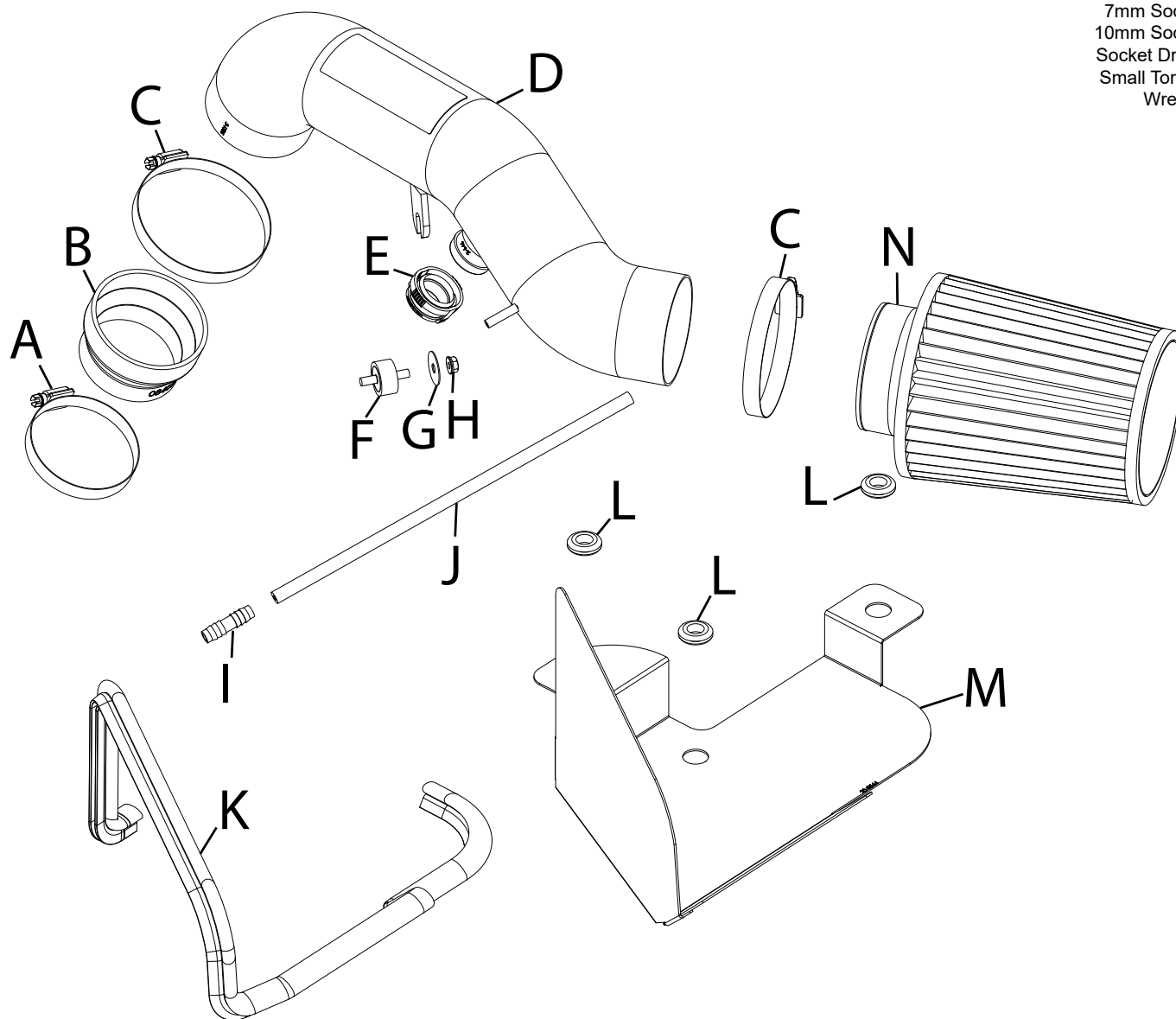

PARTS LIST:

Description	Qty.	Part #	Description	Qty.	Part #	Description	Qty.	Part #
A HOSE CLAMP; 2.31"-3.25"	1	9444	F STUD; M6-1.00 RUBBER	1	07027	K EDGE TRIM; (35"L)	1	102471
B HOSE; 3.25" TO 2.75"ID X 2"L	1	084034	G WASHER; 1"D X 1/4" HOLE	1	08160	L GROMMET; 1/2"ID, 3/32"GW	3	784646
C CLAMP; 1/2" BNDHOSE	2	9456	H NUT; M6, HEX, SERRATED	1	444.460.04	M HEAT SHIELD	1	20-8544
D INTAKE TUBE; 3.25"OD X 19"	1	2-1585C	I VENT; 1/4" HOSE	1	08042	N AIR FILTER	1	21-2113D
E CAP; PUSH FIT PLUG	1	8-215	J HOSE; 4MM ID X 12"L	1	08147			

If you need any assistance please call 1-800-858-3333 to speak with a representative in our Customer Service Center before returning the product.

Read and understand these instructions **BEFORE** attempting to install this product. Failure to follow installation instructions and not using the provided hardware may damage the intake tube, throttle body and engine.

TO START:

1. Turn off the ignition and disconnect the negative battery cable.

NOTE: Disconnecting the negative battery cable erases pre-programmed electronic memories. Write down all memory settings before disconnecting the negative battery cable. Some radios will require an anti-theft code to be entered after the battery is reconnected. The anti-theft code is typically supplied with your owner's manual. In the event your vehicles anti-theft code cannot be recovered, contact an authorized dealership to obtain your vehicles anti-theft code.



2. Remove the plastic engine cover by pulling up gently, releasing it from the rubber grommets.



3. Loosen the hose clamp at the turbocharger and disengage the intake hose from the turbo inlet.



4. Remove small vacuum line from the stock air box. Remove the large air injection hose by depressing the rubber parts of the collar. **Note: Not all models will have this large hose.**



5. Remove the stock air box and intake hose assembly from the vehicle by pulling upwards to disengage the three rubber grommets. Lift the hose side first and maneuver the box towards the rear, clearing the cold air inlet.



6. Install the provided edge trim and rubber grommets onto the AEM heat shield as shown.



7. Install the provided coupler and hose clamps onto the turbo with the small end towards the turbo inlet. Tighten the turbo-side hose clamp to 30in-lb.



8. Install the provided rubber mount onto the side of the engine. Loosely install the provided washer and nut onto the tuber mount.



9. Install the AEM heat shield onto the factory air box mounting studs. Soapy water may be used to help the grommets engage with the studs.



10. Position the AEM intake tube in the engine bay and connect the small vacuum hose to the small nipple. Move the large air injection hose behind the AEM heat shield and connect it to the AEM intake tube. Soapy water should be used to help installation. **Note: Not all models have this large hose. Install the included blind plug (8-215) in its place. On vehicles that the factory vacuum line is too short, use the provided union and vacuum line to complete the connection.**



11. Lower the AEM intake tube bracket onto the rubber mount, between the washer and rubber mount, and insert the tube into the coupler. Do not tighten the mount or coupler at this time.



Reassemble Vehicle

Position the inlet pipes for the best fitment. Be sure that the pipes or any other components do not contact any part of the vehicle. Tighten the rubber mount, all bolts, and hose clamps. Check for proper hood clearance. Re-adjust pipes if necessary and re-tighten them. Inspect the engine bay for any loose tools and check that all fasteners that were moved or removed are properly tightened. Reconnect negative battery terminal and start engine. Let the vehicle idle for 3 minutes. Perform a final inspection before driving the vehicle.

Service and Maintenance

AEM Induction Systems requires cleaning the intake system's air filter element every 100,000 miles. When used in dusty or off-road environments, our filters will require cleaning more often. We recommend that you visually inspect your filter once every 25,000 miles to determine if the screen is still visible. When the screen is no longer visible some place on the filter element, it is time to clean it. To clean, purchase our Synthetic air filter cleaner, part number AEM-1-1000 and follow the easy instructions. Use window cleaner to clean your powder coated AEM® intake tube.

NOTE: DO NOT USE aluminum polish on powder coated AEM® intake tubes.

NOT LEGAL FOR SALE OR USE ON ANY POLLUTION CONTROLLED MOTOR VEHICLE IN CALIFORNIA OR STATES ADOPTING CALIFORNIA EMISSION PROCEDURES.

See aemintakes.com for CARB status on each part for a specific vehicle

AEM Air Intake System Warranty Policy

AEM® warrants that its intake systems will last for the life of your vehicle. AEM will not honor this warranty due to mechanical damage (i.e. improper installation or fitment), damage from misuse, accidents or flying debris. AEM will not warrant its powder coating if the finish has been cleaned with a hydrocarbon-based solvent. The powder coating should only be cleaned with a mild soap and water solution. Proof of purchase of both the vehicle and AEM intake system is required for redemption of a warranty claim.

This warranty is limited to the repair or replacement of the AEM part. In no event shall this warranty exceed the original purchase price of the AEM part nor shall AEM be responsible for special, incidental or consequential damages or cost incurred due to the failure of this product. Warranty claims to AEM must be transportation prepaid and accompanied with dated proof of purchase. This warranty applies only to the original purchaser of product and is nontransferable. Improper use or installation, use for racing, accident, abuse, unauthorized repairs or alterations voids this warranty. AEM disclaims any liability for consequential damages due to breach of any written or implied warranty on all products manufactured by AEM. Warranty returns will only be accepted by AEM when accompanied by a valid Return Merchandise Authorization (RMA) number. Credit for defective products will be issued pending inspection. Product must be received by AEM within 30 days of the date RMA is issued.

If you have a warranty issue, please call (800) 992-3000 and our customer service department will assist you. A proof of purchase is required for all AEM warranty claims.