

AirCELL

by AIR LIFT®

Kit 52210

Toyota Tundra

Rear application



INSTALLATION GUIDE

For maximum effectiveness and safety, please read these instructions completely before proceeding with installation.

Failure to read these instructions can result in an incorrect installation.

Installation Diagram

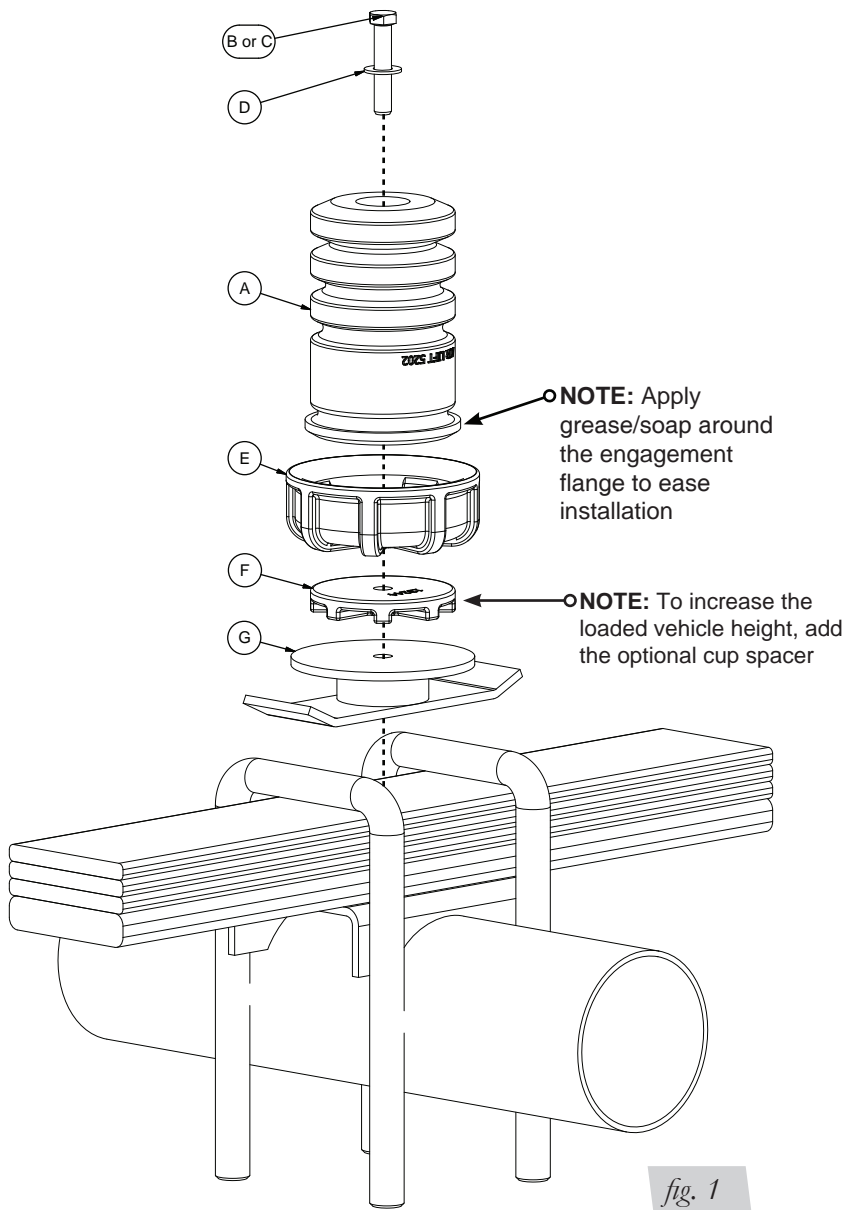

fig. 1

Important Safety Notice

The installation of this kit does not alter the Gross Vehicle Weight Rating (GVWR) or payload of the vehicle. Check your vehicle's owner's manual and do not exceed the maximum load listed for your vehicle.

Gross Vehicle Weight Rating: The maximum allowable weight of the fully loaded vehicle (including passengers and cargo). This number — along with other weight limits, as well as tire, rim size and inflation pressure data — is shown on the vehicle's Safety Compliance Certification Label.

Payload: The combined, maximum allowable weight of cargo and passengers that the truck is designed to carry. Payload is GVWR minus the Base Curb Weight.

HARDWARE LIST

Item	Part #	Description.....Qty
A	52022	Spring.....2
B	17108	3/8"-16X1.5 Bolt.....2
C	17169	3/8"-16X2 Bolt.....2
D	18444	3/8" Flat Washer.....2
E	10911	Spring Cup.....2
F	13244	Cup Spacer.....2
G	03114	Bracket.....2

TOOLS LIST

Description.....	Qty
Hoist or Floor Jack.....	1
Safety Stands.....	2
Metric and standard sockets.....	1
Metric and standard wrenches.....	1
Ratchet.....	1



Missing or damaged parts? Call Air Lift customer service at (800) 248-0892 for a replacement part.

Installing the AirCell System

ASSEMBLING AND ATTACHING THE SYSTEM

1. Jack up the rear of the vehicle or raise on a hoist. Support the differential (axle) with safety stands. Remove the wheels.

NOTE

Keep the axle supported during this assembly process.

2. Loosen the axle/leaf spring u-bolts enough to remove the existing jounce bumper assembly on both sides.
3. Assemble the spring cup to the bracket using 3/8 bolt and flat washer (fig 1). Torque the hardware to 31ft/lbs.
4. Attach the bracket/spring cup assembly to the vehicle under the stock u-bolts that were previously loosened. Center the bracket/spring cup assembly above the axle (fig 1). Raise the axle and torque the u-bolts to the OEM specifications.
5. Insert the spring into the cup. A twisting motion while pushing the spring into the cup will make the installation quicker. Make sure the spring snaps into position into the cup.

NOTE

It may be necessary to drop the axle slightly to gain access.

Applying grease or soap around the engagement flange of the spring (A) will help in aiding the spring (A) to “snap” into the spring cup (E).

OPTIONAL

You can adjust the loaded height of the vehicle by adding the optional cup spacer between the cup and the bracket. It will be necessary to use the longer hardware provided to install the cup spacer (see fig 1 note).

Warranty and Returns Policy

Air Lift Company warrants its products, for the time periods listed below, to the original retail purchaser against manufacturing defects when used on catalog-listed applications on cars, vans, light trucks and motorhomes under normal operating conditions for as long as Air Lift manufactures the product. The warranty does not apply to products that have been improperly applied, improperly installed, used in racing or off-road applications, used for commercial purposes, or which have not been maintained in accordance with installation instructions furnished with all products. The consumer will be responsible for removing (labor charges) the defective product from the vehicle and returning it, transportation costs prepaid, to the dealer from which it was purchased or to Air Lift Company for verification.

Air Lift will repair or replace, at its option, defective products or components. A minimum \$10.00 shipping and handling charge will apply to all warranty claims. Before returning any defective product, you must call Air Lift at (800) 248-0892 in the U.S. and Canada (elsewhere, (517) 322-2144) for a Returned Materials Authorization (RMA) number. Returns to Air Lift can be sent to: Air Lift Company • 2727 Snow Road • Lansing, MI • 48917.

Product failures resulting from abnormal use or misuse are excluded from this warranty. The loss of use of the product, loss of time, inconvenience, commercial loss or consequential damages is not covered. The consumer is responsible for installation/reinstallation (labor charges) of the product. Air Lift Company reserves the right to change the design of any product without assuming any obligation to modify any product previously manufactured.

This warranty gives you specific legal rights and you may also have other rights that vary from state-to-state. Some states do not allow limitations on how long an implied warranty lasts or allow the exclusion or limitation of incidental or consequential damages. The above limitation or exclusion may not apply to you. There are no warranties, expressed or implied including any implied warranties of merchantability and fitness, which extend beyond this warranty period. There are no warranties that extend beyond the description on the face hereof. Seller disclaims the implied warranty of merchantability. (Dated proof of purchase required.)

AirCell	Lifetime Limited	Load Controller (I)	2 Year Limited
Air Lift 1000	Lifetime Limited	Load Controller (II)	2 Year Limited
RideControl	Lifetime Limited	SmartAir	2 Year Limited
SlamAir	Lifetime Limited	Wireless AIR	2 Year Limited
LoadLifter 5000*	Lifetime Limited	Other Accessories	2 Year Limited
EasyStreet Systems	1 Year Limited		<i>*formerly SuperDuty</i>

Replacement Information

If you need replacement parts, contact the local dealer or call Air Lift customer service at (800) 248-0892. Most parts are immediately available and can be shipped the same day.

Contact Air Lift Company customer service at (800) 248-0892, first if:

- Parts are missing from the kit.
- Need technical assistance on installation or operation.
- Broken or defective parts in the kit.
- Wrong parts in the kit.
- Have a warranty claim or question.

Contact the retailer where the kit was purchased:

- If it is necessary to return or exchange the kit for any reason.
- If there is a problem with shipping if shipped from the retailer.
- If there is a problem with the price.

Need Help?

Contact our customer service department by calling (800) 248-0892, Monday through Friday, 8 a.m. to 5 p.m. Eastern Time. For calls from outside the USA or Canada, our local number is (517) 322-2144.

**Register your warranty online at
www.airliftcompany.com/warranty**



Thank you for purchasing Air Lift products — the professional installer's choice!

Air Lift Company • 2727 Snow Road • Lansing, MI 48917 or PO Box 80167 • Lansing, MI 48908-0167
Toll Free (800) 248-0892 • Local (517) 322-2144 • Fax (517) 322-0240 • www.airliftcompany.com

Printed in
the USA