

Airaid

Installation Instructions

For Part Numbers:

200-335 720-243 Airaid Oiled Media Filter

201-335 721-243 SynthaMax Dry Media Filter - Red

2017-19 CHEVROLET Silverado

2017-19 GMC Sierra

V8-6.6L Turbo Diesel

INTAKE SYSTEMS FOR VEHICLES LISTED ARE 50 STATE LEGAL. SEE AIRAID.COM FOR CARB STATUS ON EACH PART FOR A SPECIFIC VEHICLE.

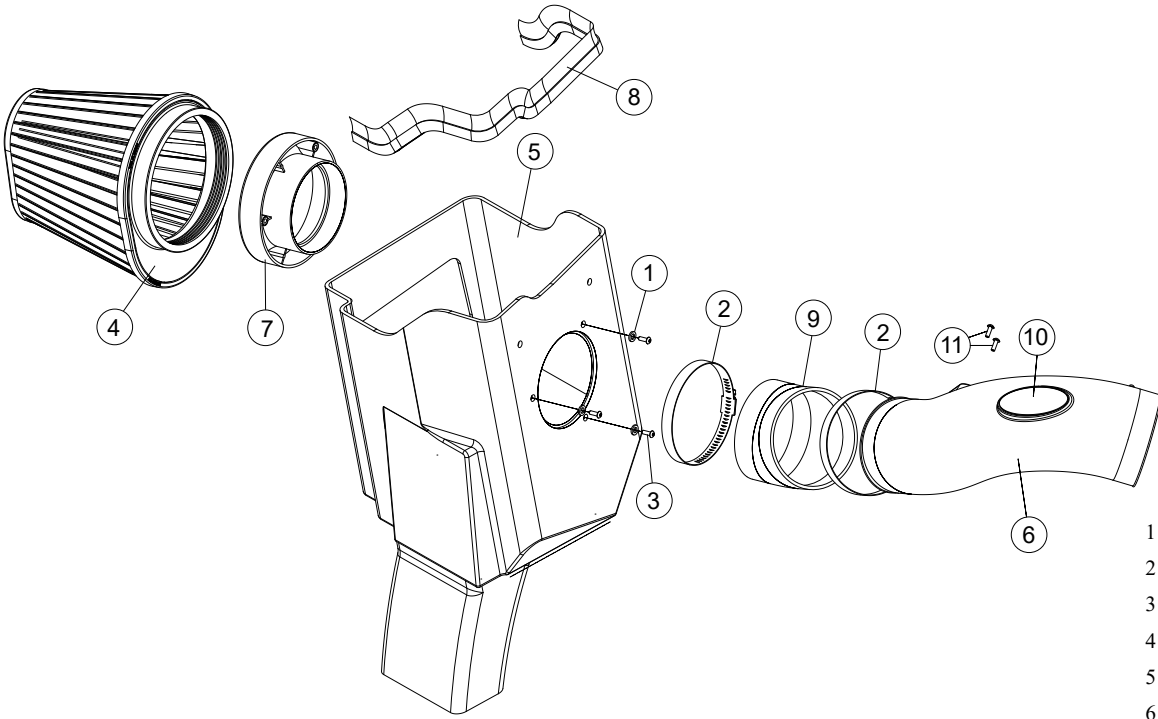

Component Identification

1	08275	WASHER; FLAT ZINC 3/16 #10	3
2	08671	HOSE CLAMP #72	2
3	KIT15DHC3050	SCREW; BUTTON HEAD SOCKET CAP 1/4"	3
4	720/721-243	AIRAID FILTER	1
5	KIT335CAB	AIR BOX	1
6	KIT335	INTAKE TUBE	1
7	KIT1121MAFADA	ADAPTER; MAF PLASTIC 112-1	1
8	KITWSTRIP18	EDGE TRIM (24")	1
9	KITELBOW4325	ELBOW; 4.325"ID - 25 DEGREE ANGLE	1
10	KITSTICKER12	STICKER, AIRAID	1
11	KIT15BHC3050	SCREW; BUTTON HEAD SOCKET CAP 8-32	2

Full color instructions can be viewed on our web site at Airaid.com.

If you need any assistance please call 1-800-498-6951 to speak with a representative in our Customer Service Center before returning the product.

TO START:

1. Turn off the ignition and disconnect the negative battery cable.

NOTE: Disconnecting the negative battery cable erases pre-programmed electronic memories. Write down all memory settings before disconnecting the negative battery cable. Some radios will require an anti-theft code to be entered after the battery is reconnected. The anti-theft code is typically supplied with your owner's manual. In the event your vehicles anti-theft code cannot be recovered, contact an authorized dealership to obtain your vehicles anti-theft code.



2. Loosen the hose clamps that secure intake tube to the turbo inlet and air filter housing, then remove the intake tube from the vehicle.



3. Release the red locking tab and then disconnect the mass air sensor electrical connection. Unhook the coolant bypass hose from the air box. Lift the factory air filter housing up to dislodge it from the mounting grommets and then remove the housing from the vehicle.

NOTE: AIRAID recommends that customers do not discard factory air intake.



4. Remove the four bolts that secure the air filter mounting flange to the inner fender and then remove the mounting flange from the vehicle.

NOTE: three of the four factory bolts will be reused in a later step.



5. Install the provided air filter adapter into the AIRAID® Cold Air Box and secure with the hardware provided.

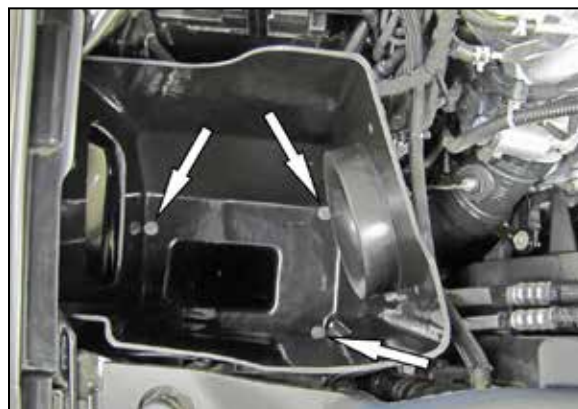

6. Install the AIRAID® Cold Air Box into the vehicle and secure to the air filter mounting plate location and secure with three of the factory bolts from step #4.



7. Install the elbow coupler hose clamps onto the filter adapter as shown but do not tighten at this time.



8. Remove the mass air sensor from the factory air filter housing as shown.



9. Install the mass air sensor into the AIRAID® intake tube and secure with the provided hardware. Install the AIRAID® decal to the tube.

Continued...



10. Install the AIRAID® intake tube into the elbow coupler and then into the factory plenum, adjust the elbow coupler and intake tube for best fit and then secure with the provided hose clamps.



11. Reconnect the mass air sensor electrical connection, clip the coolant bypass hose to the AIRAID® Cold Air Box using the factory retaining clip.



12. Using care so as not to damage the air filter, Install the AIRAID® air filter into the air box and onto the filter adapter, then secure with the provided hardware.



13. Install the weather strip onto the edge of the Cold Air Box so the contour rolls away from the air filter. **NOTE: Some trimming of the weather strip will be necessary. Install with lip rolling away from the filter.**



14. Double check your work!

Make sure there is no foreign material in the intake path. Make sure all clamps, hoses, bolts, and screws are tight. Double check the hood clearance!

Reconnect the negative battery cable!

15. **NOTE:** Most General Motors vehicles have the Vehicle Emissions Certification Information (VECI) label affixed to the air filter box. In order to be compliant with California emissions laws, the label **MUST** remain in the engine compartment. If the Vehicle Emission Control Information label is removed during modification, a new replacement label must be obtained and installed in a readily visible position in the engine compartment. The label shall not be affixed to any equipment which is easily detached from the vehicle. We recommend that the label is affixed to the underside of the hood adjacent to the hood latch. The label is Vehicle Identification Number dependent and can be ordered from the vehicle dealership. In order to receive the proper decal please bring your VIN with you. Failure to have the VECI under the hood may result in failure of a pre-registration smog test.

Thank you for purchasing the Airaid Intake System. Contact Airaid @ (800) 498-6951 8:00 AM - 5:00 PM MST weekdays for questions regarding fit or instructions that are not clear to you. Your Airaid Intake System was carefully inspected and packaged. Check that no parts are missing, or were damaged during shipping. If any parts are missing, contact Airaid. The air filter element is protected from direct exposure to water and debris; care should be taken not to drive through deep water.

WATER INGESTION IS THE DRIVERS RESPONSIBILITY! The air filter is reusable and should be cleaned periodically.

For your Oiled media filter we offer the Airaid Tune Up Kit!



P/N 790-551 Aerosol Spray
P/N 790-550 Squeeze Spray



INTAKE SYSTEMS FOR VEHICLES LISTED ARE 50 STATE LEGAL. SEE AIRAID.COM FOR CARB STATUS ON EACH PART FOR A SPECIFIC VEHICLE.

SynthaMax®

Do Not Oil

Synthamax Air Filters do not require oil. Service air filter as needed by cleaning with common non-petroleum all-purpose household cleaner and water. Simple Green®, Formula 409® or equivalent works great. Apply cleaner to outside of air filter and allow to soak. Then flush filter clean from the inside out with a garden hose and repeat steps if necessary. Do not apply high pressure water or air to clean filter. Allow filter to air dry and reinstall.