

Airaid

INSTALLATION INSTRUCTIONS

200-382 700-469 Airaid Oiled Media Filter

201-382 701-469 SynthaMax Dry Media Filter

2019-21 CHEVROLET Silverado 1500 / Sierra 1500

2019-21 Tahoe / Suburban

2019-21 Yukon / Yukon XL

2021 Cadillac Escalade / Escalade ESV

V8-5.3L / 6.2L

NOT LEGAL FOR SALE OR USE ON ANY POLLUTION CONTROLLED MOTOR VEHICLE IN CALIFORNIA OR STATES ADOPTING CALIFORNIA EMISSION PROCEDURES.

See Airaid.com for CARB status on each part for a specific vehicle

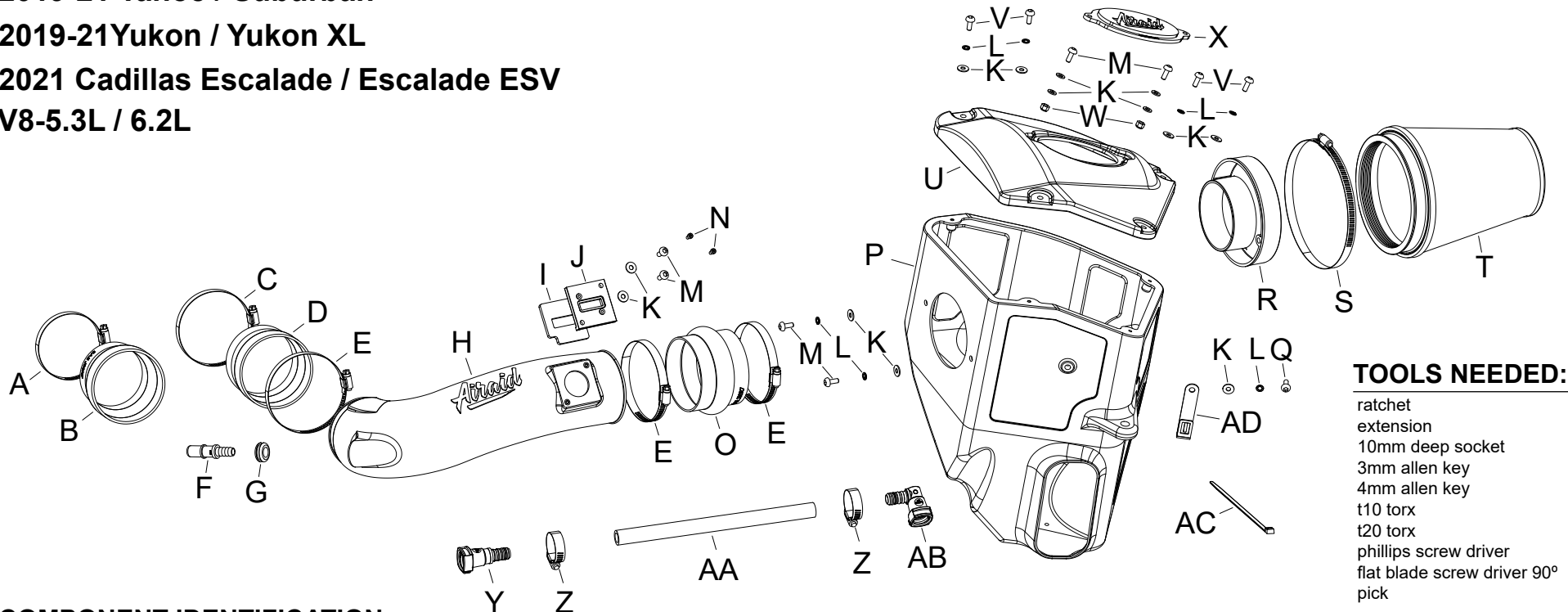

TOOLS NEEDED:

- ratchet
- extension
- 10mm deep socket
- 3mm allen key
- 4mm allen key
- t10 torx
- t20 torx
- phillips screw driver
- flat blade screw driver 90°
- pick

COMPONENT IDENTIFICATION

Description	Qty.	Part #	Description	Qty.	Part #	Description	Qty.	Part #
A HOSE CLAMP; #56	1	08620	K WASHER; 6MM FLAT	13	08269	U LID; (MG)	1	087423
B REDUCER; 4"ID X 3.5"ID X 3"L	1	KITRDCR18	L WASHER; M6 SPLIT LOCK ZINC	7	1-3025	V BOLT; M6 X 1 X 16MM	4	07730
C HOSE CLAMP; #60	1	08624	M SCREW; M6 X 20MM BTNHD	6	KIT20BHC3060	W NUT; 6MM NYLOCK, HEXHEAD	2	07512
D REDUCER; 4"ID X 3.875"ID X 2"	1	KITRDCR19	N BOLT; M4-.7 X 8MM, ALLEN	2	07733	X PLATE; AIRAID LOGO - CLEAR	1	KITLOGOP-1
E HOSE CLAMP; #64	3	08645	O HUMP HOSE; 4"ID X 3"L	1	KITHUMPHS22	Y FITTING; 16-14 PCV	1	08526
F FITTING; VENT 1/2" BARB	1	82629	P AIR BOX; (MH)	1	087424	Z HOSE CLAMP; #10 MINI	2	08411
G GROMMET; 1/2"ID - 1"OD (104)	1	KITGRMT03	Q BOLT; M6 X 1 X 12MM	1	07727	AA HOSE; 5/8"ID X 15"L	1	5-7015
H TUBE; (MF)	1	087422	R ADAPTOR; #454	1	27300	AB FITTING; ELBOW, PCV 90°	1	KITFITTING33
I GASKET; 3/16" PORON	1	09069	S CLAMP; #104, 9/16", SS	1	KITHS104	AC CABLE TIES; 11" BLACK	1	21590
J ADAPTOR; MAF SENSOR	1	21515-1	T AIR FILTER; CONE	1	700/701-469	AD BRACKET	1	064358A

Full color instructions can be viewed on our web site at Airaid.com. If you need any assistance please call 1-800-498-6951 to speak with a representative in our Customer Service Center before returning the product.

TO START:

1. Turn off the ignition and disconnect the negative battery cable.

NOTE: Disconnecting the negative battery cable erases pre-programmed electronic memories. Write down all memory settings before disconnecting the negative battery cable. Some radios will require an anti-theft code to be entered after the battery is reconnected. The anti-theft code is typically supplied with your owner's manual. In the event your vehicles anti-theft code cannot be recovered, contact an authorized dealership to obtain your vehicles anti-theft code.



2. Disconnect the mass air sensor electrical connection.



3. Depress the locking tabs and then disconnect the crank case vent line from the intake plenum and valve cover vent port.



4. Loosen the hose clamps that secure the intake plenum assembly to the throttle body and air filter housing. Disconnect the plenum from the air filter housing and then rotate the plenum assembly counter clockwise to disengage the keyed mount and then remove the plenum from the throttle body.



5. Remove the two bolts that secure the hood release arm to the hood latch and then remove the release arm.



6. Release the ten plastic locking pins holding the upper radiator valence and then remove the valence from the vehicle.

Continued...



7. Remove the plastic clip securing the fresh air intake duct onto the core support, then pull the duct forward to disengage it from the factory air filter housing.



8. Using a small 90° pick or similar tool, release the locking tap that secures the wiring harness bulk connector to the air filter housing and then unhook the connector from the housing. Unhook the wiring harness from the two locations held with tie wraps.



9. Remove the nut that secures the air filter housing assembly to the vehicle. Remove the air filter housing assembly from the vehicle.
NOTE: Go slow and use caution to remove the housing. It is indexed into two holes in the rear with rubber grommets that can fall off easily and be lost. It is a tight fit but will come out without being forced.
NOTE: AIRAID recommends that customers do not discard factory air intake.



10. Install the provided radius filter adapter into the AIRAID® air filter housing and secure with the provided hardware.



11. Install the provided wiring harness bracket onto the AIRAID® air filter housing and secure with the provided hardware.



12. Remove the two factory mounting grommets from the factory air filter housing and install them onto the AIRAID® air filter housing.



13. Install the AIRAID® air filter housing into the vehicle so the mounting grommets engage into the factory mounting holes. Secure the housing with the factory nut removed in step #9.



14. Push the factory fresh air intake duct into the AIRAID® air filter housing and then reinstall the plastic clip to secure it into position.



15. Clip the wiring harness onto the bracket installed onto the AIRAID® air filter housing.



16. Install the provided hump coupler onto the filter adapter and secure with the provided hose clamp.



17. Install the appropriate coupler onto the throttle body, The 5.3L engine will use the smaller coupler and the 6.2L engine will use the larger coupler. Secure with the provided hose clamps.



18. Install the provided gasket onto the provided mass air sensor adapter. Remove the mass air sensor from the factory air filter housing and then install it into the adapter and secure with the provide hardware.



19. Install the mass air sensor assembly into the AIRAID® intake tube in the direction shown and secure with the provided hardware.



20. Install the grommet and quick disconnect vent fitting into the AIRAID® intake tube as shown.



21. Assemble the crank case vent assembly using the provided hose, straight quick disconnect fittings and hose clamps as shown.

Continued...



22. Install the AIRAID® intake tube into the coupler at the air filter housing and then into the coupler on the throttle body, adjust the tube for best fit and then secure with the provided hose clamps.



23. Install the crank case vent hose assembly onto the valve cover port and onto the 90° fitting on the intake tube.



24. Install the AIRAID® air filter onto the filter adapter and secure with the provided hose clamp.



25. Reconnect the mass air sensor electrical connection. Use the provided tie wrap to secure the wiring harness to the A/C line with some slack for the wiring connector.



26. Install the AIRAID® window into the AIRAID® air filter housing lid and secure with the provided hardware.



27. Install the AIRAID® air filter housing lid onto the air filter housing and secure with the provided hardware.



28. Reinstall the upper radiator valence and secure with the factory retaining clips.



29. Reinstall the hood release arm to the hood latch and secure with the factory bolts.



30. Double check your work!

Make sure there is no foreign material in the intake path. Make sure all clamps, hoses, bolts, and screws are tight. Double check the hood clearance! **Reconnect the negative battery cable!**

31. **AIR AID AIR FILTER MONITOR LIGHT:** Some vehicles are equipped with a "Air Filter Monitor" system that will send a message to the instrument cluster indicating that the air filter needs to be replaced. This system is calibrated for the OEM intake system and air filter and will not be accurate when AIRAID products are in use. Always refer to WWW.AIR AID.COM for AIRAID air filter service procedures. The "Air Filter Monitor" system must be disabled to prevent the monitor from setting on and causing a factory dealership visit reset the system. Follow the "Air Filter Monitor" system procedure listed in the factory owners manual.

32. **NOTE:** Most General Motors vehicles have the Vehicle Emissions Certification Information (VECI) label affixed to the air filter box. In order to be compliant with California emissions laws, the label **MUST** remain in the engine compartment. If the Vehicle Emission Control Information label is removed during modification, a new replacement label must be obtained and installed in a readily visible position in the engine compartment. The label shall not be affixed to any equipment which is easily detached from the vehicle. We recommend that the label is affixed to the underside of the hood adjacent to the hood latch. The label is Vehicle Identification Number dependent and can be ordered from the vehicle dealership. In order to receive the proper decal please bring your VIN with you. Failure to have the VECI under the hood may result in failure of a pre-registration smog test.

Thank you for purchasing the Airaid Intake System. Contact Airaid @ (800) 498-6951 8:00 AM - 5:00 PM MST weekdays for questions regarding fit or instructions that are not clear to you. Your Airaid Intake System was carefully inspected and packaged. Check that no parts are missing, or were damaged during shipping. If any parts are missing, contact Airaid. The air filter element is protected from direct exposure to water and debris; care should be taken not to drive through deep water. **WATER INGESTION IS THE DRIVERS RESPONSIBILITY!** The air filter is reusable and should be cleaned periodically.

For your Oiled media filter we offer the Airaid Tune Up Kit!



P/N 790-551 Aerosol Spray
P/N 790-550 Squeeze Spray



NOT LEGAL FOR SALE OR USE ON ANY POLLUTION CONTROLLED MOTOR VEHICLE IN CALIFORNIA OR STATES ADOPTING CALIFORNIA EMISSION PROCEDURES.

See Airaid.com for CARB status on each part for a specific vehicle

SynthaMax

Synthamax Air Filters **do not** require oil. Service air filter as needed by cleaning with common non-petroleum all-purpose household cleaner and water. Simple Green®, Formula 409® or equivalent works great. Apply cleaner to outside of air filter and allow to soak. Then flush filter clean from the inside out with a garden hose and repeat steps if necessary. Do not apply high pressure water or air to clean filter. Allow filter to air dry and reinstall.