



Installation Instructions

For Part Number 200-639

CHEVROLET / GMC / CADILLAC

2014-22 Silverado 1500 / Sierra 1500

2014-22 Yukon / Yukon Denali

2014-22 Yukon XL / Yukon Denali XL

2015-22 Escalade / Escalade ESV

2018-22 Tahoe

2019-22 Suburban

V8-6.2L

Tools Needed:

- flat blade screw driver
- 10mm socket
- 13mm socket
- extension
- ratchet

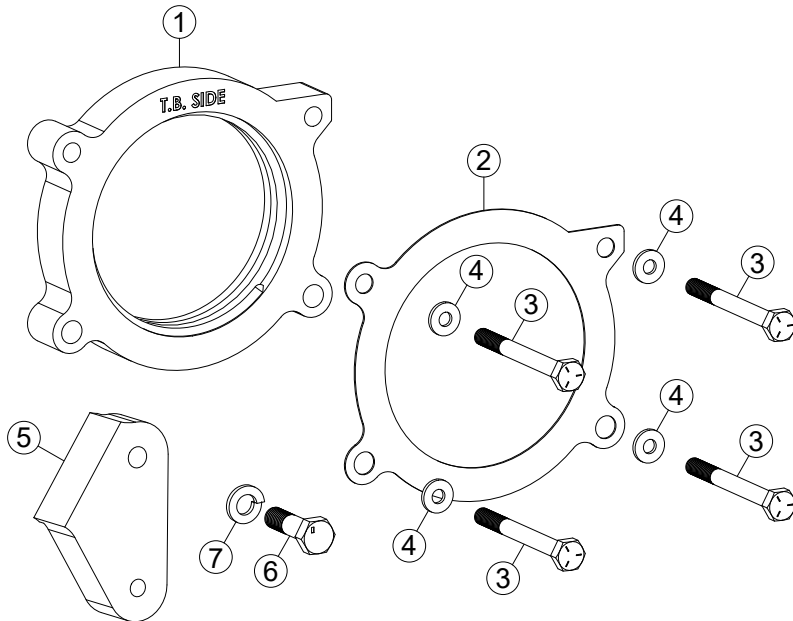

NOT LEGAL FOR SALE OR USE ON ANY POLLUTION CONTROLLED MOTOR VEHICLE IN CALIFORNIA OR STATES ADOPTING CALIFORNIA EMISSION PROCEDURES.

See Airaid.com for CARB status on each part for a specific vehicle

Component Identification

1	AIR-KIT639PA	Aluminum Plate	1
2	AIR-KIT639G	Gasket	1
	AIR-KIT639H	<u>Hardware</u>	
3		6mmx60mm Bolts	4
4		6mm Flat Washers	4
5		3/4" Extension Plate	1
6		8mmx30mm Bolt	1
7		8mm Split Lock Washer	1

Thank you for purchasing the AIRAID Throttle Body Spacer. Please read the instruction manual carefully before proceeding with the installation. Your AIRAID Throttle Body Spacer was carefully inspected and packaged. Check that no parts are missing, or were damaged during shipping. If you need any assistance please call 1-800-858-3333 to speak with a representative in our Customer Service Center before returning the product. Thank you for selecting AIRAID



1. **Disconnect the negative battery cable!** Disconnect the crank case vent line quick disconnect fittings from the intake plenum. Loosen the two hose clamps that secure the intake plenum to the throttle body and to the air filter housing, then remove the intake plenum from the vehicle.



2. On vehicles equipped with a intake plenum support brace secured to the passenger side cylinder head, remove the bolt shown securing the support bracket.

CONTINUED...



3. On vehicles equipped with the intake plenum support bracket, install the provided spacer between the bracket and cylinder head and secure with the provided hardware.

NOTE: The tap on the support bracket will be inserted into the hole of the spacer when properly installed.



4. Remove the four bolts that secure the throttle body to the intake manifold. Pull the throttle body away from the intake manifold without disconnecting the wiring harness.



5. Install the provided new bolts through the holes in the throttle body, through the holes in the provided gasket and through the AIRAID spacer. Start the new bolts into the inserts in the intake manifold being careful not to cross thread the bolts. Tighten the bolts in a cross pattern to the factory specifications.

NOTE: Be sure to install the spacer in the correct direction as noted on the spacer.



6. Reinstall the factory intake plenum, reconnect the crank case vent lines. **Reconnect the negative battery cable!**

The sound of power...The “whistle” means its working!

Contact your nearest Airaid dealer for an Airaid Intake System for your car, truck or SUV.

Airaid. 1455 Citrus St., P.O. Box 1329, Riverside, CA. 92502 1-800-498-6951 AiraidInfo@airaid.com www.airaid.com

AIR-I20639H
REV 9/13/22