

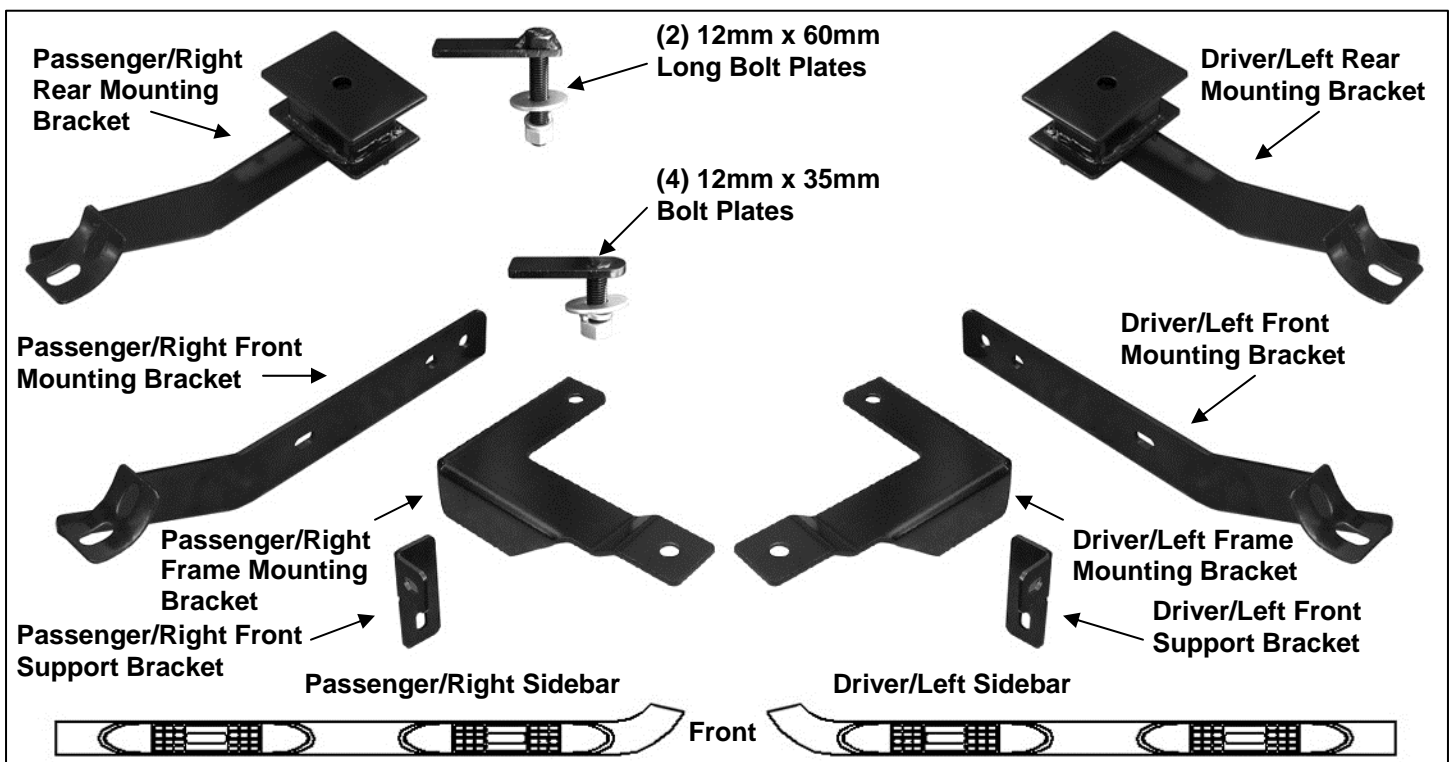
# **INSTALLATION INSTRUCTIONS**

**3" SIDEBAR**

**07-14 JEEP PATRIOT**

**PARTS LIST:**

1	Driver/Left Sidebar	10	12mm Lock Washers
1	Passenger/Right Sidebar	14	12mm x 37mm OD x 3mm Flat Washers
1	Driver/Left Front Mounting Bracket	10	12-1.75mm Hex Nuts
1	Passenger/Right Front Mounting Bracket	2	10-1.5mm x 35mm Hex Bolts
1	Driver/Left Front Frame Bracket	2	10mm Lock Washers
1	Passenger/Right Frame Bracket	4	10mm x 30mm OD x 2.5mm Flat Washer
1	Driver/Left Front Support Bracket	2	10mm Hex Nuts
1	Passenger/Right Front Support Bracket	2	8-1.25mm x 35mm Hex Bolts
1	Driver/Left Rear Mounting Bracket	8	8-1.25mm x 25mm Hex Bolts
1	Passenger/Right Rear Mounting Bracket	10	8mm Lock Washers
4	12-1.75mm x 35mm Bolt Plates	12	8mm x 24mm OD x 2mm Flat Washers
2	12-1.75mm x 60mm Long Bolt Plates	2	8mm Hex Nuts
4	12-1.75mm x 35mm Hex Bolts		



**PROCEDURE:**

**REMOVE CONTENTS FROM BOX. VERIFY ALL PARTS ARE PRESENT. READ INSTRUCTIONS CAREFULLY BEFORE STARTING INSTALLATION. DRILLING AND CUTTING IS REQUIRED. ASSISTANCE IS RECOMMENDED.**

- Starting at the driver side front of the vehicle, locate the three factory holes, (1 round and 2 oval holes), in the bottom of the left front floor panel, **(Figure 1)**. Insert (1) 12mm x 35mm Bolt Plate into the smaller, (inner), oval hole and feed the threaded end back out through the larger, (outer), oval hole, **(Figures 2A & 2B)**. Next, insert (1) 12mm Bolt Plate into the oval hole in the bottom of the inner frame channel, **(Figure 3)**.

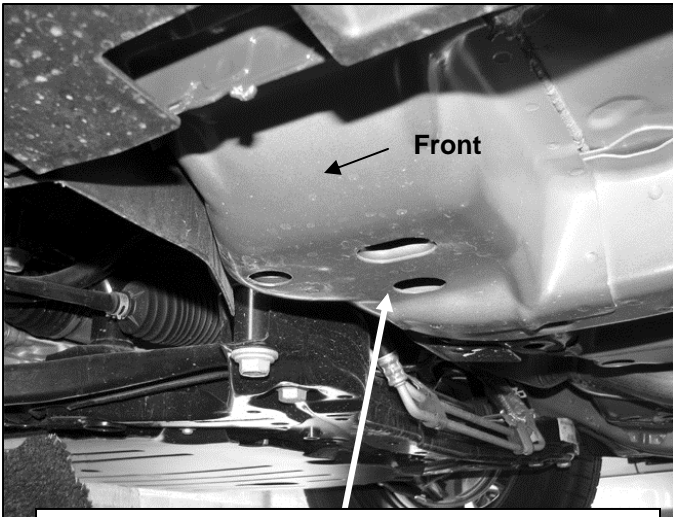
2. Attach the driver side front Frame Mounting Bracket to the (2) Bolt Plates with the included (2) 12mm Flat Washers, (2) 12mm Lock Washers and (2) 12mm Hex Nuts, **(Figure 4)**. Do not tighten hardware at this time.
3. Select the driver/left front Sidebar Mounting Bracket. Bolt the Mounting Bracket to the back of the Frame Bracket with the included (2) 12mm Hex Bolts, (4) 12mm Flat Washers, (2) 12mm Lock Washers and (2) 12mm Hex Nuts, **(Figure 5B)**. Do not tighten at this time.
4. Next, select the driver side Front Support Bracket, **(Figure 5A)**. Attach the Support Bracket to the front side of the Mounting Bracket with (1) 10mm Hex Bolt, (2) 10mm Flat Washers, (1) 10mm Lock Washer and (1) 10mm Hex Nut, **(Figure 5B)**. Leave completely loose at this time.
5. Move along the side of the vehicle toward the rear. Locate the large oval slot in the floor panel. Insert (1) 12mm x 60mm Long Bolt Plate into the slot, **(Figure 6A)**. **NOTE:** Rotate the Bolt Plate so that the plate is across, not inline with the oval hole, **(Figure 6B)**.
6. Attach the driver side rear Mounting Bracket to the Long Bolt Plate with (1) 12mm Flat Washer, (1) 12mm Lock Washer and (1) 12mm Hex Nut **(Figure 7)**.
7. With the Sidebar Bracket hardware loose, pull the Brackets outward away from the vehicle for proper clearance.
8. Select the driver/left Sidebar and carefully place it onto the (2) Mounting Brackets. Attach the Sidebar to the Brackets with the included (4) 8mm x 25mm Hex Bolts, (4) 8mm Lock Washers, and (4) 8mm Flat Washers **(Figures 7 - 9)**. Leave loose at this time.
9. Line up the Front Support Bracket with the back of the pinch weld, **(Figure 8)**. Push the Support Bracket up as high as possible to where the pinch weld meets the floor panel. Snug but do not fully tighten hardware.
10. Check the Sidebar for level. Once properly aligned and adjusted, tighten all hardware. **IMPORTANT:** If the Support Bracket is too low and close to the edge of the pinch weld, loosen the Support Bracket and front Bracket hardware. Push the Bracket and Support Bracket up a little into position against the floor panel and away from the edge of the pinch weld, **(Figure 8)**. Level and adjust the Sidebar properly and tighten all hardware.
11. Use the hole in the Support Bracket as a guide to mark the drilling location on the back of the pinch weld, **(Figure 8)**. Once you have marked the location, temporarily remove the Sidebar, the front Mounting Bracket and Support Bracket. Remove the plastic clips securing the plastic rocker cover to the rocker panel.
12. Use a 5/16" drill bit and carefully drill the marked location. **NOTE:** The plastic rocker panel cover may need to be trimmed to clear the hex bolt for the Support Bracket. **IMPORTANT:** Any cutting or drilling tool may break or shatter. Government regulations require safety glasses & equipment at all times when cutting or drilling.
13. Re-install the driver side front Mounting Bracket and Support Bracket. Attach the Support Bracket to the pinch weld with (1) 8mm x 35mm Hex Bolt, (1) 8mm Lock Washer, (2) 8mm Flat Washers and (1) 8mm Hex Nut, **(Figure 9)**. **NOTE:** Insert the 8mm Hex Bolt with (1) 8mm Flat Washer through the pinch weld first, then through the Bracket. Cut the rocker panel cover as required and reinstall the cover with the factory plastic clips. Reinstall the Sidebar.
14. Align and adjust the Sidebar and Brackets and tighten all hardware.
15. Repeat **Steps 2 – 14** for passenger Sidebar installation.
16. Do periodic inspections to the installation to make sure that all hardware is secure and tight.

**To protect your investment**, wax this product after installing. Regular waxing is recommended to add a protective layer over the finish. Do not use any type of polish or wax that may contain abrasives that could damage the finish.

**For stainless steel:** Aluminum polish may be used to polish small scratches and scuffs on the finish. Mild soap may be used also to clean the Sidebar.

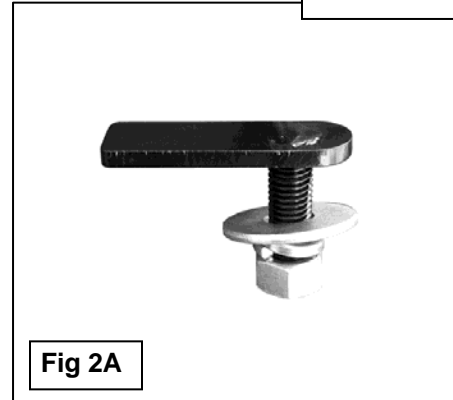
**For gloss black finishes:** Mild soap may be used to clean the Sidebar

### Driver Side Installation Pictured

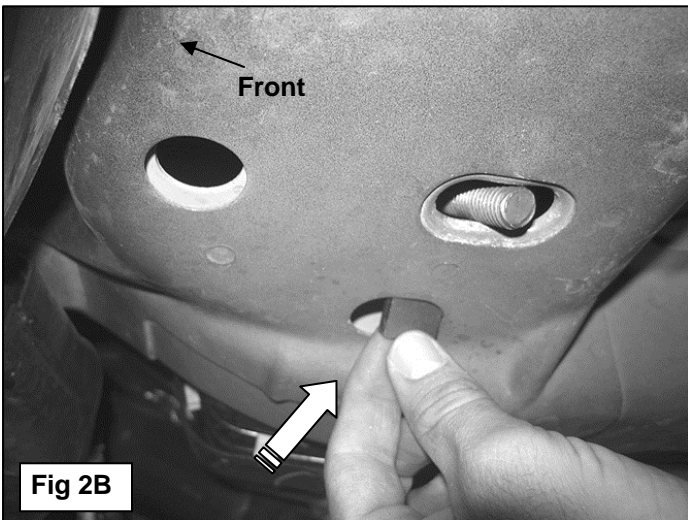


**(Fig 1) Driver side front mounting location**

12mm Bolt Plate  
12mm Flat Washer  
12mm Lock Washer  
12mm Hex Nut

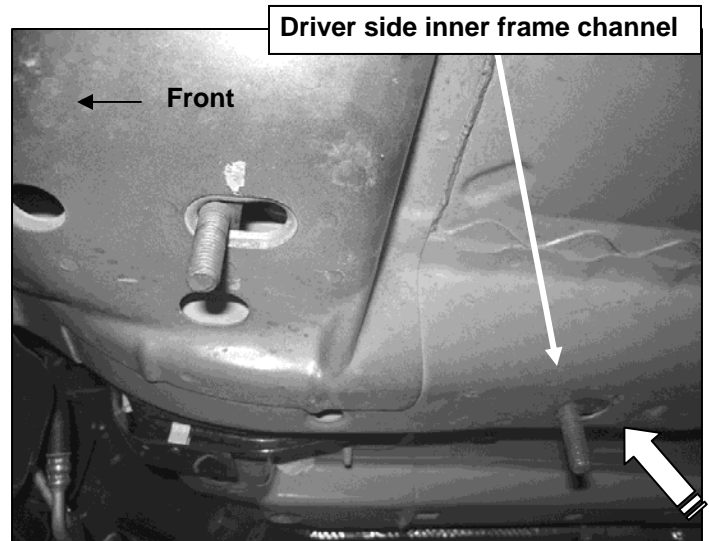


**Fig 2A**



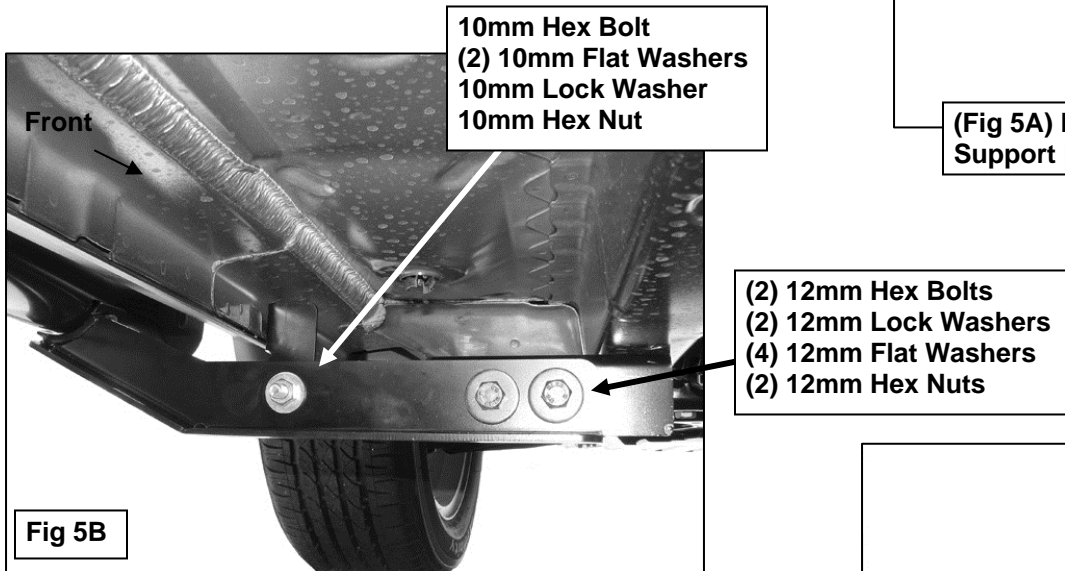
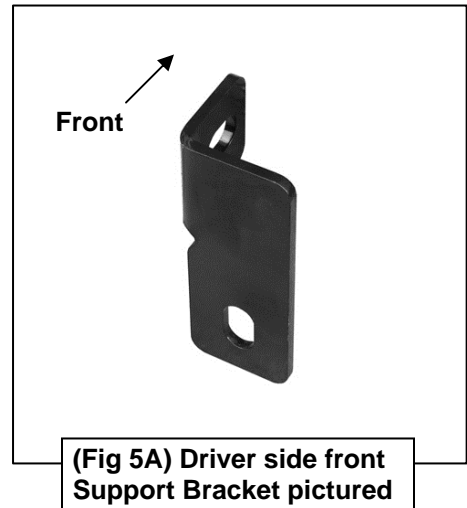
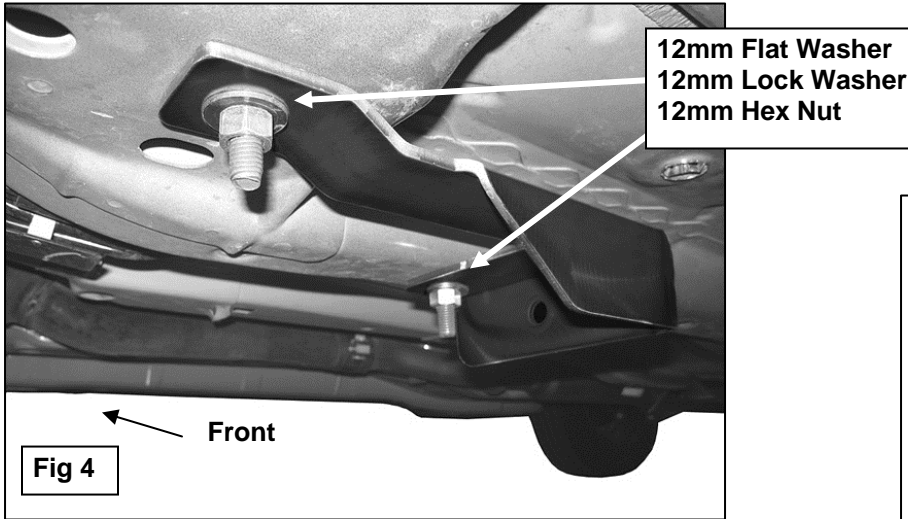
**Fig 2B**

Insert (1) 12mm Bolt Plate into the inner small oval hole and back out the larger oval hole

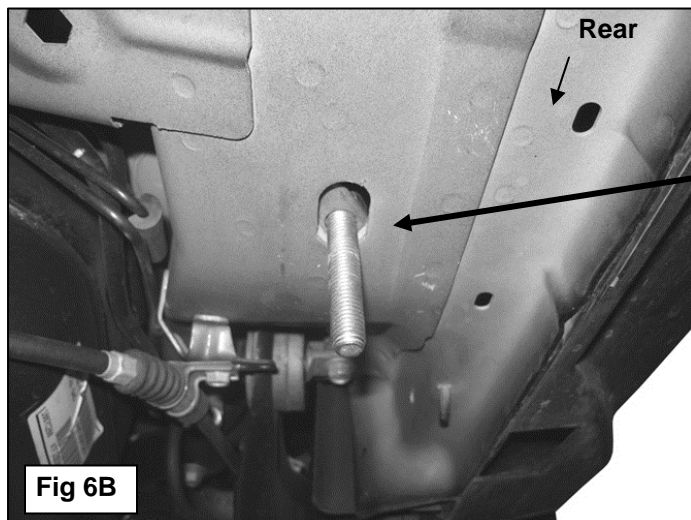
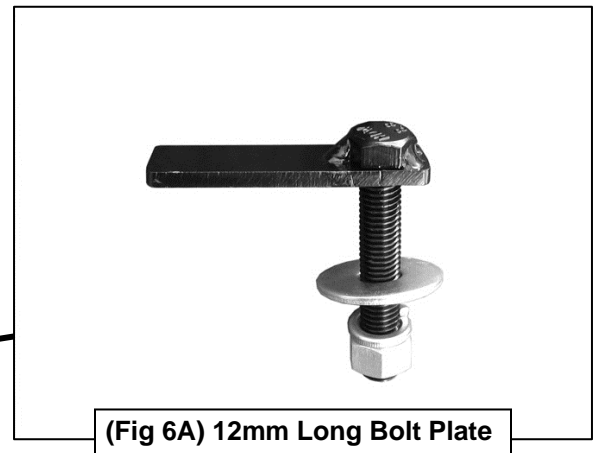


**(Fig 3) Insert (1) 12mm Bolt Plate into the hole in the bottom of the inner frame channel**

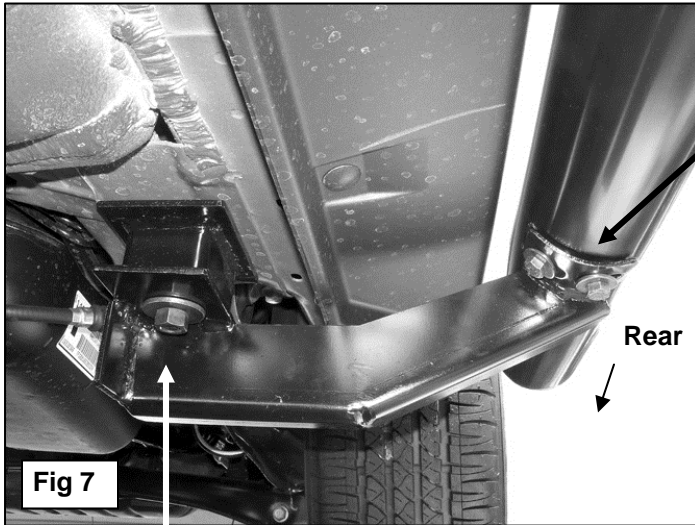
### Driver Side Installation Pictured



- (2) 12mm Hex Bolts
- (2) 12mm Lock Washers
- (4) 12mm Flat Washers
- (2) 12mm Hex Nuts

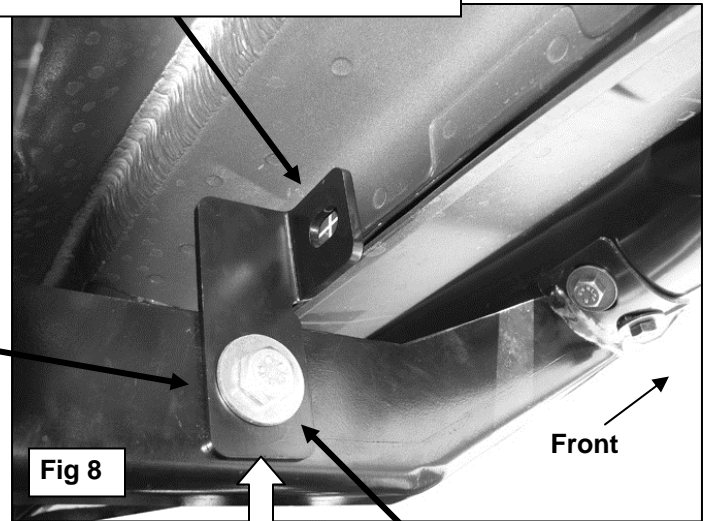


### Driver Side Installation Pictured



- (2) 8mm x 25mm Hex Bolts
- (2) 8mm Lock Washers
- (2) 8mm Flat Washers

Drill 5/16" hole through marked spot on pinch weld. Do not drill close to the edge of the pinch weld

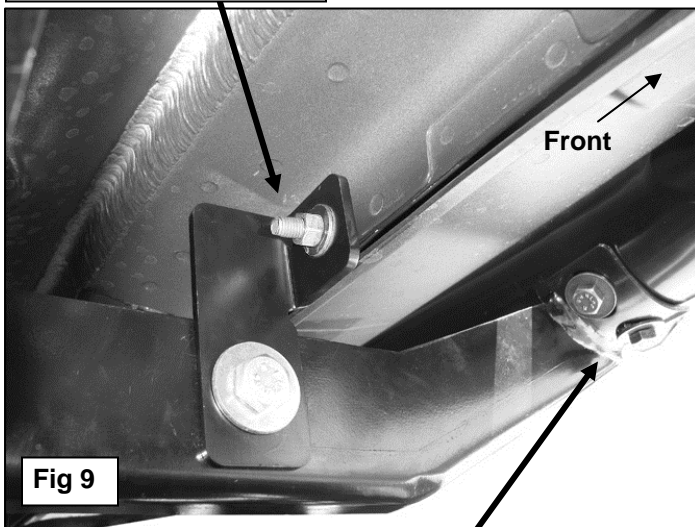


- 12mm Flat Washer
- 12mm Lock Washer
- 12mm Hex Nut

- 10mm Hex Bolt
- (2) 10mm Flat Washers
- 10mm Lock Washer
- 10mm Hex Nut

- 8mm x 35mm Hex Bolt
- 8mm Lock Washer
- (2) 8mm Flat Washers
- 8mm Hex Nut

Adjust Sidebar. Loosen 10mm Bolt and push Support Bracket up against the floor to move slot away from edge of pinch weld



- (2) 8mm x 25mm Hex Bolts
- (2) 8mm Lock Washers
- (2) 8mm Flat Washers

