

Parts List

1	Driver / left side bar
1	Passenger / right side bar
1	Driver / left mounting bracket, front
1	Passenger / right mounting bracket, front
1	Driver / left mounting bracket, middle
1	Passenger / right mounting bracket, middle
1	Driver / left mounting bracket, rear
1	Passenger / right mounting bracket, rear
12	Hex bolt, M10 - 1.50mm x 30mm
5	Button head bolt plate, M10 x 30mm
1	Small T-bolt, M10 x 35mm (driver front inner only)
2	T-bolt, M10 x 30mm (front outer)
20	Flat washer, M10 x 25mm x 2mm
20	Lock washer, M10
8	Hex nut, M10
8	Plastic retainer, M10
2	Bolt plate (rear), M12 x 35mm, rear
2	Flat washer, M12 x 30mm x 3mm
2	Lock washer, M12
2	Hex nut, M12
2	Plastic retainer, M12

Torque Specifications

METRIC		
M6 bolt		3 ft.-lbs.
M8 bolt		7 ft.-lbs.
M10 bolt		16 ft.-lbs.
M12 bolt		28 ft.-lbs.
SAE		
1/4" bolt		3 ft.-lbs.
5/16" bolt		7 ft.-lbs.
3/8" bolt		16 ft.-lbs.
7/16" bolt		20 ft.-lbs.
1/2" bolt		28 ft.-lbs.

Level of Difficulty

Easy



Scan for helpful install tips

Product Image



Brackets and Hardware

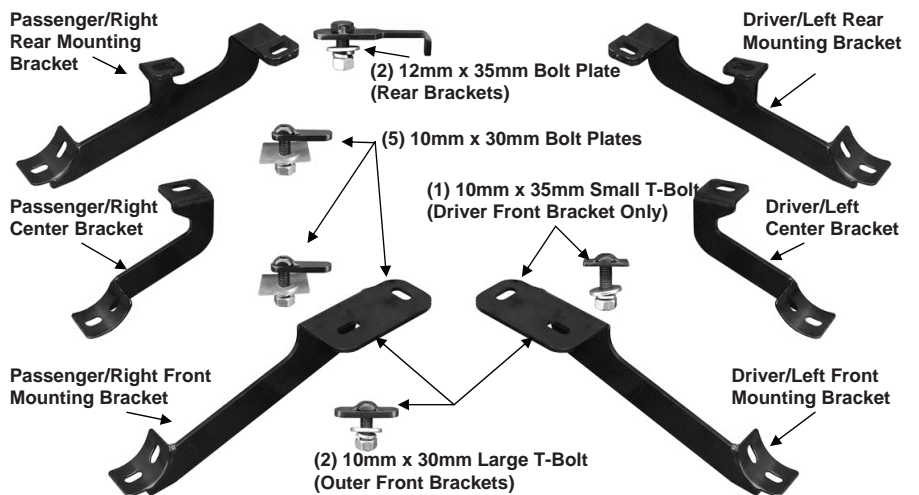

Notes and Maintenance

Before you begin installation, read all instructions thoroughly.

Proper tools will improve the quality of installation and reduce the time required.

To protect the product, wax after installing. Regular waxing is recommended to add a protective layer over the finish. Do not use any type of polish or wax that may contain abrasives that could damage the finish.

For gloss black finishes, mild soap may be used to clean the product.

Refer to the table to the left when securing hardware during the installation process to help prevent damage to the product or vehicle.

PROCEDURE:

1. REMOVE CONTENTS FROM BOX. VERIFY ALL PARTS ARE PRESENT. READ INSTRUCTIONS CAREFULLY BEFORE STARTING INSTALLATION. CUTTING IS REQUIRED. ASSISTANCE IS RECOMMENDED.

2. Start installation under the driver side of the vehicle. **NOTE:** To help determine the correct mounting holes to use, hold the front Bracket up in position against the floor panel and line up the Bracket with the correct holes, (Fig. 1).

a. Driver side front Bracket installation:

Select (1) M10 x 30mm Small T-Bolt and (1) 10mm Plastic Retainer, (Fig. 2A). Partially thread the Retainer onto the T-Bolt. Insert the T-Bolt into the inner factory oval hole, (Fig. 1 & 3). Rotate the T-Bolt 90-degrees so that the plate is across the slot. Thread the Retainer down until it is tight against the floor panel. The Retainer is designed to help hold the T-Bolt in place during Bracket installation.

Next, insert (1) M10 x 35mm Large T-Bolt with (1) Plastic Retainer into the outer oval hole in the floor panel next to the pinch weld as previously described, (Fig. 2B & 3).

b. Passenger side front Bracket installation:

IMPORTANT-Repeat the previous **Step 2a** for passenger side Bracket installation but note that the inner mounting tab on the front Bracket will use (1) M10 x 30mm Button Head Bolt Plate, (same bolt plate as used on center and rear Brackets), inserted into a round hole in place of the M10 Small T-Bolt, (Fig. 2B, 4 & 5). Do not use the Small T-Bolt for passenger side Bracket.

3. Hang the driver side Front Bracket from the T-Bolts with (2) 10mm Flat Washers, (2) M10 Lock Washers and (2) M10 Hex Nuts, (Fig. 6). Do not tighten hardware at this time.

4. Release the plastic clips attaching the lower plastic rocker panel cover to the body, (Fig. 7).

5. Measure 40" back from the bottom corner of the wheel opening to locate the correct factory hole under the plastic rocker cover for the center Bracket, (Fig. 8). Pull plastic cover outward to access the hole, (Fig. 10). Partially thread (1) 10mm Plastic Retainer onto (1) M10 x 30mm Button Head Bolt Plate, (Fig. 9). Insert Bolt Plate into the round hole and thread the Retainer down against the body, (Fig. 10).

6. Select the driver side center Bracket, (Fig. 11A). Insert the Center Bracket into the approximate position, (Fig. 11B). Mark the Bracket location on the bottom edge of the plastic cover, (Fig. 12). Cut a small slot in the bottom edge of the cover to clear the Bracket. Bolt the Bracket to the Bolt Plate with (1) 10mm Flat Washer, (1) M10 Lock Washer and (1) M10 Hex Nut, (Fig. 13). Do not tighten hardware at this time.

7. Move to the rear location and remove the plastic cover on the floor panel, (Fig. 14). Locate the small round hole under the plastic rocker cover, (Fig. 16). Select (1) M10 x 30mm Button Head Bolt Plate and (1) 10mm Plastic Retainer (Fig. 15). Insert the Bolt Plate into the round hole as described in **Step 5**, (Fig. 16 & 17).

8. Next, locate the large round hole in the floor panel. Insert (1) M12 x 35mm Bolt Plate into the large round hole and out the smaller hole toward the front, (Fig. 18 & 19). Slide the driver side Rear Bracket under the plastic rocker cover and over the (2) Bolt Plates, (Fig. 20). Secure the Bracket to the outer 10mm Bolt Plate with (1) 10mm Flat Washer, (1) M10 Lock Washer and (1) M10 Hex Nut. Attach the Bracket to the Larger M12 Bolt Plate with (1) 12mm Flat Washer, (1) M12 Lock Washer and (1) M12 Hex Nut. , (Fig. 20). Do not tighten hardware at this time.

9. Hold the plastic cover removed in **Step 7**, up in position. Trace the location of the rear Bracket onto the cover, (Fig. 21). Carefully cut the cover to clear the Bracket, (Fig. 22A & 22B). **IMPORTANT:** Cut as little as possible from the cover. Do not cut off the mounting area for the factory hardware, (Fig. 22B). Reinstall the plastic cover and all plastic clips holding the bottom of the rocker cover to the body panel. Check the direction of the cradles on all Brackets before proceeding, (Fig. 23).

10. Carefully unwrap and select the driver Sidebar. Place the Sidebar in position on top of the (3) Brackets. **NOTE:** It may be necessary to loosen the Brackets slightly to line up the cradles with the threaded inserts in the Sidebars. Bolt the Sidebar to the Brackets with (6) M10 x 30mm Hex Bolts, (6) M10 Lock Washers and (6) 10mm flat washers, (Fig. 24).

11. Level and adjust the Sidebar and tighten all hardware.

12. Repeat **Steps 2 – 11** for passenger Sidebar installation. **NOTE:** See specific passenger side front Bracket installation info in **Step 2b**.

13. Do periodic inspections to the installation to make sure that all hardware is secure and tight.

Driver/Left Side Installation Pictured

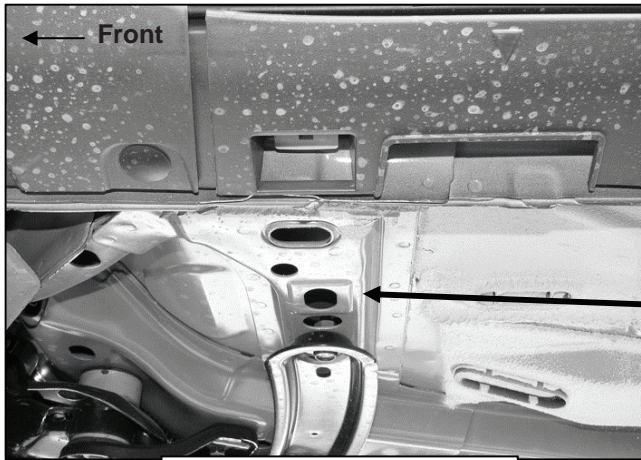

(Fig 1) Driver side front mounting location pictured

(Fig 2A) Small M10 x 35mm T-Bolt for driver side inner front bracket only

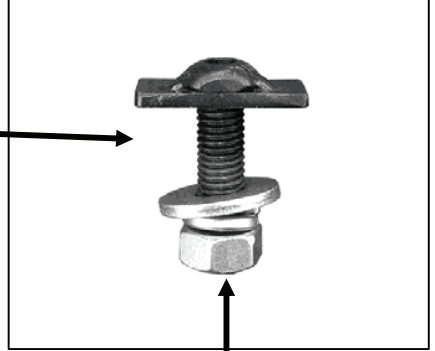

(Fig 2B) Large M10 x 30mm T-Bolt for driver and passenger side outer location on front brackets only

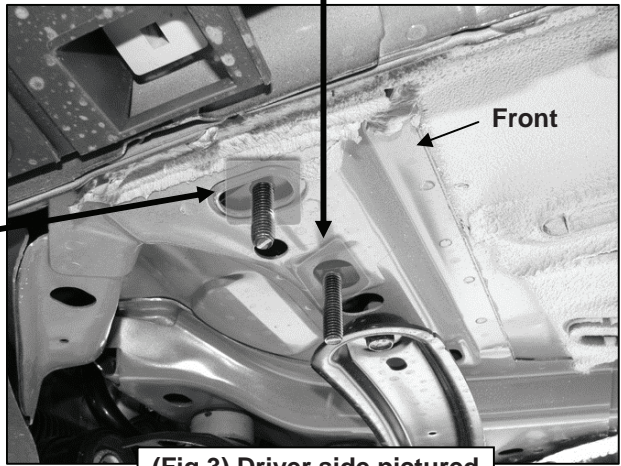
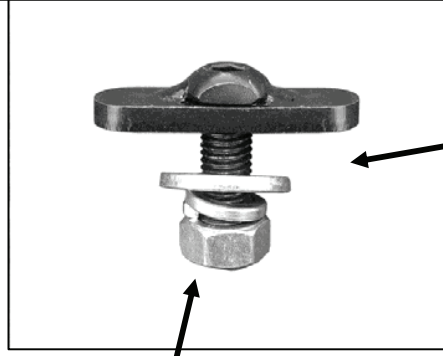

(Fig 3) Driver side pictured

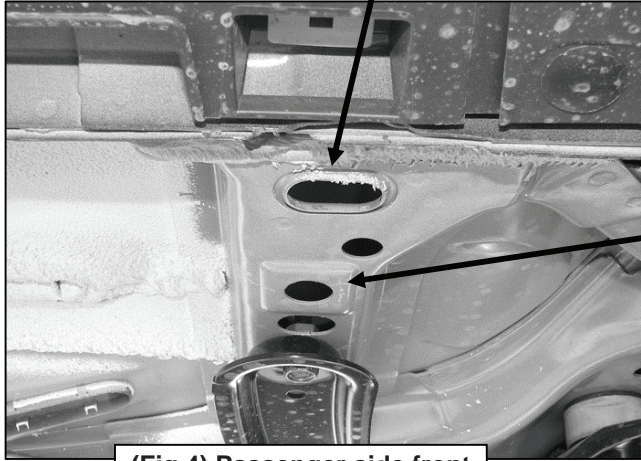

(Fig 4) Passenger side front mounting location pictured

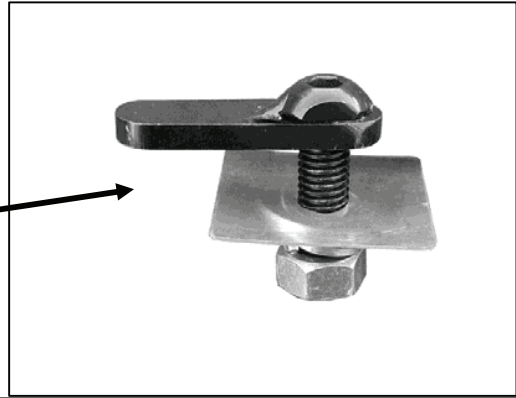

(Fig 5) Use M10 x 30mm Bolt Plate for passenger side inner location (same bolt plate used on center and rear brackets)

Driver Side Installation Pictured

(2) 10mm Flat Washers
(2) M10 Lock Washers
(2) M10 Hex Nuts

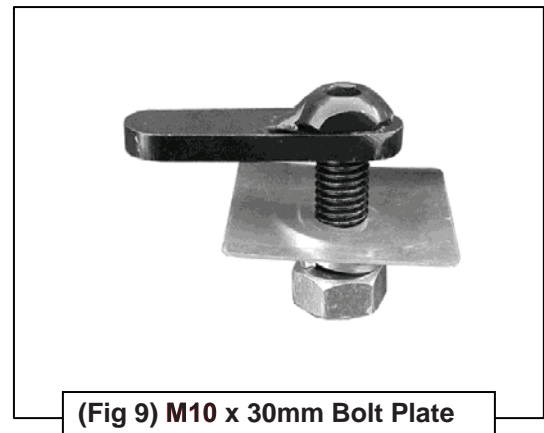
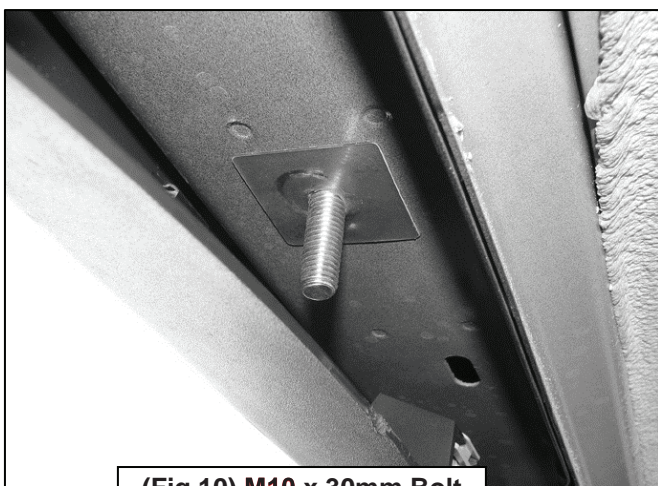
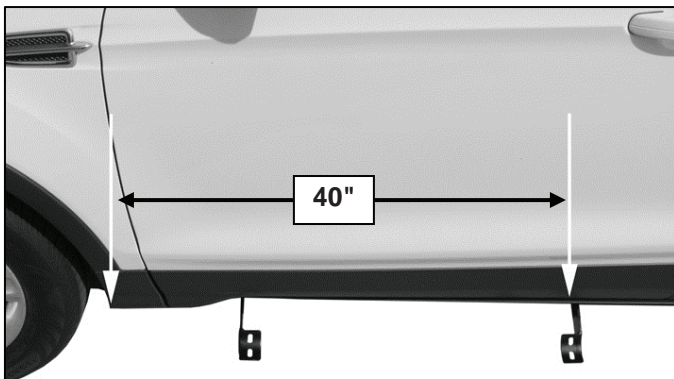
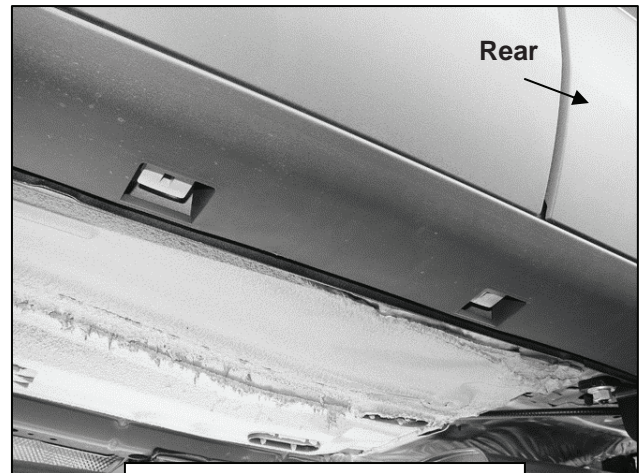
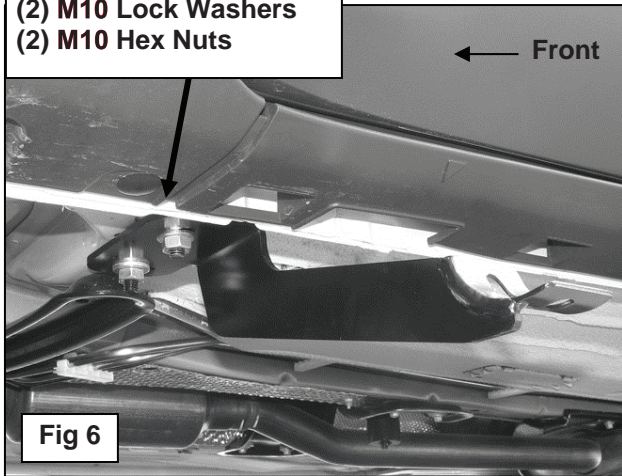

Driver Side Installation Pictured

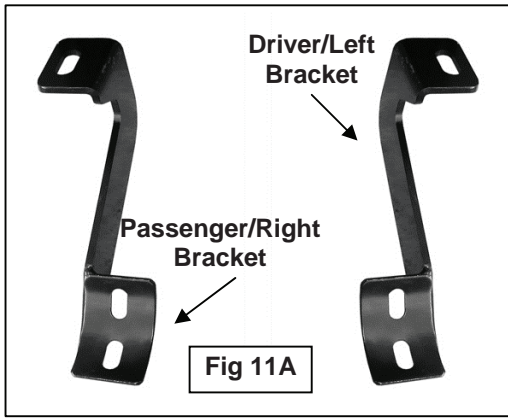

(Fig 11B) Hold correct center Bracket up in place to determine area to cut from bottom edge of rocker panel cover

- 10mm Flat Washer
- M10 Lock Washer
- M10 Hex Nut

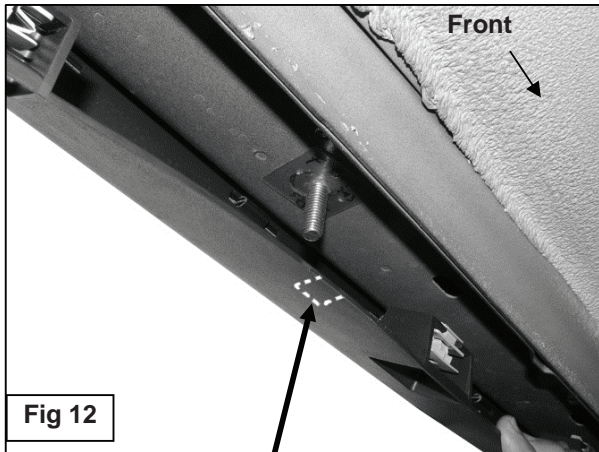

Fig 12

Dotted line represents area to cut from bottom edge of rocker panel cover to clear center Bracket

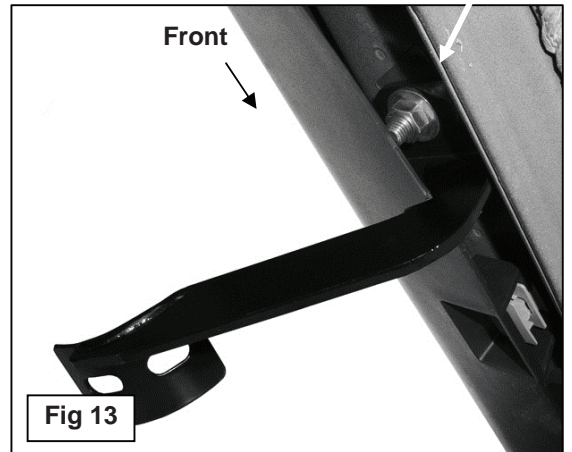
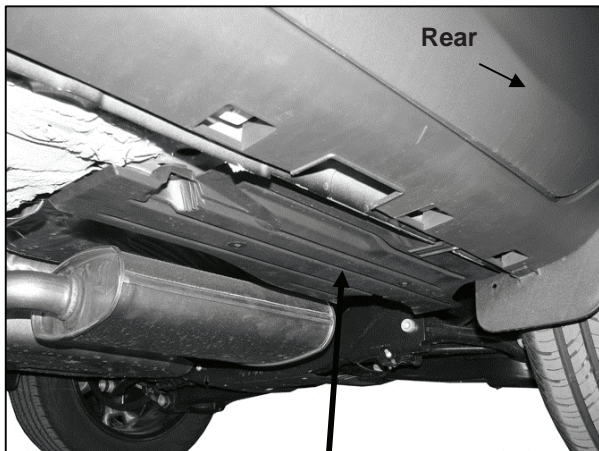
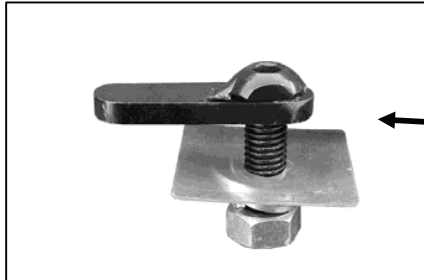

Fig 13



(Fig 14) Remove plastic cover

Driver Side Installation Pictured



(Fig 15) M10 x 30mm Bolt Plate

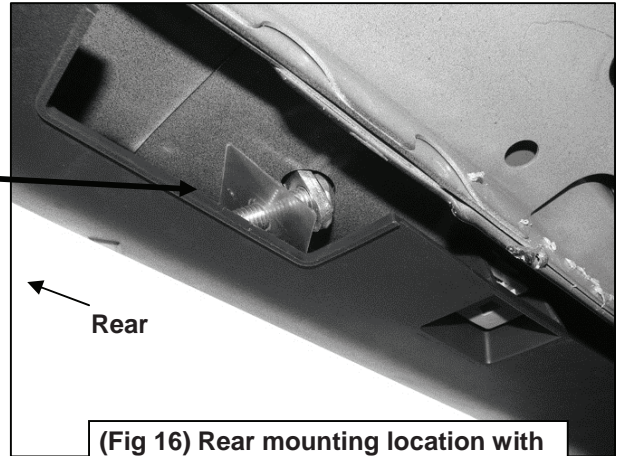

(Fig 16) Rear mounting location with Bolt Plate pictured from below

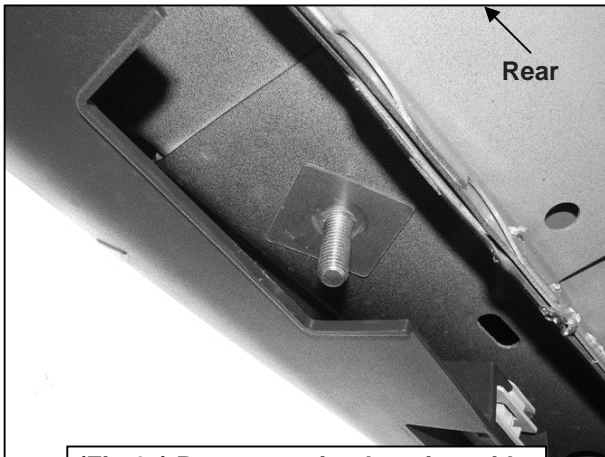

(Fig 17) Rear mounting location with Bolt Plate pictured from below

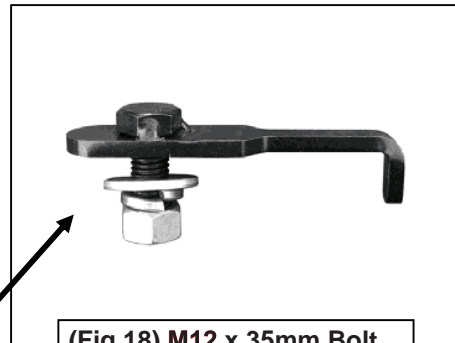

(Fig 18) M12 x 35mm Bolt Plate for rear Bracket only

12mm Flat Washer
M12 Lock Washer
M12 Hex Nut

10mm Flat Washer
M10 Lock Washer
M10 Hex Nut

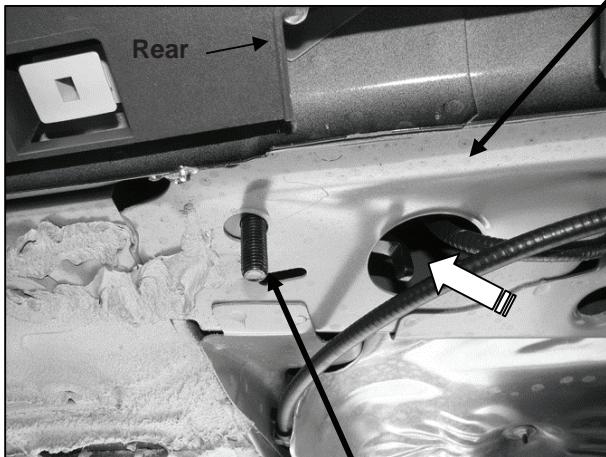

(Fig 19) Insert 12mm Bolt Plate into large hole and out smaller hole



(Fig 20) Rear Bracket pictured from below

Driver Side Installation Pictured



(Fig 21) Hold plastic cover up in position to determine area to cut from cover

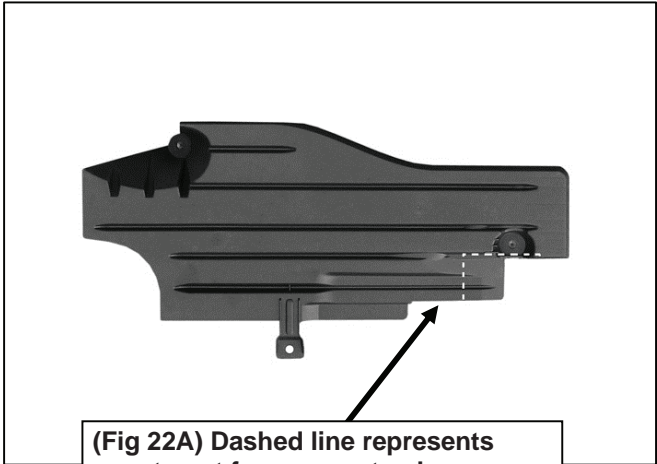

(Fig 22A) Dashed line represents area to cut from cover to clear

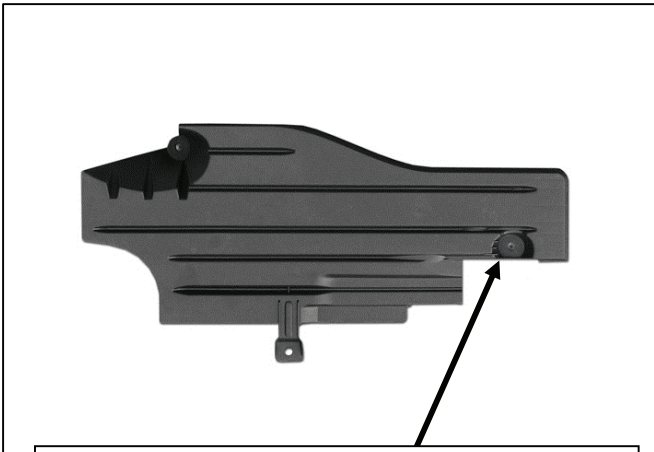

(Fig 22B) Do not cut mounting area off of cover

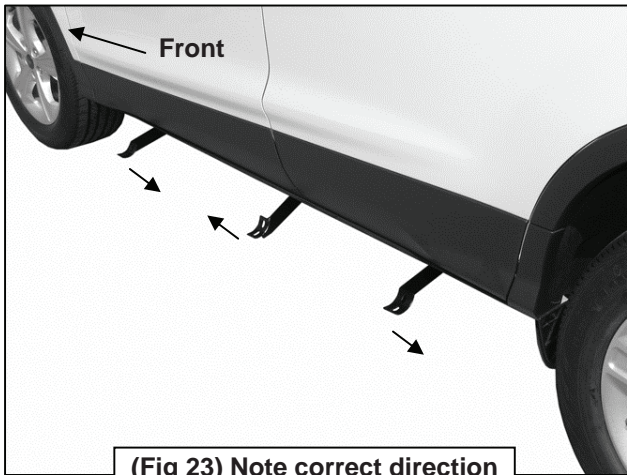

(Fig 23) Note correct direction of cradles on Brackets

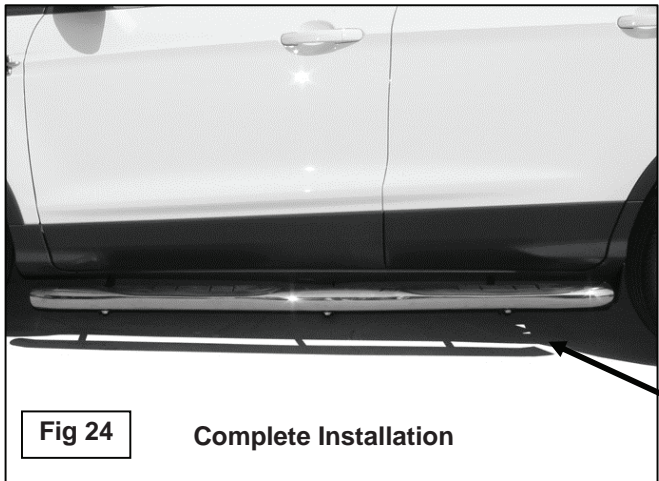

Fig 24 Complete Installation

- M10 x 30mm Hex Bolts
- M10 Flat Washers
- M10 Lock Washers