

Index

alarm light, wiring label, 3
alarms, 27
calibrating sensors, 30
CAN-USB, wiring label, 3
checks and alarms, 29
clearing an alarm, 27
configuration, 28
configuration memory, 28
contact breaker connection, 12
contacting your dealer, 37
data logging, 29
digital display panel, 4
display module, 4
display module, template, 33
EGT sensor, 17
electronic ignition), 12
engine control unit), 12
engine speed (RPM), 11
engine speed (RPM), label, 3
exhaust gas temperature, 17
external warning light, 9
fitting multi-function dash
 logger module, 7
fluid pressure sensor, 15
fluid temperature sensor, 16
frequently asked questions, 37
gate value, 26
gear shift light, wiring label, 3
gear shift warning light, 1
hydraulic pressure sensor, 19
installing the multi-function
 dash-logger, 7
labels on wiring, 3
lap times, 29
lap timing sensor, 21
lap timing sensor, wiring label, 3
lap timing system, 21
light functions, 36
linear displacement sensor, 18
multi-stage shift light, 11
peak values, 26
peak values, resetting, 26
performance parameters, 1
points connection, 12
position sensor, 17
power supply, 6
power supply to trackside
 beacon, 23
proximity sensors, 13
recording data, 29
resetting the peak values, 26
RPM gate value, 26
service and support, 37
service enquiries, 38
shift light, multi-stage, 11
shift light, single, 10
shift lights, 10
Stack contact details, 41
Stack web-site, 37
standard components, 2
switches, 8
switches, wiring label, 3
tachometer, 4
tell tales, 26
template, display module, 33
throttle position sensor, 17
tools needed, 7
trackside infra-red lap beacon,
 22
transmission sensors, 13
unpacking, 2
warning lights, 9
wheel speed sensors, 13
wires in the harness, labels, 3
wiring harness, 3
wiring harness diagram, 35
wiring harness, installation, 24



ST8916 Multi-Function Dash-Logger

Users Guide

with this work, we will return the goods to you as we received them and you will only be charged for the initial inspection and return freight.

Harnesses and Sensors – Where goods returned include harnesses and sensors we will provide an inspection of that equipment to assess the functionality. We are unable to repair harnesses or sensors that have been cut or become damaged due to use.

Note: a small number of our sensors can be serviced or repaired. Please discuss with your dealer who will advise you of which sensors are serviceable.

Loan/Replacement equipment – Stack operate a return to base service and repair policy. We do not offer an advance exchange or loan scheme.

Stack Contact Details

Contact	International	United States
Email:	sales@stackltd.com	sales@stackinc.com
Web:	www.stackltd.com	www.stackinc.com

4. Once we have confirmation that payment has been received for this service, the goods will be returned to you.

Cost and Duration of Service

All service and repair work is conducted at Stack's factory in the UK. Both the cost and the duration of the service will depend on:

- Your Geographical location.
- Whether the goods are covered by a warranty.
- The complexity of the repair work required once the initial inspection has been completed.

Cost and Duration of Inspection – Your dealer will be able to advise on the cost of the initial inspection work. As stated above it is your responsibility to arrange for the safe shipment of the goods.

The time required to complete any service or repair work is dependent on the outcome of the initial inspection. At the time of receiving your RAN form, we will provide an estimated delivery time, which is subject to the outcome of the initial inspection.

Priority Service – If you require your goods to be returned faster than the estimated delivery time, we can offer a priority service, for which there will be an extra charge. Again, the time required to complete any service or repair work is dependent on the outcome of the initial inspection. Wherever possible we will return the goods within our priority delivery times:

- **UK - 2-3 working days**
- **USA & Rest of World - 7 working days**

Cost and Duration of Service and Repair – On completion of the initial inspection, we will be able to quote the final cost and expected duration of the service and any repair work. We will contact you for authorisation to complete the work and request payment. If you choose not to proceed

Preface

Congratulations

Congratulations on choosing the Stack ST8916 Multi-Function Dash-Logger. This system will give you a wealth of information to enable you to obtain the maximum performance from your vehicle.

Purpose of this manual

This manual will help you install and use the Stack ST8916 Multi-Function Dash-Logger. It explains how to set up and configure the system for your vehicle.

Related Products From Stack

If you need information about other Stack motor sport products, these can be obtained from Stack or from your local Stack dealer. Products available from Stack include:

- Intelligent Tachometers
- Auxiliary Gauges
- Analogue and Digital Sensors
- Data Logging Systems
- Display and Logging Systems
- Radio Telemetry Systems
- Display and Analysis Software
- Video Overlay Systems
- Solid-state Video Recorders
- Tyre Pressure Monitoring Systems

Stack ® is a registered trademark of Stack Limited.

Information in this publication is subject to change without notice and does not represent a commitment on the part of Stack Limited. No responsibility is accepted for error or omission.

Copyright © 2009 Stack Limited

Contents

Chapter 1. Introducing the Multi-Function Dash-Logger	1
How to use this Manual	1
Chapter 2. Getting Started	2
The Multi-Function Dash-Logger Module	4
Wiring Harness	4
The Display Module	5
Connecting the Components	5
Chapter 3. Installing the Multi-Function Dash-Logger	8
Who can install the Multi-Function Dash-Logger?	8
Tools needed	8
Fitting the Multi-Function Dash-Logger Module	8
Switches	9
Warning lights	10
External Shift Lights (optional)	11
Single Shift Light	11
ST539 Multi-Stage Shift Light Module	11
Engine Speed (RPM) Measurement	12
Wheel speed and transmission sensors	14
Fluid Pressure Sensors	16
Fluid Temperature Sensors	17
Exhaust Gas Temperature Sensors (EGT)	17
Position Sensors	18
ST 749 Hydraulic Pressure Sensors	20
ST8996 CAN ECU Interface	21
Lap Timing System	21
Wiring harness	25
Chapter 4. Display Panel	27
Peak Values (Tell Tales)	27
Alarms	28
Chapter 5. Using the Multi-Function Dash-Logger	29
Configuring the system	29
Checks and Alarms	30
Lap times	30
Recording Data (Data Logging)	30

ensure that the goods are adequately packaged and insured for the journey.

To arrange for your equipment to be returned for an initial inspection, please contact your dealer. The process for returning goods is as follows:

1. Contact the dealer from whom you purchased the goods.
2. Your dealer will complete and send you a Returns Authorisation form by fax or mail. This form includes a unique Returns Authorisation Number (RAN).
3. You must include that form with the goods when shipped. Your dealer will be able to advise you on the shipping of your goods.
4. At the time of shipping your goods you should arrange to make payment via your dealer for the initial inspection. Your dealer will advise you of this fee.

Your goods will then be returned to Stack’s factory in the UK. The inspection and service process is explained below:

1. On receipt of your goods they will undergo the initial inspection by one of our engineers.
2. Our engineers will attempt to reproduce the fault as reported and an assessment will be made with regards the complexity of the corrective action:
 - i) If the corrective action can be identified at this stage, we will contact you with details of the repair work required, as well as a quotation for that work.
 - ii) If corrective action cannot be easily identified at this stage, a full diagnosis and a “Corrective Action Assessment” will be conducted. Using this information we can then contact you and advise on the next course of action and will quote on expected duration and cost of repairs where applicable.
3. Once we have received your authorisation to proceed with any repair work required, we will complete the work and request payment. A full final test will be conducted before the goods are packed ready for shipping.

When contacting your Dealer with a Technical Support or Service enquiry it is important that you have to hand the following information:

- Serial Number (found on the rear of the product).
- The Model Number.
- The date of purchase.
- A copy of the packing list supplied with the product.
- If it is a Data Logging product, please provide the TAG number and the software licence number. Your Dealer will be able to advise you if you need help locating those numbers.

This information will help your Dealer ensure that your enquiry is handled and processed in an efficient manner.

Service Enquiries

If you or your Dealer have identified a fault with your Stack equipment, it is possible to return the goods for inspection. Your Dealer will help you with this. Before you return your equipment, please be aware that:

- All services and repairs are subject to an initial inspection. No commitment can be made to repair the goods in full or within a specified budget or timescale until this inspection has been completed.
- An initial inspection fee will be charged for all services. Payment will be required before we conduct the inspection. On completion of the inspection you will be advised of any work and costs involved in repairing the goods. At this point you will have the choice to proceed with or terminate this service.
- It is your responsibility to safely ship (at your expense) the goods to Stack. It is also your responsibility to arrange for the safe return of the goods, unless the goods have been repaired under warranty, in which case Stack will organise for the safe return of these goods. Please

Calibrating Sensors	31
Chapter 6. System Specifications.....	33
Appendix A. Display Module Template	35
Appendix B. Wiring Harness Diagram	37
Appendix C. Switch Functions	38
Appendix D. Light Functions	38
Appendix E. Service and Support	39
Stack Web-site.....	39
Contacting your Dealer	39
Service Enquiries	40
Stack Contact Details	43
Index	44

Appendix E. Service and Support

At Stack we pride ourselves on having, not only a very highquality engineered product range, we also strive to offer a first class service when it comes to supporting our customers and installed product base.

Stack Web-site

If you have a question about a Stack product or if you are experiencing a problem, we have made a wealth of information available on our web-sites where you can find the answers you need.

International

www.stackltd.com

United States

www.stackinc.com

Frequently Asked Questions

Log-on to the Stack web-site, click on Motorsport Division and then the Support tab at the top of the home page. Then click on the FAQ Page item.

If you need a User Guide click on the Manuals and Download Support Area item. You will be asked to submit some basic information for Stack's internal use but, once submitted, you will have immediate access to downloadable versions of our product manuals. These manuals will give clear instructions on the installation and correct operation of your Stack product as well as including useful Troubleshooting sections.

If you still have unanswered questions, please contact the Dealer from whom you purchased the product.

Contacting your Dealer

For a current list of dealers, log-on to the Stack web-site, click on Motorsport Division and then the Where to buy tab at the top of the home page and select the Distributors menu item.

Appendix C. Switch Functions

Functions	Switch
Show Peak Values	1
Clear Alarms or Change Display Layer	2
Manual Lap Marker	3
Display Stack software version banner	1 & 2
Reset lap times and reset peak values	1 & 3

Appendix D. Light Functions

Functions	Light
Alarm active on display	Warning light
Engine speed above shift set-point	Shift light

Chapter 1. Introducing the Multi-Function Dash-Logger

The Stack ST8916 Multi-Function Dash-Logger (MFD) can monitor a range of values, known as performance parameters, needed for effective car and driver management in most competitive situations.

The system consists of a nine-input sensor module with a built-in 32 megabyte data recorder.

The system also provides a gearshift warning light that illuminates above an RPM value that you define for your vehicle.

All of the sensors may be recorded at rates up to 200 samples per second (200 Hz). Data recording can be configured to start when a parameter, eg, Engine Speed, rises above a preset value.

The recorder can hold thirty Runs and those runs can be downloaded to you PC using the Stack DataPro software (see separate Users Guide).

How to use this Manual

Stack recommends that you unpack and connect the components in the system before you install it in your vehicle. This will enable you to familiarise yourself with operating the system and configuring it for the vehicle in which you intend to install it.

This manual starts by taking you through the process of checking the system before installation, installing it in your vehicle, configuring the system and finally using it.

! *This manual does not attempt to explain how to interpret or use the information from the ST8916 Multi-Function Dash-Logger as this is very specific to the type of vehicle in which it is installed and the type of competition in which that vehicle is engaged.*

Chapter 2. Getting Started

This chapter guides you through the initial unpacking and setting-up of the equipment for pre-installation checks and familiarisation with its operation.

Standard Multi-Function Dash-Logger Items

The ST8916 Multi-Function Dash-Logger is supplied with the following standard components:

Quantity	Description
1	Multi-Function Dash-Logger Module (ST8916)
1	Wiring Harness (ST872-925)
1	Network Starter Harness (ST877)
1	ECU Engine Speed Extender (ST918024-101)
3	Peak, Layer & Lap Switches (ST511)
1	CAN-USB Network Interface (ST8990)
3	Internal G Sensors
1	Proximity Sensor (Wheel Speed) (ST670)
1	ST543 Lap Timing Sensor
2	0.7 metre (27 inch) harness extenders
2	1.4 metre (55 inch) harness extenders
2	2.1 metre (82 inch) harness extenders
1	DataPro Software (ST920033)
1	DataPro Quick-start Guide (ST542095)
1	Designer Quick-start Guide (ST542068)

Optional Items

Quantity	Description
1 or	Multi-Stage Gear Shift Warning Light (ST539) or Single Gear Shift Warning Light (ST534 or ST537) and (ST918081) adapter cable
1	Infra-red Lap Timing Beacon (ST544)
1	Alarm Light (ST536)
1	CAN ECU Interface Option (ST8996)

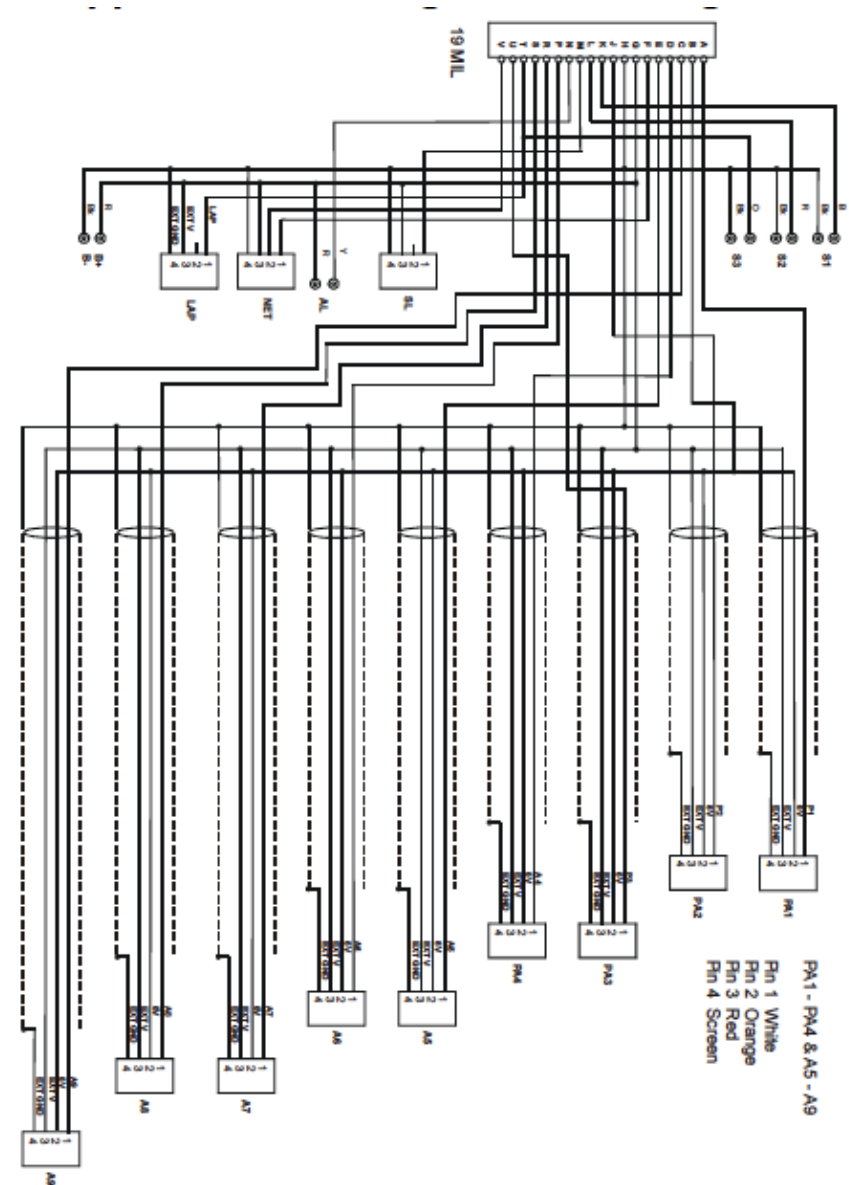

Various Sensors	to suit your needs
-----------------	--------------------

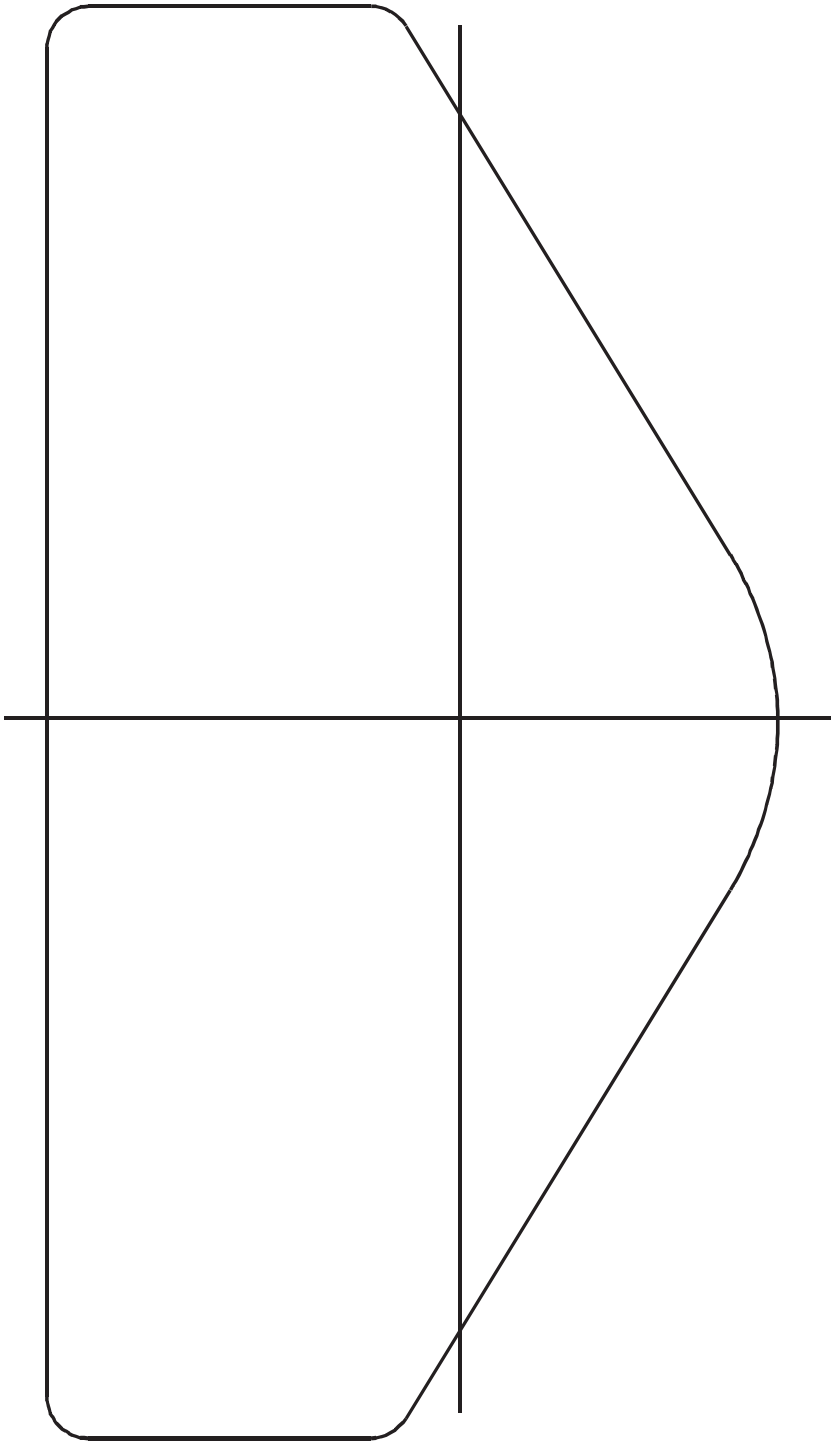

5. Fuel level.

The fuel level alarm is indicated by a separate warning light; the unit does not display any message for the fuel level alarm.

6. Battery voltage

When the warning condition alarm light is switched on, a warning message is shown on the digital display to identify the condition. You can enable or disable the warning system for each parameter individually.

You can cancel the warning message by pressing a switch. Doing this does not turn off the warning condition alarm light, which stays on until the condition no longer applies.

You can redefine the preset alarm values for each parameter to those which are more suitable for your vehicle.

The system provides outputs for two external warning lights:

- a gear shift warning light that is based on an RPM value that you define for your vehicle
- an additional alarm warning light for the alarms described above

Either model can also be fitted with an optional lap timing sensor.

ST8130 Models

Standard ST670 wheel speed sensor. This system obtains the vehicle speed from the rotations of one of the wheels on the vehicle.

Optional ST492 pulse amplifier. This system obtains the vehicle's speed from pulses generated by the vehicle's original equipment gearbox or transmission sensor.

Appendix A. Display Module Template

Use the template on the following page for cutting out an aperture for the Display Module.

Lap Marker inputs (LAP)

Description	Value	Units & Notes
I/p Impedance	5.0 \pm 0.5	kOhms (to +5v)
Negative edge threshold	2.5 \pm 0.5	Volts
Input over-voltage range	-2 to +18	Volts min/ max
High period pulse width	5	mS Min
Low period pulse width	5 mS	Min
Lap Marker blanking period	10	Seconds min

Battery power input (B+ & B-)

Description	Value	Units & Notes
Input voltage operating (B+ & B-)	9 to +18	Volts min/ max
Input over-voltage range	-20 to +25	Volts min/ max
Supply current	0.3 to 1.0	Amps typical – Max (fuse at 5A)

How to use this Manual

Stack recommends that you unpack and connect the components in the system before you install it in your vehicle. This will enable you to familiarise yourself with operating the display and configuring it for the vehicle in which you intend to install it.

This manual starts by taking you through the process of setting up the system before installation, operating the digital display, configuring the system, setting the alarm values and installing it in the vehicle. By the end of Chapter 2, you will have set up the system so that you will be assured that it is functioning normally. You can then read Chapter 3 and practice using its functions. Chapter 4 takes you through configuring it for your vehicle. Chapter 5 explains how to install it in the vehicle. Chapter 6 provides a set of troubleshooting guidelines.

A full size template for the dashboard cut-out for the ST8130 systems is provided in Appendix A along with a dimensional drawing on page 33. There is a schematic diagram of the wiring harness in Appendix B.

The Multi-Function Dash-Logger Module

The Multi-Function Dash-Logger Module consists of a compact display module which incorporates an analogue tachometer, an LCD Display and warning lights. That module is connected to up to nine external sensors by a wiring harness with a 19-way military connector. The wiring harness also allows connection to a PC for configuration and downloading recorded data.

Wiring Harness

Each of the wires in the harness is labelled:-

Label	Connection to
AL	Alarm light
SL	Gear shift light
S1, S2 and S3	Peak, Layer and Lap Switches
LAP	Optional Lap timing sensor
PA1	Engine speed (RPM) or 5 volt sensor
PA2 to PA4	Pulse or 5 volt sensors
A5 to A9	5 volt sensors
NET	CAN-USB connection to PC
B+	Battery positive (9 – 18 volts)
B-	Battery negative (Earth)

Chapter 6. System Specifications

Power supply	9 to 18 Volts DC @ 0.3A typically 1 Amp max (fuse @ 5A)
Working temperature	-20 to +70 Degrees Celsius (-4 to 160 Degrees Fahrenheit)
Size	200 mm x 105 mm x 50 mm (8" x 4¼" x 2")
Weight	0.5 kg (1.1 LB)
Vibration	30 G, 50 to 2000 Hz, 1 Octave / min, 36 Hours
Humidity	0 to 100% condensing (Fully sealed)
Immersion	IP67

Analogue sensor inputs

Input Description	Value	Units & Notes
Input impedance	>1.0	MOhms (to +6.25v)
Input voltage measurement range	0 to +5.0	Volts min max
Input over-voltage range	-2 to +18	Volts min/max
Input resolution	10bit (~5mV)	0-1023

Pulse sensor inputs

Input Description	Value	Units & Notes
Input pull-up	18	mA (to +6.25v)
Input edge threshold	5.5 ±0.5	Volts Note: Note: Add 390R in series for 2.25v
Input over-voltage range	-2 to +18	Volts min/max
Max input frequency	2.5	KHz
High period pulse width	0.1	mS Min
Low period pulse width	0.1	mS Min

Pulse sensor outputs (S5V)

Output Description	Value	Units & Notes
Sensor 5v supply voltage	5.00 ±0.05	Volts
Sensor 5v supply current	100.0	mA max

The Display Module

The Display Module consists of an analogue tachometer, a digital display panel and two warning lamps.

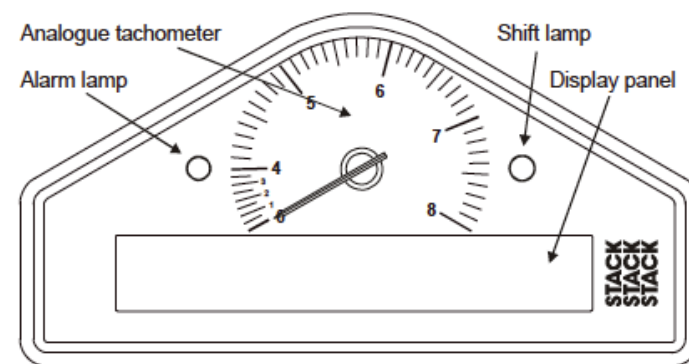

Front View

The Display Module is connected to a variety of sensors by a wiring harness. The wiring harness has a 19-way military connector for connection to the Display Module.

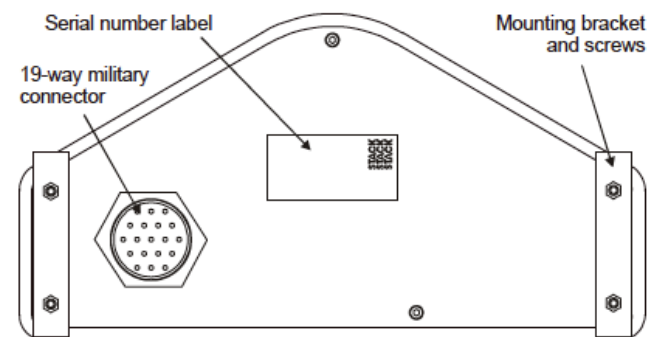

Rear View

Connecting the Components

Refer to the diagram below which shows the wiring for the Multi-Function Dash-Logger:-

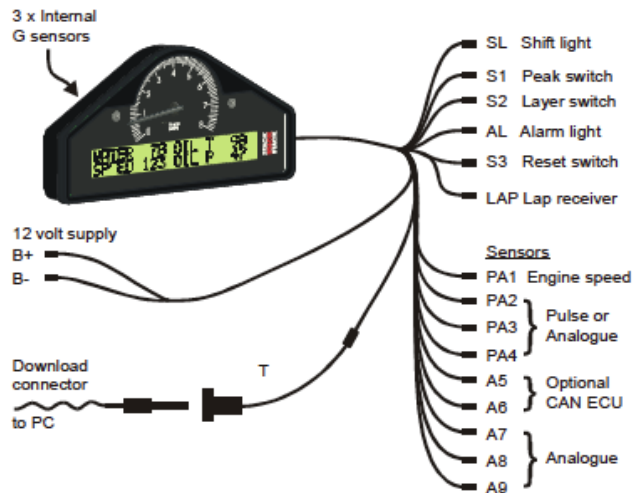

1. Connect the Wiring Harness to the Multi-Function Dash-Logger Module.
2. Connect the three switches to the wires labelled S1, S2 and S3.
3. Connect the Alarm Light to the wire labelled AL.
4. Connect the optional Multi-stage Shift Light or Single Shift Light to the wire labelled SL.
5. Connect the optional CAN ECU adaptor harness to A5 and A6.
6. Connect each of the sensors that you have purchased to the appropriate wire in the wiring harness. The first four sensor connections (PA1 to PA4) can handle either Pulse or Analogue (5 volt) sensors. The remaining five connections (A5 to A9) can only handle Analogue sensors.
7. Connect a 12v DC power supply to the power inputs, eg, from a car battery. B+ is battery positive and B- is battery negative. Protect the B+ line with a 5 amp fuse.

that is required to perform the download is to plug the jack into the on-vehicle socket. Data will be transferred to the PC immediately the connection is made.

! For further details please refer to the Stack DataPro documentation.

Calibrating Sensors

Certain sensors should be calibrated so that their recorded data is displayed correctly once downloaded to DataPro. The following parameters are the most common types which need to be calibrated:

Parameter	Calibration
Wheel speed	Set the Wheel Circumference to the overall measurement of the sensing wheel
G sensors	Set the zero point for each G sensor with the race-ready vehicle standing on a level surface
Suspension sensors	Set the zero point for each suspension sensor with the raceready vehicle standing on a level surface
Pedal positions: Throttle, Brake etc	Set the values for resting and fully depressed pedal positions
Steering position	Set the 90° left and 90° right steering wheel positions

! For further details please refer to the Stack DataPro Designer documentation.

Checks and Alarms

You should check the system to ensure that all the sensors are detecting the correct values. This is most easily accomplished using DataPro's Data Monitor function. You should run the engine up to its operational levels to check that the values displayed are accurate.

Lap times

Lap times are recorded whenever they are triggered by the optional infra-red lap timing system or when the driver presses the Lap Switch. If the LCD Display has been configured for it, a lap time will pop up when either of those situations occur.

The lap times will be available to view in DataPro when the recorded data has been down-loaded to your PC.

Recording Data (Data Logging)

Recording can be set using DataPro Designer to start automatically when the Engine Speed exceeds a pre-defined RPM. The Multi-Function Dash-Logger records channels at the rates chosen in Designer. When setting the recording rates Designer indicates the maximum amount of recording time which is possible with those rates.

A message will pop-up on the LCD Display when ever recording starts or stops.

The ST8916 Multi-Function Dash-Logger can record up to 30 runs of data. No more recording is allowed if the memory is full or the maximum number of runs is reached.

Once data has been recorded it can be downloaded to your PC using DataPro's Recorder features. Connect the Multi-Function Dash-Logger to your PC using the Stack CAN-USB interface cable. Connect it to the PC via the USB connector and to the vehicle using the 4-way jack plug.

It is possible to put DataPro into download mode prior to the car being available, eg, before it arrives at the pits. Then all

8. Switch on the 12v DC power supply.
You can now proceed to familiarise yourself with operating the Multi-Function Dash-Logger

Chapter 3. Installing the Multi-Function Dash-Logger

This chapter guides you through installing the system in your vehicle.

Who can install the Multi-Function Dash-Logger?

The Multi-Function Dash-Logger can be installed by anyone competent in fitting electrical and mechanical accessories to cars.

Tools needed

No special tools other than normal workshop tools are required.

Fitting the Multi-Function Dash-Logger Module

The Display Module is fitted into a cut-out in the instrument panel/dashboard and secured using the two U-brackets at the rear. The dimensions for the cut-out are shown below. A full-size template can be found in Appendix A.

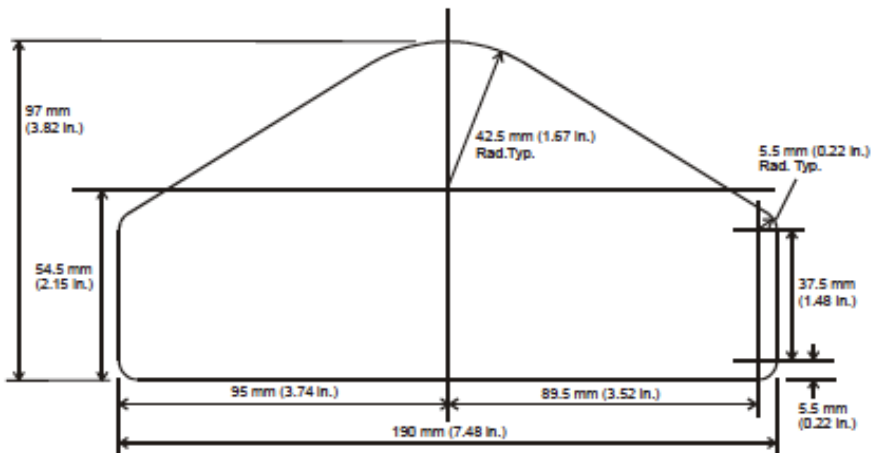

Chapter 5. Using the Multi-Function Dash-Logger

Configuring the system

Before using the Multi-Function Dash-Logger it must be configured to work with the sensors and optional parts you have installed. This is performed using the DataPro Designer program.

There is no limit to the number of times configurations can be uploaded into the Multi-Function Dash-Logger. So, as your system changes over time, perhaps by adding new sensors, changing the recording rates of existing sensors or modifying the layout of the LCD Display, new configurations can be created. This makes the Multi-Function Dash-Logger a very powerful tool since it is so easy to adapt it to new environments.

Details of how to install the DataPro suite of software and how to use Designer to configure your Multi-Function Dash-Logger is described in separate User Guides supplied with your system.

Configuration Memory

The uploaded configuration is stored in non-volatile memory so it is retained when the external power source is disconnected from the system.

If, after several years, the configuration (and any recorded data) is lost when the system is powered down, it is likely that the internal back-up battery will need replacing. In that case the Multi-Function Dash-Logger Module should be returned to Stack for a service during which its internal battery will be changed.

! Ideally the modules should be returned every 4-5 years to ensure no loss of data.

To reset the peak values:

- Press and hold the Peak Switch to display the peak values.
- While holding that switch, press and hold the Lap Switch.
- With the Lap Switch held down, you will see the parameters revert to the current values. The new peak values that are stored are those being displayed when you release the Lap Switch.

Alarms

The Multi-Function Dash-Logger has the ability to show warnings and alarms to alert the driver when certain parameters either exceed or fall below their alarm values. For example, a warning may be issued if the fuel pressure falls below its alarm value or if the oil temperature rises above its alarm value. You can adjust the preset alarm levels when you configure the Multi-Function Dash-Logger using DataPro Designer.

You can configure the warnings so they are triggered only while another parameter is above or below a defined value, eg, while the engine speed exceeds a certain RPM. Blipping the engine should not be enough to trigger a warning. This helps to prevent abnormal warnings from being triggered when, for example, the engine is either not running, is idling or is being warmed up.

Displaying an Alarm

When an alarm condition occurs, the built-in red warning light turns on and a pop-up message is displayed. The optional external light will also illuminate.

Clearing an Alarm

Press the Layer Switch while an alarm is being displayed to clear that alarm.

Positioning the Display Module

Ensure that there is sufficient space behind the cut-out to allow the wiring harness to be connected to the 19-way connector without any tight bends to the wiring near the connector.

The Display Module must be positioned on the dashboard so that the driver can see it, either over the steering wheel or through it.

In order to get the most accurate results from the internal G sensors, the Display Module should be aligned so that it is as close as possible to the three main axes (X, Y and Z) of the vehicle. The DataPro Designer Calibration function allows any minor out-of-axis errors to be corrected but it cannot be used to correct alignment errors of more than 5 degrees.

Switches

The three switches are used to control the functions of the Dash-Logger.

The normal functions of the switches are:

Switch	Function
1	Show Peak Values
2	Clear Alarms or Change Display Layer
3	Manual Lap Marker
1 & 2	Display Stack software version banner
1 & 3	Reset lap times and reset peak values

You can install the switches in any convenient location. When installing the switches, you should take account of the following considerations:

- The cable for each switch is approximately 400 mm (16") in length from the 19-way military connector so use extender cables if necessary.
- It is important that the driver can reach the Peak and Layer Switches easily in order to show peak values and

to clear alarms. These switches would normally be fitted on or near the steering wheel.

- If the driver is also going to enter lap markers manually, the Lap Switch should ideally be fitted on the steering wheel.
- Drill a 13 mm (0.5") in a suitable panel or manufacture a bracket with a hole in it.
- Insert each switch from the reverse side of the panel and screw on the rubber cover from the front. Do not overtighten the nut; just greater than hand-tight should be enough.

Warning lights

The Display Module has two built-in warning lights. One of these is for the gear shift light and the other for warning the driver that an alarm has been triggered.

As an option, you can install an additional external warning light which should be mounted in any position that is in the driver's direct line of vision as it needs to be visible at all times.

Stack can supply suitable external warning lights for installation in the dashboard as well as shrouded versions that can be mounted on top of the dashboard.

- Drill a 13 mm (0.5") in a suitable panel or manufacture a bracket with a hole in it.
- Pass the light through the hole from the viewing side.
- Thread the plastic nut over the two wires and tighten it on to the light. Do not over-tighten the nut; just greater than hand-tight should be enough.
- Connect the wires to the AL cable on the wiring harness using an extension cable if necessary.

! *If you are using your own warning light, ensure that the bulb rating does not exceed 2 Watts otherwise the Multi-Function Dash-Logger Module will be damaged.*

Chapter 4. Display Panel

The built-in Display Panel has been designed for presenting driver information in as clear and precise way possible.

Simple controls allow the display to be scrolled through six display layers by pressing the Layer Switch. Each layer can show either 2, 4, or 6 parameters.

During alarm conditions the whole display is used to present a warning message and its associated alarm value.

Peak Values (Tell Tales)

The Multi-Function Dash-Logger System can display the peak values (sometimes called 'tell-tales') that have been recorded during a run for all the displayed parameters.

Peak values are updated only when the engine speed has exceeded its fixed 'gate value' of 3000 RPM for at least one second which allows the values to stabilise. Blipping the engine may not be enough to update the peak values. This is to prevent abnormal peak values from being recorded when, for example, the engine is either not running, is idling or is being warmed up.

Displaying the Peak Values

Press and hold the Peak Switch to show the peak values for the parameters currently being displayed. Release the switch to return to the normal display.

Resetting the Peak Values

You can reset all of the peak values manually. If the engine is running at or above its gate RPM when the peak values are reset, they are set to the current value of each performance parameter.

If the engine is running below its gate value, the peak values are not reset to the current values but are set to full-scale values appropriate for the type of peak which has been chosen.

! Particular care is needed when passing wires through holes in carbon fibre as the carbon can cut through cables very easily.

- The download jack socket (the NET connector) should be mounted to the vehicle through a 25.4 mm (1") diameter hole. It should be positioned so that it is easily accessible to the PC for downloading data when the vehicle comes into the pits. Packing washers are provided to ensure the socket is securely mounted.
- Connect the wires when all the sensors are in position and you have secured the wiring harness.

Mini Sure-Seal Connectors

The Multi-Function Dash-Logger Module connects to its sensors via four way ITT Cannon Mini Sure-Seal (MSS) connectors. A plug (the smaller of the two connectors) can be found on the ends of the Sensor Harness and a receptacle on the cable from the sensor. The following polarity is observed in all cases:

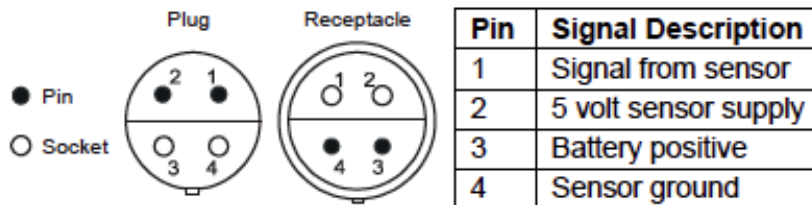

! Mini Sure seal connectors offer excellent vibration and waterproof performance. However they do not have a positive locking mechanism so must not be subject to bending or pulling load, as such loads can cause the connector to fail.

External Shift Lights (optional)

In addition to the internal shift light, the Multi-Function Dash-Logger Module has the ability to illuminate an external light to indicate it is time to change up a gear. The gear shift light illuminates when the engine RPM exceeds a predefined values.

Two types of gear shift lights may be fitted as described below.

Single Shift Light

The Single Shift Light which, when illuminated, indicates that it is time to change up a gear.

The light should be installed in a position so that it is visible to the driver while seated in the car.

- Drill a half inch (12.7 mm) hole in a suitable panel or manufacture a bracket with a hole in it.
- Pass the light through the hole from the viewing side.
- Thread the plastic nut over the two wires and tighten it on to the light. Do not over-tighten the nut; just greater than hand-tight should be enough.
- Connect the wires to the SL cable on the wiring harness using the adapter harness supplied with the light.

! If you are using your own warning light, ensure that the bulb rating does not exceed 2 Watts otherwise the Multi-Function Dash-Logger Module will be damaged.

ST539 Multi-Stage Shift Light Module

This module contains five high-brightness LEDs which illuminate in turn as the engine RPM increases. The setpoints for each LED are configured using DataPro Designer (see separate User Guide).

- Site the Multi-Stage Shift Light Module in front of the driver so that the LEDs can be seen while seated in the car.
- Mount it using the Dual Lock™ tape supplied or use the M3 tapped holes (10 mm maximum depth) in the body of the Shift Light Module.
- If you wish to take advantage of the night-time illumination level, mount the push-button Dimmer Switch within easy reach of the driver. Pressing that switch toggles between pre-set high and low brightness levels.
- Identify the 'SL' wire on the Sensor Harness. Connect the mini sure-seal connector on the shift light harness to this wire.

Engine Speed (RPM) Measurement

The engine speed (RPM) is measured by connecting the engine speed wire directly to the ignition system. A single wire from the connector labelled PA1 connects the Multi-Function Dash-Logger to the ignition system.

- ! *The PA1 input has special properties which will reject noisy signals making it ideal for connecting to engine speed signals, particularly signals obtained from magnetos. For this reason Engine speed signals should not be connected to PA2 to PA4.*

Connecting the Multi-Function Dash-Logger to the ignition system

The Multi-Function Dash-Logger can be connected to engines with a variety of ignition systems as shown in the table below:

Wiring harness

The Multi-Function Dash-Logger Module and the sensors, switches and lights are connected together by means of the wiring harness and sensor extender cables supplied with the system or the sensors.

The wiring harness can be fitted after the Multi-Function Dash-Logger Module and all the sensors and switches have been installed.

The sensor harnesses have short cables terminated with Mini Sure-Seal connectors. Likewise the sensors have short cables terminated with the mating connector. Since neither of those short cables is likely to be long enough to reach the sensors in their installed positions, you will need to bridge the gap using extender cables which are available from your dealer in a variety of lengths.

Fitting the wiring harness

When fitting the harness on the vehicle, you should observe the following:

- Start by attaching the sensor harness to the Multi-Function Dash-Logger Module by connecting the 19-way military connector.
- First position the ends of all the wires at the locations of the sensors, lights and switches to which each is to be connected, but do not connect them yet.
- All wires should be as far as possible and not less than 75 mm (3 inches) from sources of heat and electrical noise such as exhaust pipes, ignition HT leads, distributor caps etc.
- When you pass any wire through a bulkhead or dashboard, fit a cable gland into the hole so that the edge of the hole cannot chafe the wire.

- Avoid positioning it so that the sun is directly behind it when it is being used.
- Where the unit is to be used for lengthy periods in very hot or sunny conditions, it should be protected by shading it from direct sunlight.
- Do not allow water to be sprayed onto the transmitter lenses. During wet conditions fit a protective peak over the beacon.

- ! To prevent distortion of the coded infra-red signal, do not cover the beacon with a plastic bag.

Power supply to trackside beacon

The trackside beacon operates from a 12 volt DC supply. A sealed lead-acid battery with a minimum rating of 2.5 Amp/hour is recommended. This will provide about 15 hours of operation.

The condition of the battery is indicated by the colour of the LED indicator on the front panel of the unit:

Green	The voltage is, at present, adequate for use
Red	The voltage is too low (replace or charge the battery).
No colour	The battery is exhausted or disconnected.

Ignition System	Connection Point
ECU	Direct to tachometer output
Coil and Points	Use adapter (ST493) to connect to the coil negative (low tension) terminal
HT coil lead	Use HT pick-up (ST697)

The following connections are shown in greater detail:

- Electronic ignition or ECU connection
- Standard contact breaker system
- Contact breaker series resistor connection

Electronic Ignition or ECU Connection

Connect the PA1 wire directly to the "Tacho" output of the electronic ignition or Engine Control Unit.

The signal can be either a 5 volt or 12 volt pulse.

Standard contact breaker system

Connect the PA1 wire to the negative terminal on the coil using a ST493 ESPD Interface cable.

- ! Do not connect the PA1 cable directly to the coil or the Multi-Function Dash-Logger Module will be damaged.

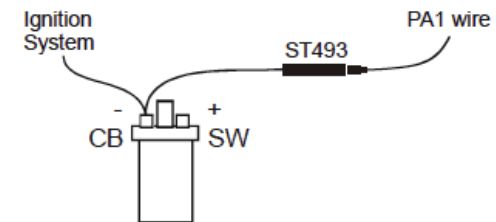

- ! Ensure the ignition system wire is held away from the ST493
- wiring for greater than 100 mm (4 inches).

Wheel speed and transmission sensors

The Multi-Function Dash-Logger can be connected to a range of proximity sensors to measure, for instance, wheel or transmission speeds. These sensors are used to measure wheel or shaft rotation in order to display the speed in MPH or RPM. The sensor provides an electrical pulse to the system each time a ferrous object, such as a CV joint bolt, passes near to the end of the sensor. When configuring the system you need to supply the number of ferrous objects that will be counted for each revolution. In addition for speed you must supply the circumference of the wheel using Designer's Calibration facility.

Fitting proximity sensors

These sensors are triggered by a number of 'Targets' (see *Sensor Targets*). It is essential that these devices and their cables are positioned as far as possible from all sources of intense heat and from the ignition HT leads to avoid interference.

Sensor targets

The targets can be any suitable metallic object which passes within range of the sensor tip. Iron and mild steel targets are preferred as they give the strongest signal to the sensor. Aluminium, brass and copper targets give approximately one third of the sensing range which makes setting up the sensor difficult and may cause the speed signal to be unreliable.

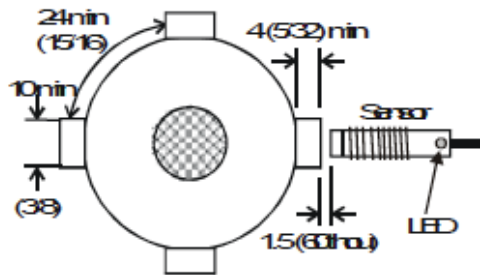

- ! After detecting a signal from a beacon, the system does not recognise any further signals for a period of ten seconds. This is to prevent multiple lap times being recorded if there is more than one Stack beacon positioned along the pit wall.

ST544 Trackside Infra-Red Lap Beacon

The trackside infra-red lap beacon works with the ST543 lap timing sensor to trigger the Multi-Function Dash-Logger to record a lap time.

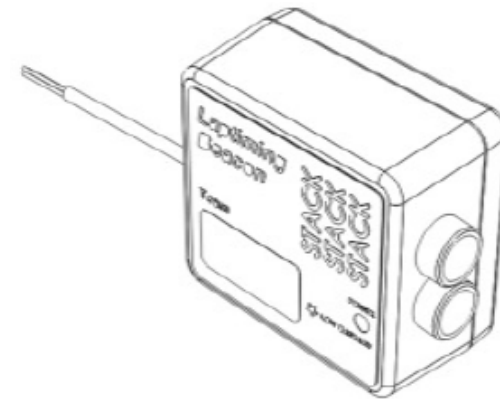

The housing has a threaded socket on its base for mounting to a standard photographic tripod. It should be located as follows:

- As near to the start-finish line as possible. A feature of DataPro allows the offset between the beacon and the start line to be adjusted.
- At the same height as the on-vehicle infra-red sensor.
- Level so that it emits a horizontal beam.
- It must be between 2 and 30 metres (6 to 100 ft) from the vehicle when the vehicle passes it.

- A Lap Timing Sensor (ST543) which is fitted to your vehicle and responds to a coded infra-red signal.
- A Trakside Beacon (ST544) which transmits an infrared beam to activate the lap timing sensor.

ST543 Lap Timing Sensor

The lap timing sensor is actuated by an infra-red beacon positioned at the side of the track. The sensor is fixed to a rigid bracket mounted at a convenient position on the outside of the vehicle where it is able to detect the signals from the beacon.

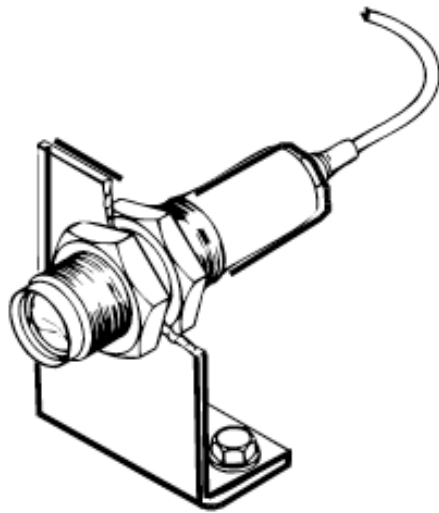

- It is secured through a 18mm (0.7") diameter hole by two nuts with M18 x 1mm threads.
- This sensor must be positioned horizontally and square to the axis of the vehicle.
- In order to detect the signals from the beacon it must be situated outside the vehicle.
- It should, if possible, be positioned so that other vehicles that are being overtaken (or are overtaking) at the moment your vehicle passes the beacon do not block the signal.

It is important that the sensor and targets are rigidly mounted so they do not move with vibration. The sensor bracket should have a suitable hole for the threaded portion of the sensor to pass through. Targets should be at least 10 mm (5/8") across and stand 4 mm (5/32") proud (Fig.1). Smaller targets can be used but these will reduce the range. Small aluminium, brass or copper targets will generally not work. Nothing except the targets should come within 6 mm (1/4") of the end of the sensor. If the sensor mounting position is to be recessed, a hollow of 24 mm (15/16") diameter and at least 4 mm (5/32") deep should be allowed around the sensor.

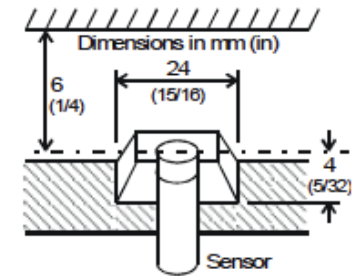

Sensor fitting and adjustment

1. Connect the Mini Sure-Seal connector of the proximity sensor to the system via PA1 to PA4 of the Sensor Harness. Turn on the power.
2. Assemble the first (rear) nut onto the sensor.
3. Insert the sensor into the mounting bracket hole and fit the front nut.
4. Rotate the wheel or shaft and move the sensor slowly forward by undoing the rear nut counter-clockwise until the built-in light (LED) comes on for every target. That light is used to check that both the mechanical and electrical installations have been performed correctly. This light should be ON when a target is in front of the sensor.
5. Undo the rear nut half a turn more.
6. Without rotating the sensor or rear nut, finger-tighten the front nut.
7. Tighten the rear nut with a 13 mm AF spanner. Do NOT let the sensor rotate.

- ! Do not over-tighten; one flat of the nut should be sufficient. A small amount of silicone sealer will prevent it vibrating loose.

Checks for correct installation and adjustment

- Rotate the wheel or shaft and check that the built-in sensor light comes on for each target and goes off between each target.
- Check that both the sensor and targets are rigidly mounted.
- Check that the front nut or any fixings do not cover any part of the sensing end.

- ! Check the gap between sensor and any of the targets is NOT less than 0.5 mm (3/16") so there is no risk of the sensor hitting the targets.

Fluid Pressure Sensors

The Multi-Function Dash-Logger can be connected to a range of fluid pressure sensors to measure, for instance, Oil Pressure and Fuel Pressure.



Fitting the pressure sensors

- Position the sensors and their cables as far as possible from all sources of intense heat and from the ignition HT leads.
- Each sensor can either be screwed in directly to the monitoring point or fitted separately by using a suitable pressure hose to connect it to the monitoring point.
- Do not screw the sensor directly into the engine block because excessive vibration from some racing engines can affect the long-term life of the sensor.

- Ensure the sensor is mounted at a low point with its opening upwards to allow trapped air to be removed during the brake bleeding process.

ST8996 CAN ECU Interface

The CAN ECU Interface is used to connect the Multi-Function Dash-Logger to an Engine Control Unit. With this interface it is possible to get parameters directly from the ECU saving the time and effort of fitting separate sensors.



Connect the harness by following these guidelines.

- The CAN Adaptor Harness must be connected to both analogue inputs A5 and A6.
- The green and white wires must be connected to CAN Lo and CAN Hi respectively on the CAN output of the ECU.

- ! It is common for the CAN Hi and CAN Lo connections to be identified incorrectly. If no signal can be seen, it may just need the green and white wires to be swapped.

- The CAN terminator should be installed only if there is no terminator within the ECU.

- ! To determine if the terminator is required, measure the resistance between CAN Hi and CAN Lo. No resistance needs the terminator and a resistance of 120 Ohms requires no terminator.

- Finally configure the Multi-Function Dash-Logger for the CAN ECU interface using DataPro Designer.

Lap Timing System

The Lap Timing system consists of two parts:-

2. Once the intended location for fixing is determined, drill 5 mm (3/16") holes and fit suitable bolts.
3. Attach the sensor body to the chassis and the extending arm to the suspension.
4. Connect the sensor cable to the wiring harness.

! *The spherical bearings at each end of the sensor are designed to absorb any bending forces on the sensor rod and should not be restricted in any way. Failure to do this will result in bending forces being applied which will cause the sensor to fail.*

! *The sensor will be damaged if it is allowed to extend or compress beyond its normal range of movements.*

ST 749 Hydraulic Pressure Sensors

The Multi-Function Dash-Logger can be connected to a range of hydraulic pressure sensors to measure, for instance, Brake Pressure.



Fitting the pressure sensor

! *Reliable braking performance is vital to the safe operation of your vehicle and only a competent mechanic should attempt to fit this sensor. Only high pressure brake line quality fittings should be used.*

- Position the sensor and its cable as far as possible from all sources of intense heat and from the ignition HT leads.
- The sensor has a Dash 3 female thread. Use a suitable adaptor to join it to a three-way connector block inserted into the brake line.

- Do not over-tighten the sensor.
- Plug the sensor's Mini Sure-Seal connector into any of PA1 to PA4 and A5 to A9 of the Sensor Harness.

Fluid Temperature Sensors

The Multi-Function Dash-Logger can be connected to a range of temperature sensors to measure, for instance, Water Temperature and Oil Temperature.



Fitting the temperature sensors

- Position the sensors and their cables as far as possible from sources of intense heat and from the ignition HT leads.
- Mount each temperature sensor directly in the appropriate fluid line. Screw the sensor into a suitable mounting boss so that its tip lies near the middle of the flow of fluid.
- Plug the sensor's Mini Sure-Seal connector into any of PA1 to PA4 and A5 to A9 of the Sensor Harness.

Exhaust Gas Temperature Sensors (EGT)

The Multi-Function Dash-Logger can be connected to a range of K-Type thermocouple sensors to measure, for instance, Exhaust Gas Temperature. These typically measure temperatures from zero up to 200°C (400°F) or 1100°C (2000°F).

Plug the sensor's Mini Sure-Seal connector into any of PA1 to PA4 and A5 to A9 of the Sensor Harness.

Position Sensors

The Multi-Function Dash-Logger can be connected to a range of position sensors for measuring throttle, steering or damper movements.

Plug the sensor's Mini Sure-Seal connectors into any of PA1 to PA4 and A5 to A9 of the Sensor Harness.

ST978 Rotary throttle position sensor

This sensor is designed to be fitted to the end of throttle butterfly shaft. Universal mounting holes are provided to allow the sensor to be bolted on to most standard throttle bodies.

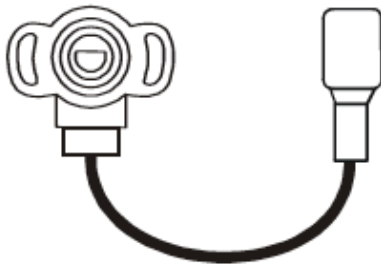

- ⚠ *This sensor is not designed to take radial loads and must be carefully aligned with the centre line of the throttle shaft. Misalignment will shorten the life of the sensor.*

ST979 Rotary position sensor with arm

This sensor has a spring loaded lever which should be attached using a length of stranded wire to, for instance, a throttle pedal.

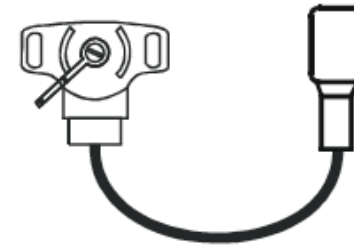

1. Find a mounting position which does not interfere with the drivers feet or operation of the controls.
2. Once the intended location for fixing is determined, drill 4.5 mm (3/16") holes to provide clearance for the supplied bolts
3. Bolt the sensor in place and connect it to the wiring harness
4. Using the length of cable supplied, pass the end of the cable through the hole in the lever arm and attach the other end to the side of the pedal lever.
5. Adjust the cable tension until the lever arm is just pulled away from its resting position. This adjustment should be checked regularly to remove any slack in the cable which may give rise to errors in throttle position.

ST973/9 Linear Displacement Sensors

The linear displacement sensor should be mounted between the vehicle's chassis and a suspension member. These sensors are available with various maximum displacements to suit different suspension systems.

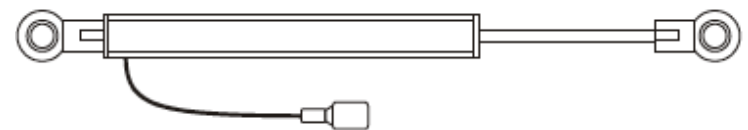

1. Find mounting positions on the suspension members and the adjacent chassis.