



Bugflector® - Bugflector II® - Carflector®

**For proper installation and best possible fit, please read all instructions BEFORE you begin.
For technical assistance or to obtain missing parts, please call Customer Relations at 1-800-241-7219.**

Important Safety Information



- CAUTION - Before driving, ensure that the hood shield is properly secured to vehicle.
- Do not use automatic "brush-style" car washes.
- Do not use cleaning solvents of any kind.
- Periodically check all components for tightness.

Contents

NOTE: Actual product may vary from illustration.



Hood shield



Bump On x4

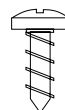

Screw x2



Washer x2



Well Nut x2

Tools Required



Car Wash Supplies



Clean Towel



Phillips Screwdriver

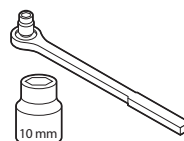

Socket Wrench

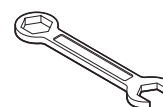

Wrench

Preparation Before Painting / Installation

- A trial fit is recommended to ensure proper positioning and fit.
- Check fit of parts before painting as we will not accept the return of modified or painted parts.
- Wash and dry your vehicle to remove any debris and/or dirt from the installation area.

Installation Steps

NOTE: Actual application may vary slightly from illustrations.

Open hood and locate the hood latch assembly, behind the front grill.

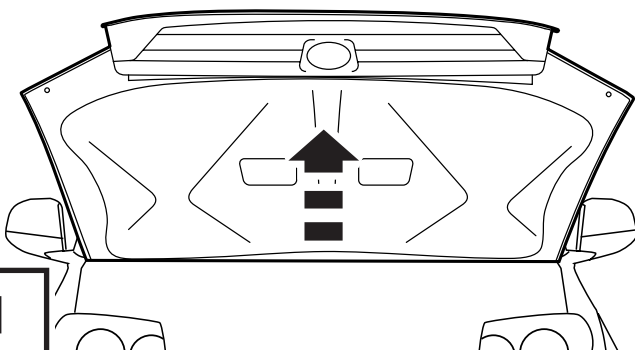

1

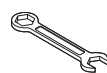

Disconnect the latch assembly from the hood by removing (2) screws with wrench.

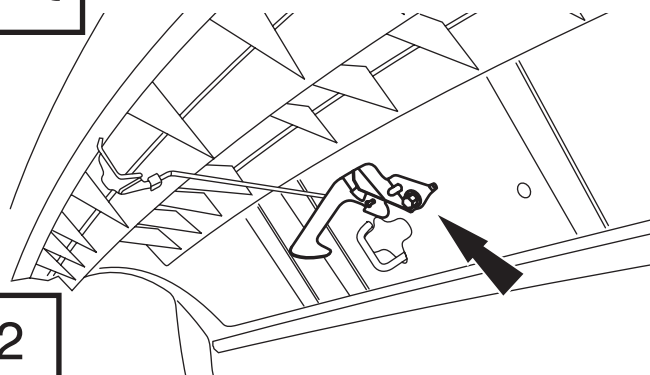

2

Installation Steps

NOTE: Actual application may vary slightly from illustrations.



Locate and remove (8) nuts that secure front grill to the hood. Set grill aside.

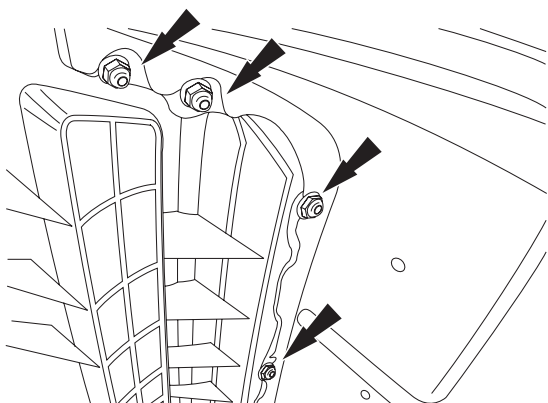

3



Insert (2) well nuts into the existing holes on each side in the underside of hood.

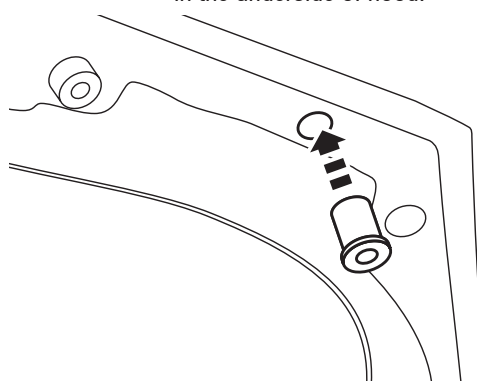

4

Position hood shield onto hood and align hood shield holes with the well nut.

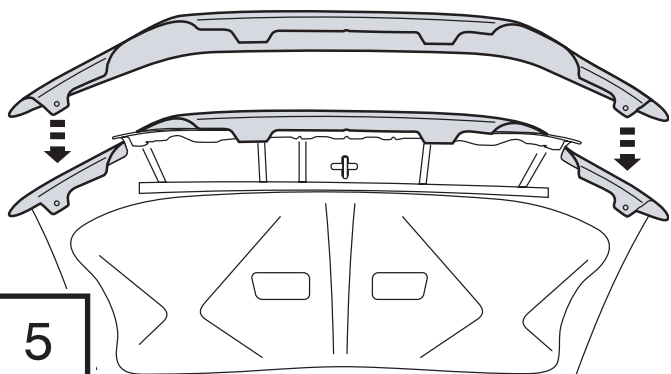

5



Install (1) washer and (1) screw to secure. Tighten until snug. Repeat for opposite side.

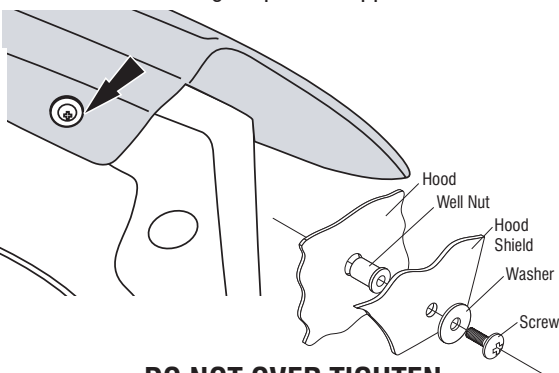

6

DO NOT OVER TIGHTEN

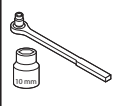

Reattach the front grill by reinstalling the previously removed (8) nuts. Hood shield flange should be between the hood and grill.

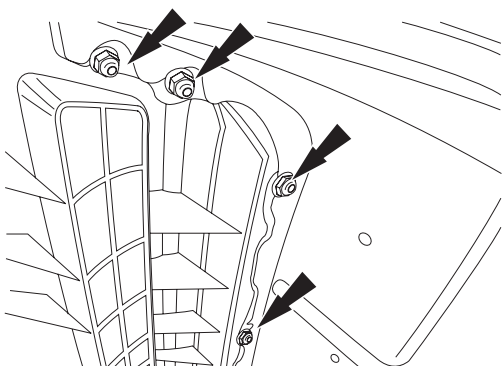

7

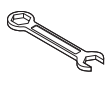

Reattach the hood latch to the underside of the hood by reinstalling the previously removed (2) screws.

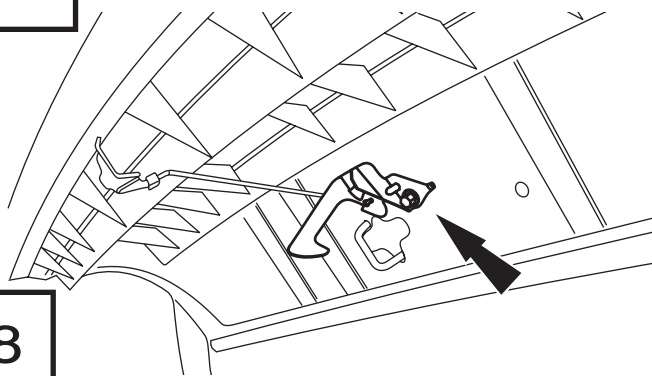

8



Install bump ons at pre-cleaned locations on the hood surface where the hood shield may contact.

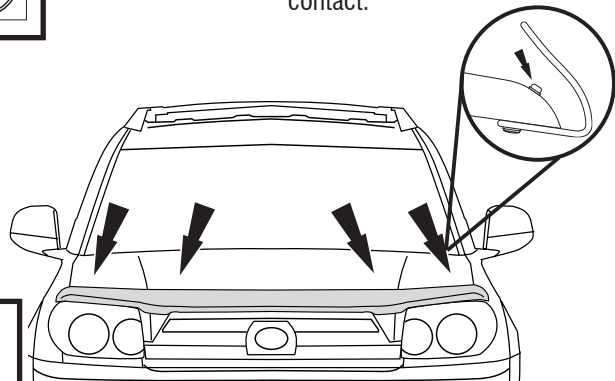

9

Care and Cleaning

- Wash only with mild soap & dry with a clean cloth.

Congratulations!

You have purchased one of the many quality Auto Ventshade™ branded products offered by Lund International, Inc. We take the utmost pride in our products and want you to enjoy years of satisfaction from your investment. We have made every effort to ensure that your product is top quality in terms of fit, durability, finish and ease of installation.



Lund International

800-241-7219 • Visit us at lundinternational.com

© 2012 Lund International, Inc. All rights reserved.



Auto Ventshade™, the Auto Ventshade™ logo and the AVS™ logo are trademarks of Lund International, Inc.





Bugflector® - Bugflector II® - Carflector®

Pour obtenir une installation correcte et le meilleur ajustement possible, lire toutes les instructions AVANT de commencer. Pour toute assistance technique ou obtention de pièces manquantes, appeler le service des relations avec la clientèle au 1-800-241-7219.

Informations importantes concernant la sécurité



- ATTENTION – Avant de conduire, s'assurer que le pare-insectes est solidement assujétié sur le véhicule.
- Ne pas utiliser les stations de lavage de voitures à brosse.
- Ne pas utiliser de solvants.
- Vérifier régulièrement le serrage des composants.

Contenu **NOTE:** Le produit réel peut changer de l'illustration.



Pare-insectes



Butoirs (4)

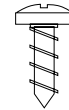

Vis (2)



Rondelle (2)



Écrou Bon (2)

Outils nécessaires



Fournitures pour lavage de voiture

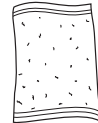

Serviette propre

Préparation pour la peinture/l'installation

- Il est recommandé de procéder à un essai pour s'assurer que le positionnement et l'ajustement sont corrects.
- Vérifier l'ajustement des pièces avant peinture, car nous n'acceptons pas le retour de pièces modifiées ou peintes.
- Laver les glissières de glaces de la portière du véhicule pour éliminer toute poussière et tous débris.
- Sécher les glissières avec une serviette propre.

Étapes d'installation **REMARQUE :** La méthode d'application peut être légèrement différente de celle représentée par les illustrations.

Ouvrir le capot et localiser le loquet du capot, derrière la calandre avant.

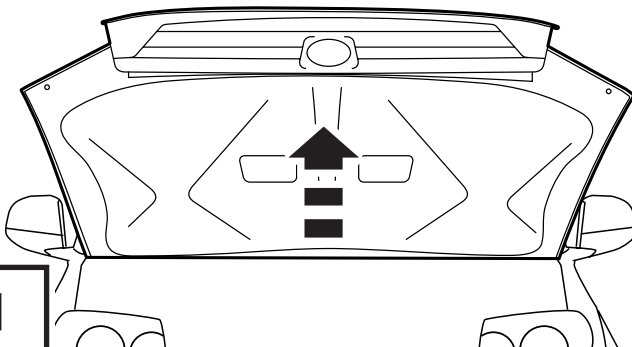

1

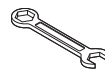

À l'aide d'une clé, retirer (2) vis pour retirer l'ensemble du loquet du capot.

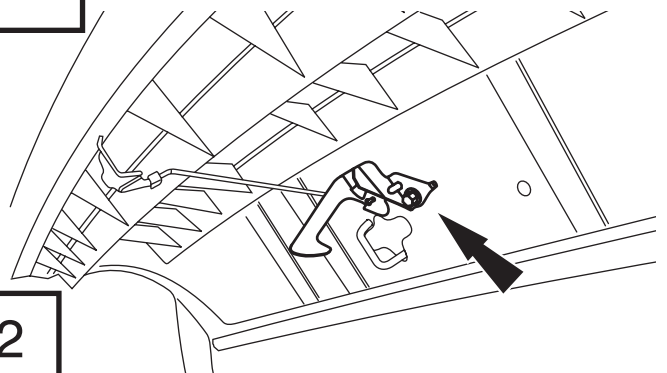

2

Étapes d'installation

REMARQUE : La méthode d'application peut être légèrement différente de celle représentée par les illustrations.



Localiser et retirer les (8) écrous qui retiennent la calandre avant au capot. Mettre la calandre de côté.

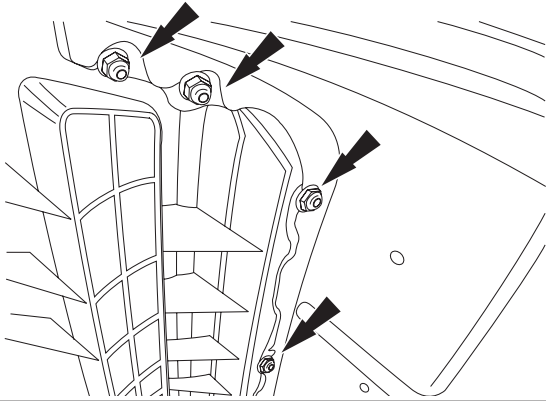

3

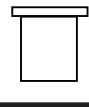

Insérer (2) écrous Well-Nut dans les trous qui se trouvent de chaque côté du dessous du capot.

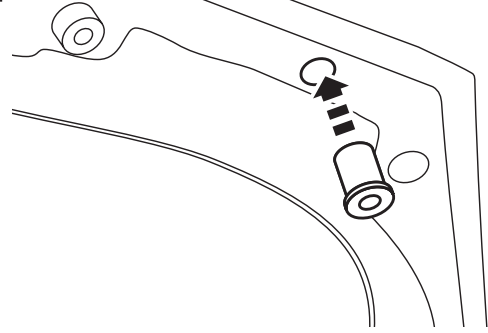

4

Positionner le pare-insectes sur le capot, et aligner les trous du pare-insectes et l'écrou Well-Nut.

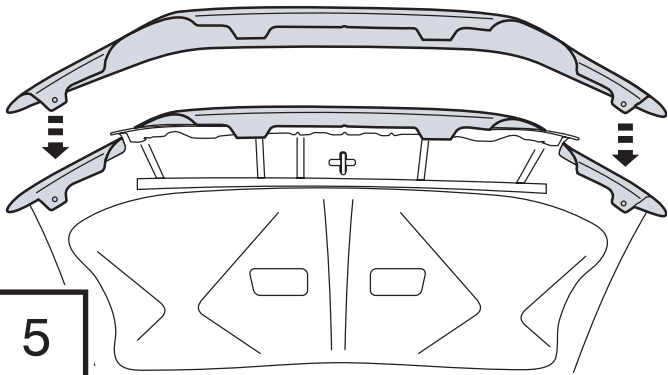

5

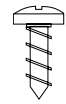

Installer (1) rondelle et (1) vis pour fixer le tout en place. Les resserrer jusqu'à ce qu'elles soient bien en place. Répéter la procédure du côté opposé.

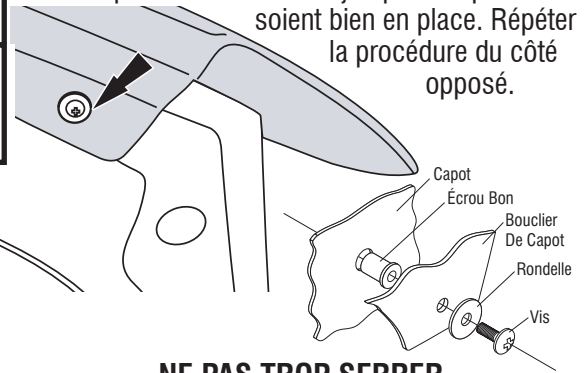
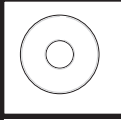

6

NE PAS TROP SERRER



Fixer la calandre avant en place en réinstallant les (8) écrous précédemment retirés. Le rebord du pare-insectes doit se trouver entre le capot et la calandre.

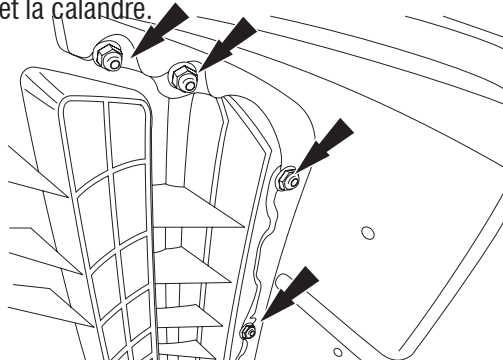

7

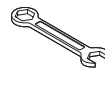

Fixer à nouveau en place le loquet du capot sur le dessous du capot, en réinstallant les (2) vis précédemment retirées.

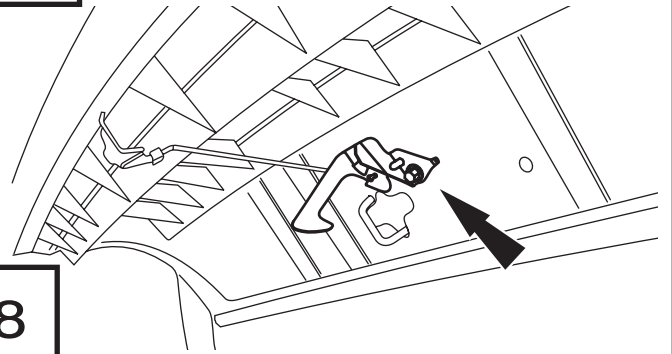

8



Installer les butoirs aux endroits prénettoyés de la surface du capot, là où le pare-insectes pourrait entrer en contact.

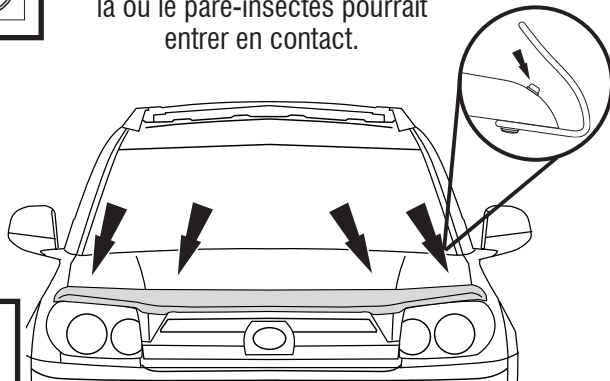

9

Entretien et nettoyage

- Laver exclusivement avec de l'eau savonneuse et sécher avec un chiffon propre.

Félicitations !

Vous avez acheté l'un des nombreux produits de qualité Auto Ventshade™ fabriqués par Lund International, Inc. Nous sommes extrêmement fiers de nos produits et souhaitons que vous tiriez des années de satisfaction de votre investissement. Nous avons pris toutes les mesures nécessaires pour assurer que ce produit est d'une qualité supérieure en ce qui concerne l'ajustement, la durabilité, la finition et la facilité d'installation.



Lund International

800-241-7219 • Visitez notre site lundinternational.com

© 2012 Lund International, Inc. Tous droits réservés.



Auto Ventshade™, le logo Auto Ventshade™ et le logo AVS™ sont des marques déposées de Lund International, Inc.





Bugflector® - Bugflector II® - Carflector®

Para una instalación adecuada y el mejor ajuste posible, lea todas las instrucciones ANTES de comenzar. Si desea recibir asistencia técnica u obtener piezas faltantes, llame al Servicio al cliente al 1-800-241-7219.

Información importante de seguridad



- PRECAUCIÓN - Antes de conducir, asegúrese de que la visera deflectora esté correctamente anclada al vehículo.
- No utilice servicios automáticos de limpieza de vehículos que utilizan cepillos.
- No utilice limpiadores al solvente de ningún tipo.
- Compruebe periódicamente que todos los componentes estén ajustados.

Contenido

NOTA: El producto real puede variar de la ilustración.



Cubierta para capó



Soporte (4)

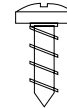

Tornillo
(2)



Arandela
(2)



Tuerca Bien
(2)

Herramientas necesarias



Equipo de limpieza de vehículos



Toalla limpia

Preparación antes de pintar o instalar

- Se recomienda realizar un ajuste de prueba para asegurar el posicionamiento y ajuste correctos.
- Compruebe que las piezas se ajusten correctamente antes de pintarlas, ya que no aceptaremos la devolución de piezas modificadas o pintadas.
- Lave los canales de la ventanilla del vehículo para quitar los desechos y la suciedad.
- Seque los canales de la ventanilla con una toalla limpia.

Pasos de instalación

NOTA: El uso real puede variar levemente de ilustraciones.

Abra el capó y ubique el sistema de cierre del capó que se encuentra detrás de la parrilla delantera.

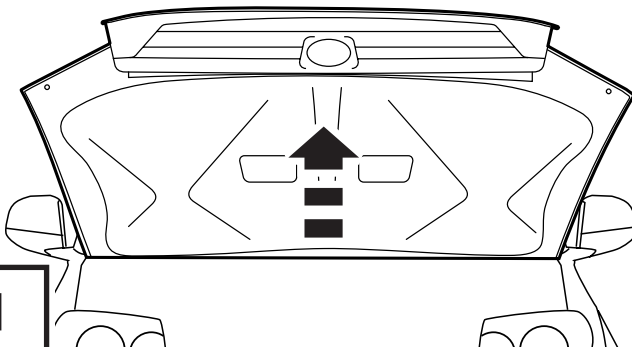

1

Desconecte el sistema de cierre del capó quitando (2) tornillos con una llave.

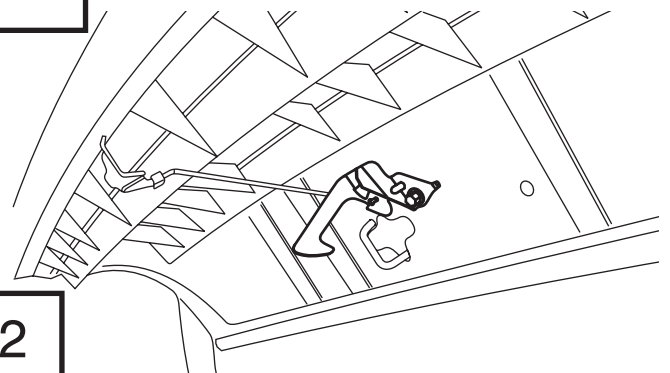
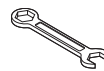

2

Pasos de instalación

NOTA: El uso real puede variar levemente de ilustraciones.



Ubique y quite las (8) tuercas que fijan la parrilla delantera al capó. Aparte la parrilla.

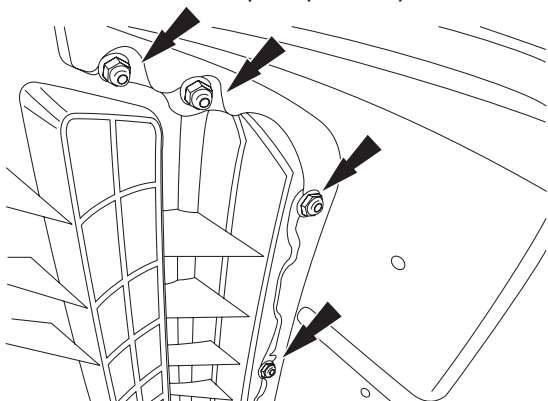

3

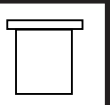

Coloque (2) tuercas remache en cada uno de los lados en la parte inferior del capó.

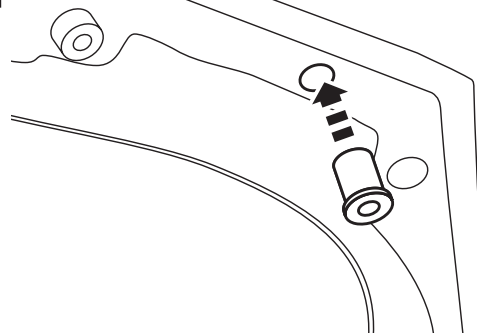

4

Coloque la cubierta para capó en el capó y alinee los orificios de la cubierta para capó con la tuerca remache.

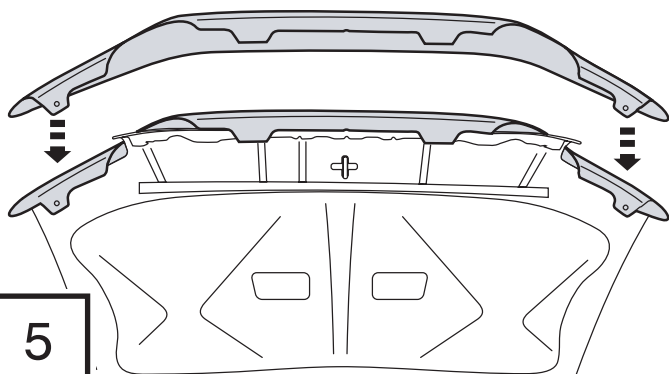

5



Coloque (1) arandela y (1) tornillo para ajustar. Ajuste hasta que quede firme. Repita el procedimiento para el otro lado.

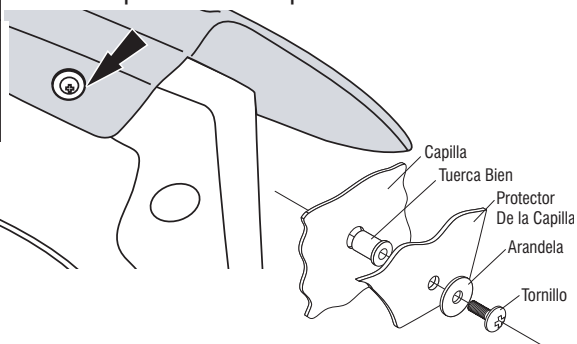

6

NO AJUSTE DEMASIADO



Vuelva a colocar la parrilla delantera colocando las (8) tuercas que había quitado previamente. El reborde de la cubierta para capó debe colocarse entre el capó y la parrilla.

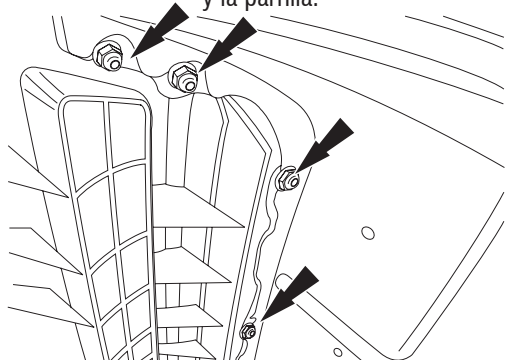

7



Vuelva a colocar el seguro del capó en la parte inferior del capó colocando los (2) tornillos que había quitado previamente.

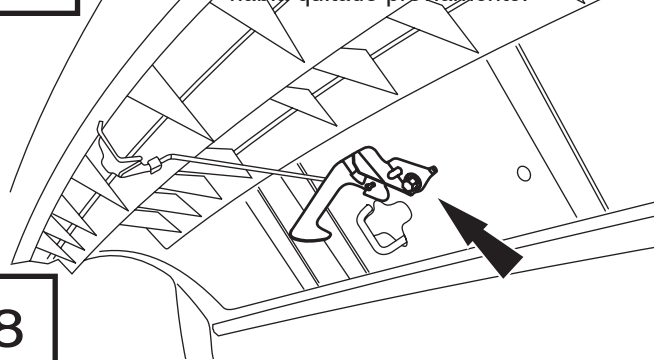

8



Coloque los soportes en las ubicaciones que limpió previamente en la superficie del capó donde la cubierta para capó hará contacto.

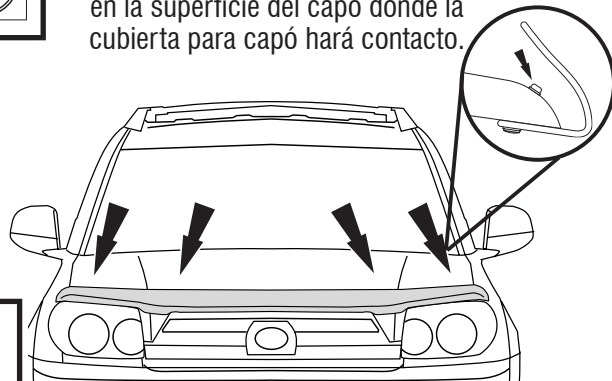

9

Cuidado y limpieza

- Limpie solamente con agua jabonosa tibia y seque con un paño limpio.

Felicidades

Usted ha comprado uno de los tantos artículos de calidad de Auto Ventshade™ ofrecidos por Lund International, Inc. Nuestros productos son nuestro mayor orgullo. Deseamos que disfrute de años de satisfacción con su inversión. Hemos realizado todos los esfuerzos para asegurarnos de que su producto sea de la mejor calidad en cuanto a ajuste, durabilidad, acabado y facilidad de instalación.



Lund International

800-241-7219 • Visite nuestro sitio Web: lundinternational.com

© 2012 Lund International, Inc. Todos los derechos reservados.



Auto Ventshade™, el logo de Auto Ventshade™ y el logo de AVS™ son marcas comerciales de Lund International, Inc.

