

# BACKRACK™

FUNCTION AND STYLE FOR TODAY'S TRUCKS

## INSTALLATION INSTRUCTIONS #INST030:

BACKRACK KIT #30147

Dodge Ram 2009-2016 - 5.5 ft Ram Box Only

### READ THIS NOW!

Your truck should look like the one shown. If you think you are missing any parts, think that this part number is not for your truck or have any installation question, call our customer service department at toll free:

**800-265-8137** or locally **905 849-3633**.

Other ways to reach BACKRACK:

Fax **905-849-4116**

email: [techsupport@backrack.ca](mailto:techsupport@backrack.ca)



The BACKRACK is secured to your truck with a pair of "Stake Pocket Bolts" specifically designed for your make and model of truck. These bolts mount into each of the two front stake pockets. The BACKRACK assembly sits on the bed rails of your truck and is secured to these Stake Pocket Bolts. If your truck has a BEDLINER we suggest you remove it to install the Stake Pocket Bolts

#### PARTS LIST FOR KIT #30147

PART	DESCRIPTION	QTY
RMB547D	Rail Mount Bracket Driver	1
RMB547P	Rail Mount Bracket Passenger	1
<b>HARDWARE BAG547</b>		
INST030	Installation Instructions	1
FYZ008	1/2"-20 Nylon Hex Lock Nut	2
FYZ009	1/2"-13 Hex Nut	2
FYZ010	1/2" Lock Washer	6
FYZ011	1/2" Flat Washer	10
FYZ014	1/2"-20 x 3.25" Carrige Bolt Grade 8	2
FYZ033	1/2"-13 Hex Bolt Grade 5	6
FYZ035	Threaded Square Plate	4

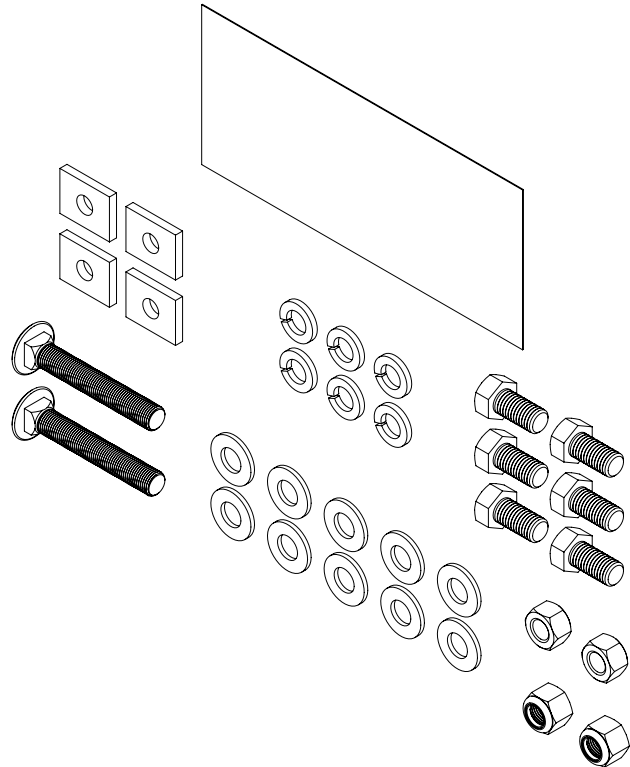

**FOR MORE INFORMATION SCAN HERE!**



# BACKRACK™

FUNCTION AND STYLE FOR TODAY'S TRUCKS

1

Install two (per side) T-nuts per side into C channel on truck bed

**OPTIONAL DRILL:**

On the rail mount bracket, there is an additional hole to allow for an additional bolt, this will require drilling the bed of the truck.

Align the rail mount bracket into position (see step 3 for approx position) Mark hole position with felt tipped pen. Drill center of marked position with a 9/16" drill.

**\*\*USE EXTREME CAUTION WHEN DRILLING\*\***

Improper drilling can cause damage to your truck bed and/or cab.

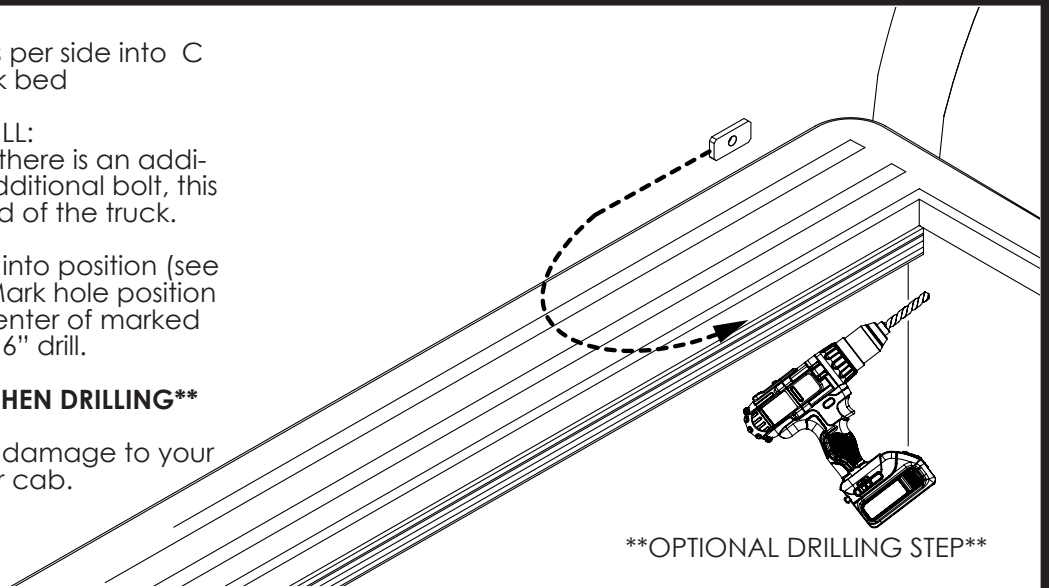

2

Fasten Backrack to the Rail mount bracket. Finger tighten at this stage.

**\*\*IMPORTANT\*\***

Install the carriage bolt as shown in the diagram with the round head closest to the cab. Failure to do so could result in damage to the cab or rear window.

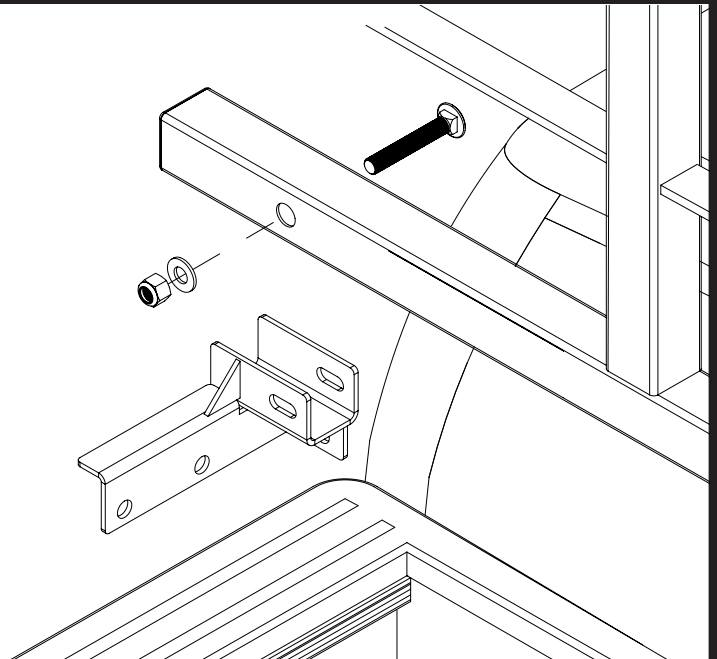

3

Fasten Backrack Assembly to the C channel on truck bed, align the T nuts and install bolt, lock washer and washer. Center the Backrack assembly on the truck and final torque all bolts starting with the nuts on the inside of the truck bed, then the rail mount bracket and finally the main BACKRACK carriage bolt

