



Installation Instructions
HighRock 4x4™ Off-Road Bumper - Front
HighRock 4x4™ Tubular Grill Guard (sold separately)

Vehicle Application:
 Jeep® JK & JL Wrangler & Unlimited and JT
 Gladiator 2007- current
 Part Number 42933/44933
 Grill Guard Part Number 42915/44915

Installation Tips

Before you begin installing your new HighRock 4x4™ Off-Road Bumper, please read all the instructions thoroughly.

WARNING Do not rely in any way on the components of this product to protect against injury or death in the event of an accident. Never operate the vehicle in excess of manufacturer's specifications.

Read and follow, precisely, all installation instructions provided when installing this product. Failure to do so may result in a poor fit and could place occupants of the vehicle in a potentially dangerous situation.

WEAR SEAT BELTS AT ALL TIMES

CAUTION Safety glasses should be worn at all times when installing this product.



Tools				
Safety Glasses	18mm - 3/8" Wrench	Socket Wrench	7 - 10- 13mm 15 - 16 - 18mm 3/8" - 1/2" Sockets	17mm - 18mm Deep-Well Sockets
Utility Knife	T20 Torx Driver	3/16" - 6mm Allen Wrenches	Long Flat-Blade Screwdriver	
Wire Stripper- Crimper	Pry Bar	Pliers	Phillips Screwdriver	

Installation Time



4 hours

Skill Level

① ② ③ ④

4 - Difficult

Support

We're here to help! Go to:
<https://www.bestop.com>
 and click on **Need Help?**



<https://www.bestop.com/video-library>



Installation Instructions
HighRock 4x4™ Off-Road Bumper - Front
HighRock 4x4™ Tubular Grill Guard (sold separately)

Vehicle Application:
 Jeep® JK & JL Wrangler & Unlimited and JT
 Gladiator 2007- current
 Part Number 42933/44933
 Grill Guard Part Number 42915/44915

Parts List - Required parts for installation

Sections 3 to 8 **Bumper, Light Housings; Light Rings, Hardware** **Pages 6 to 10 of Guide**

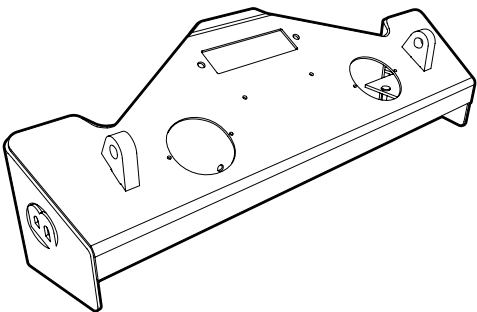

Front Bumper
 42933 - Part #479.18 (gloss finish)
 44933 - Part #498.15 (matte finish)
 Qty. 1

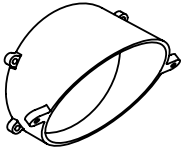

Fog Light Housing
 Part #479.20
 Qty. 2

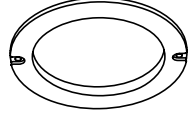

Fog Light Mounting Ring
 Part #479.21
 Qty. 2

Parts Bundle
Part #485.73



M10 Nylon Lock Nut
 Part #422.76
 Qty. 8



M10 Flat Washer
 Part #422.77
 Qty. 8



#10-24 Nylon Lock Nut
 Part #486.50
 Qty. 4

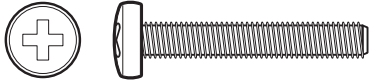

#10-24 x 1" Pan Head Screw
 Part #486.51
 Qty. 4

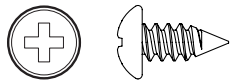

#12 x 1/2" Pan Head Screw
 Part #486.49
 Qty. 8

Sections 3 to 8 **Fog Light Brackets, Hardware** **Pages 6 to 10 of Guide**

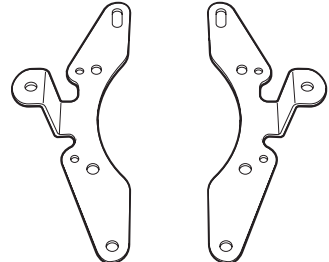

Fog Light Brackets
 Part #581.09 - Left
 Part #581.08 - Right
 Qty. 2 of each

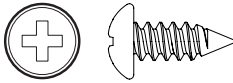

#10 x 5/8" Screw
 Part #728670
 Qty. 8

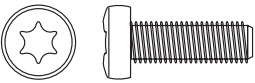

M4 x 15mm
 Torx Screw
 Part #494.03
 Qty. 8



M4 Nylon Lock Nut
 Part #523.17
 Qty. 8



M4 Flat Washer
 Part #539.67
 Qty. 8

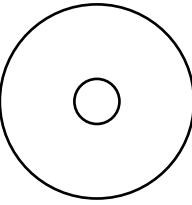

Fender Washer
 Part #586.58
 Qty. 12

Parts Bundle
Part #581.10



Installation Instructions
HighRock 4x4™ Off-Road Bumper - Front
HighRock 4x4™ Tubular Grill Guard (sold separately)

Vehicle Application:
Jeep® JK & JL Wrangler & Unlimited and JT
Gladiator 2007- current
Part Number 42933/44933
Grill Guard Part Number 42915/44915

Parts List - Required parts for installation

All Sections

Optional Tubular Grill Guard

Pages 4 of Guide

HighRock 4x4™ Tubular Grill Guard
Sold Separately

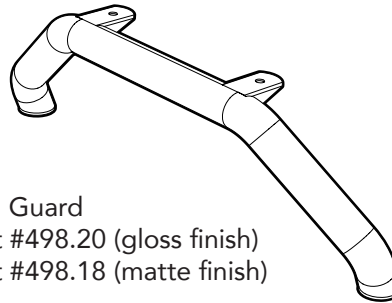

Tubular Grill Guard
42915 - Part #498.20 (gloss finish)
44915 - Part #498.18 (matte finish)
Qty. 1

Parts Bundle
Part #498.36

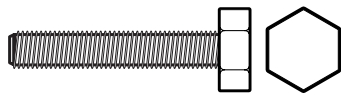

Hex Head Bolt
Part #414.26
Qty. 4

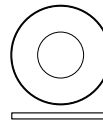

Flat Washer
Part #414.27
Qty. 4

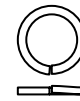

Split Lock Washer
Part #414.28
Qty. 4

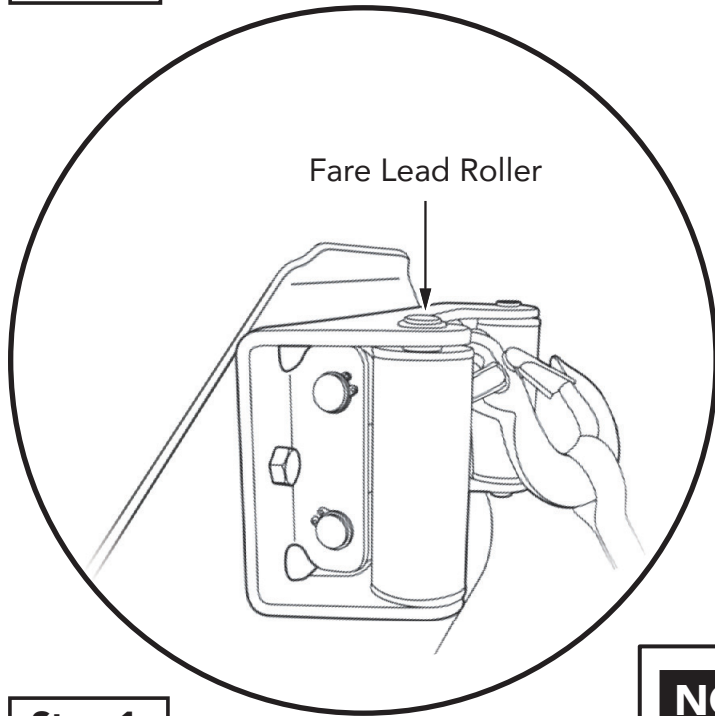
Step 1**Step 1**

If you have a fare lead roller, use the mounting hardware provided with the roller to install it on the bumper.

NOTE

If you intend to install a fare lead roller and/or a winch on your bumper, you will need to install them on the bumper before you install the bumper on the vehicle.

If you decide at a later date to install a fare lead roller or winch on your vehicle, it will be easiest to remove the bumper from the vehicle before installing.

If you wish to install a winch without a fare lead roller, skip step 1 on this page.

If you do not wish to install a fare lead roller or winch at this time, skip steps 1 and 2 on this page.

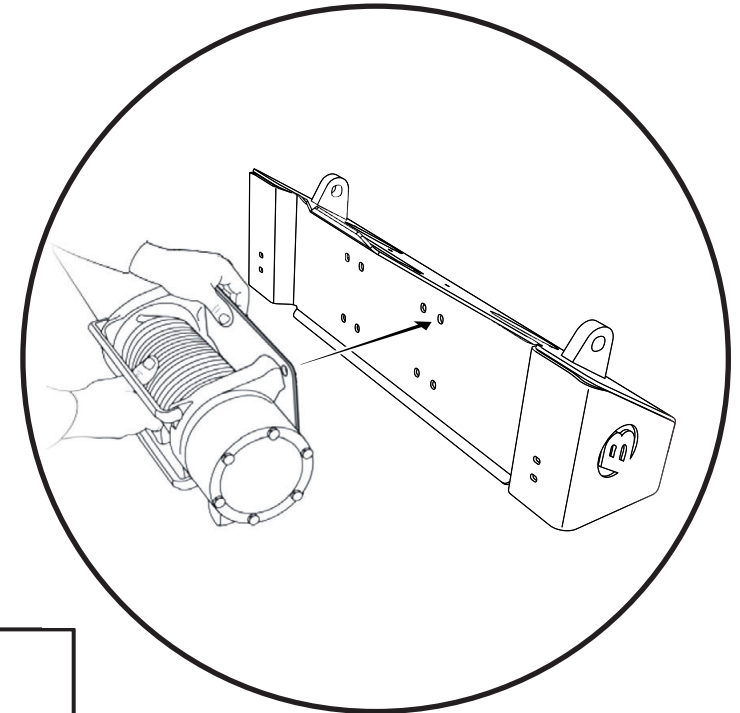
Step 2**Step 2**

Place the Front Bumper Part #479.18 (gloss finish) - OR - Part #498.15 (matte finish) on a flat surface.

Place the winch assembly on the bumper and align the mounting holes.

Use the hardware provided with the winch to secure it to the Bumper.

Step 1

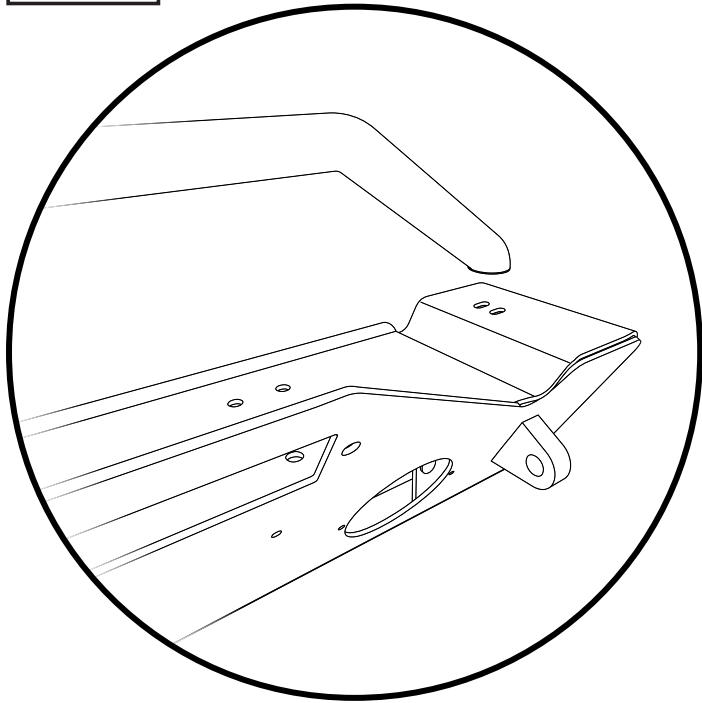

Hardware

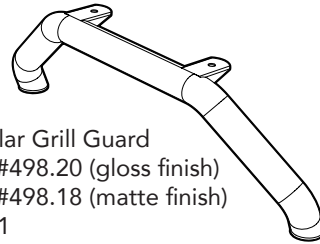

Tubular Grill Guard
Part #498.20 (gloss finish)
Part #498.18 (matte finish)
Qty. 1

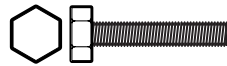

Hex Head Bolt
Part #414.26
Qty. 4



Flat Washer
Part #414.27
Qty. 4



Split Lock Washer
Part #414.28
Qty. 4

Tools

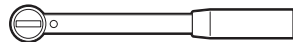

Socket wrench
and 13mm
socket

Step 2

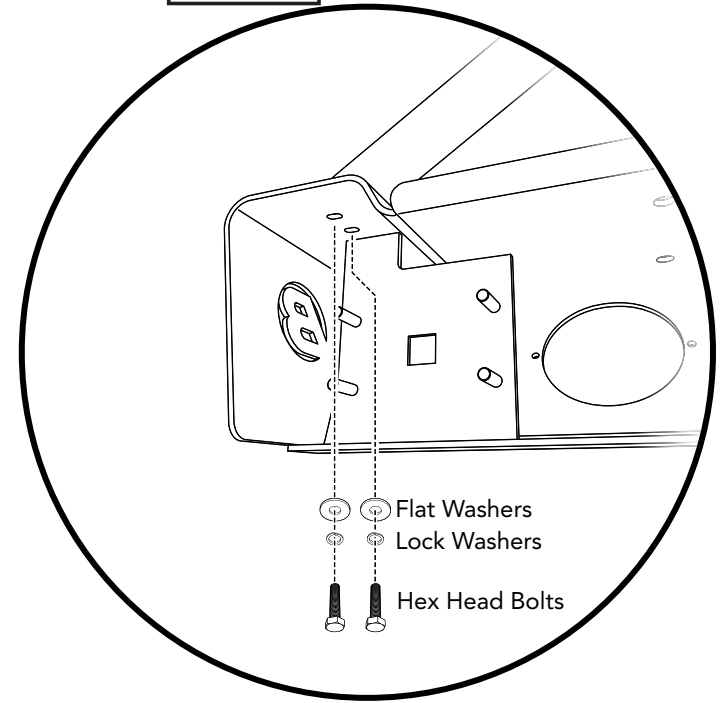

Flat Washers
Lock Washers
Hex Head Bolts

Step 2

From the underside of the Bumper, use four (4) Hex Head Bolts #414.26, four (4) Flat Washers #414.27, and four (4) Split Lock Washers #414.28 to secure the Grill Guard to the Bumper.

Instructions for Vehicles with OEM Plastic Bumper: Pages 6 to 9

Step 1

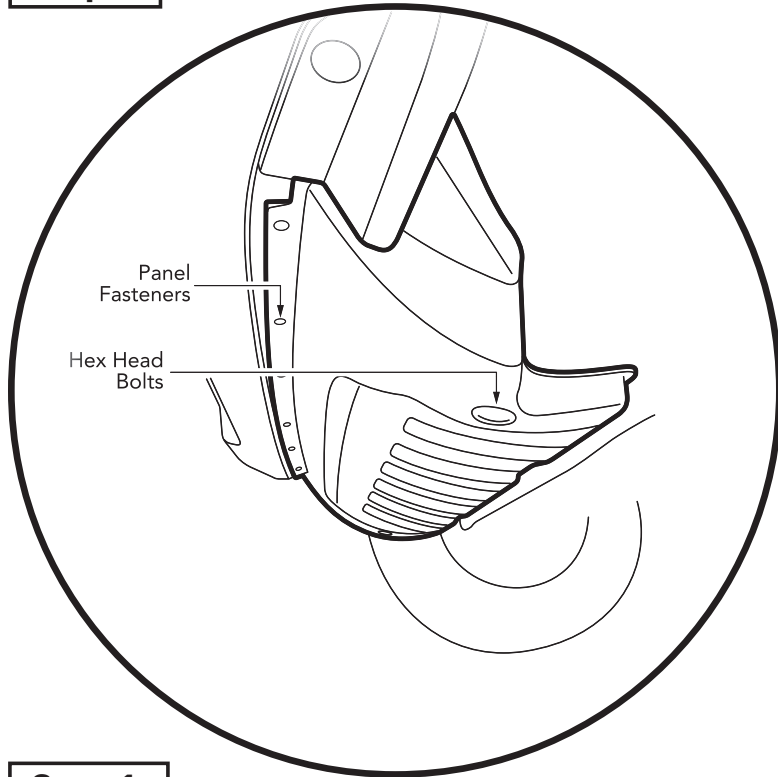

Tools



Socket Wrench



18mm & 7mm Sockets

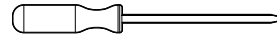

Flat Blade Screwdriver

Step 2

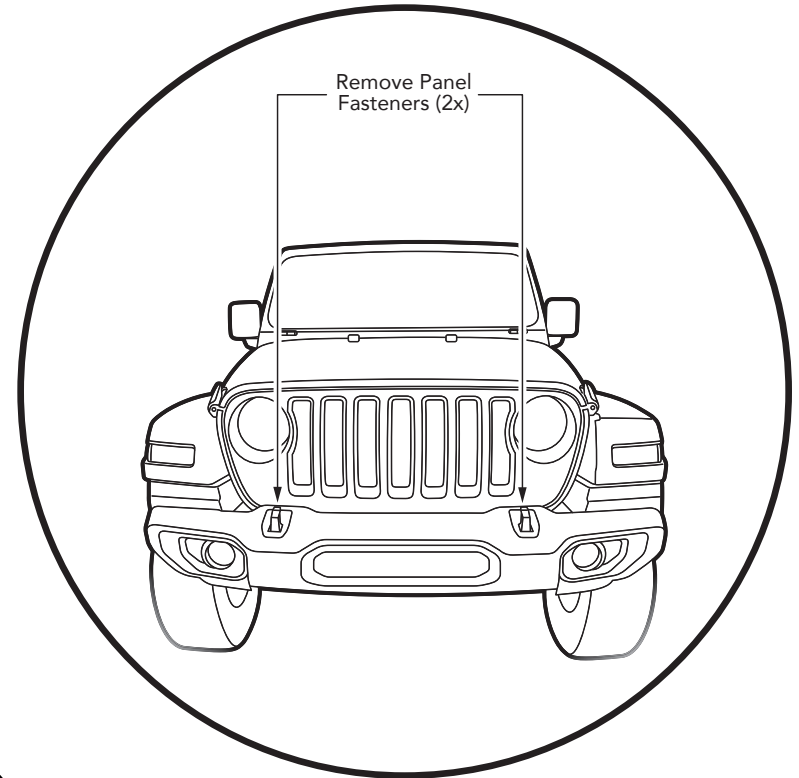

Step 1

Remove 8 Panel Fasteners and 2 Hex-Head Bolts from the underside of the factory Skid Plate, and remove the Skid Plate from the Jeep.

Detail

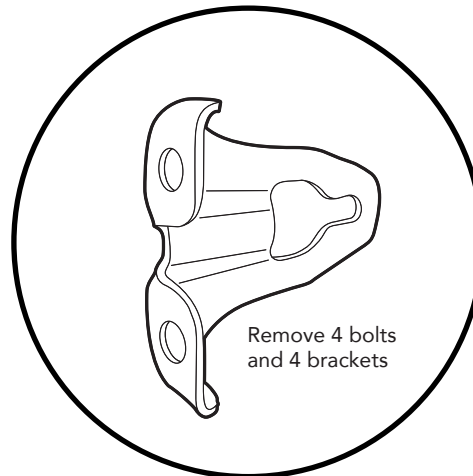

Step 2

NOTE: Unplug the Fog Light connector, located behind the bumper on the passenger side, before removing the factory bumper.

Remove eight (8) 18mm nuts attached to the studs on the inside of the bumper. These nuts attach the bumper to the Jeep frame.

Remove four (4) 16mm hex head bolts and the four (4) attached brackets. See Detail of bracket.

Instructions for Vehicles with OEM Plastic Bumper: Pages 6 to 9

Step 1

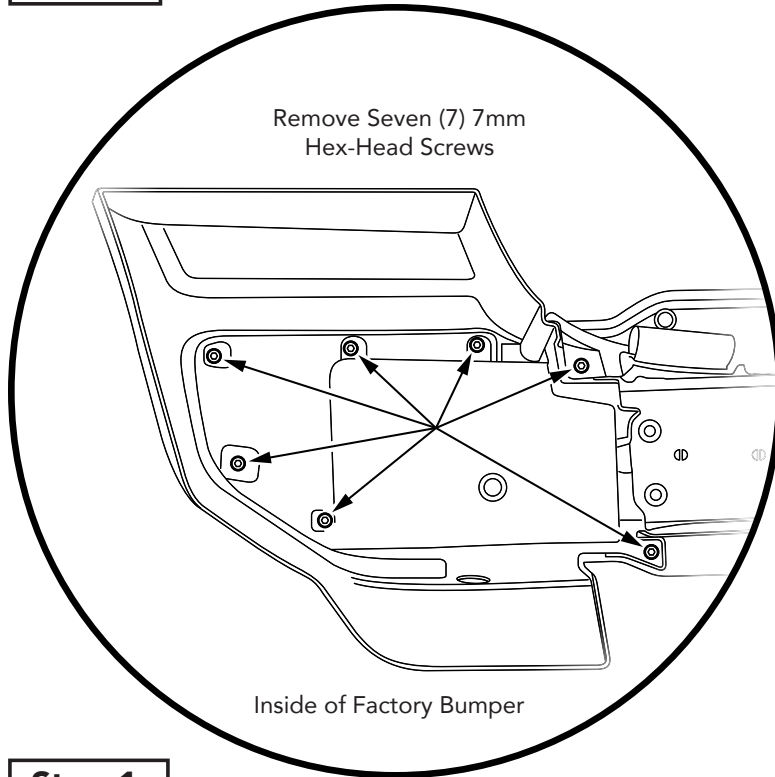

Tools

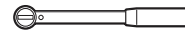

Socket Wrench



7mm Socket

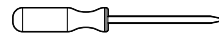

Flat Blade Screwdriver



T20 Torx Driver

Step 2

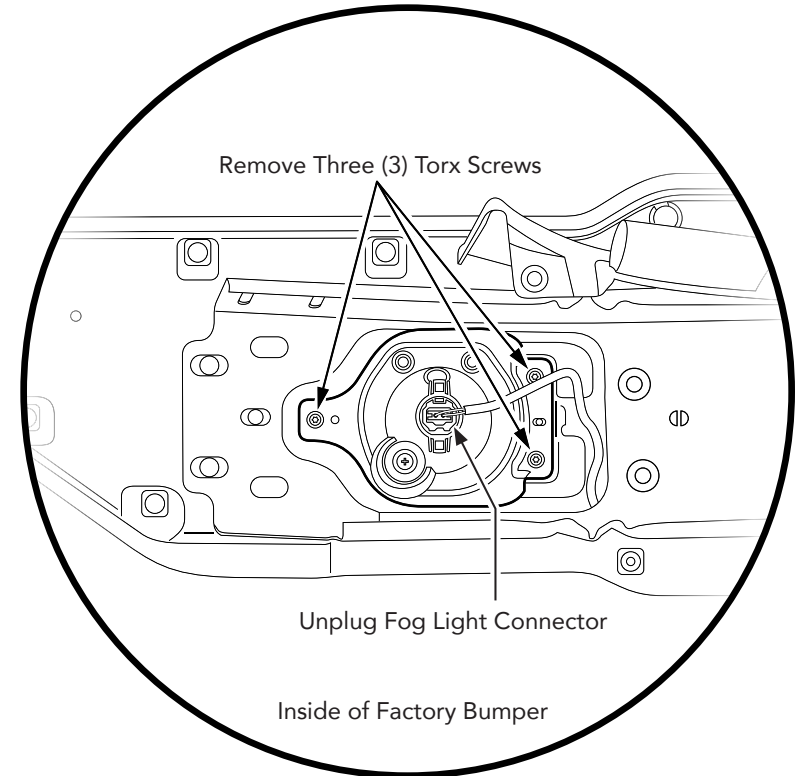

Step 1

Remove One (1) Panel Fastener and seven (7) Hex-Head Screws from the back side of the factory Bumper, and remove the Fog Light Rear Cover Panel.

Repeat for both Fog Lights.

Step 2

Remove three (3) T20 Torx Screws from the fog light bracket.

Unplug the Fog Light Connector.

Remove the Fog Light from the factory bumper.

Repeat for both Fog Lights.

Step 1

Instructions for Vehicles with OEM Plastic Bumper: Pages 6 to 9

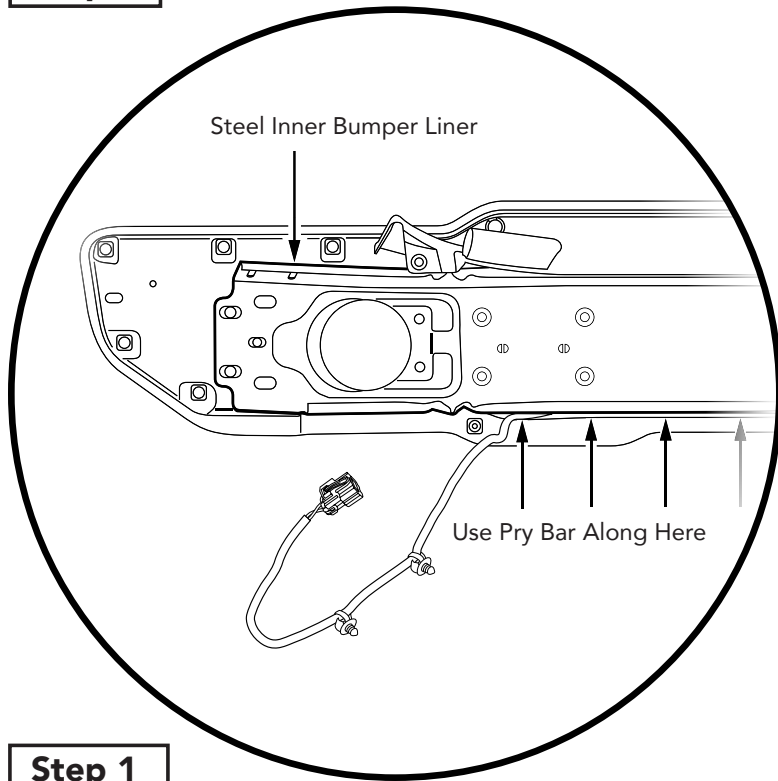

Hardware

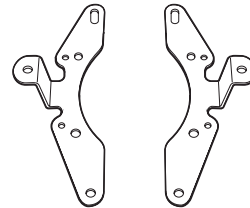

Fog Light Brackets
Part #581.09 - Left
Part #581.08 - Right
Qty. 2 of each

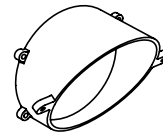

Fog Light Housing
Part #479.20
Qty. 2

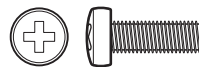

#10 x 5/8" Screw
Part #728670
Qty. 8

Tools

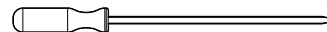

Long Flat-Blade Screwdriver



Pry Bar

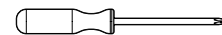

Phillips Screwdriver

Step 2

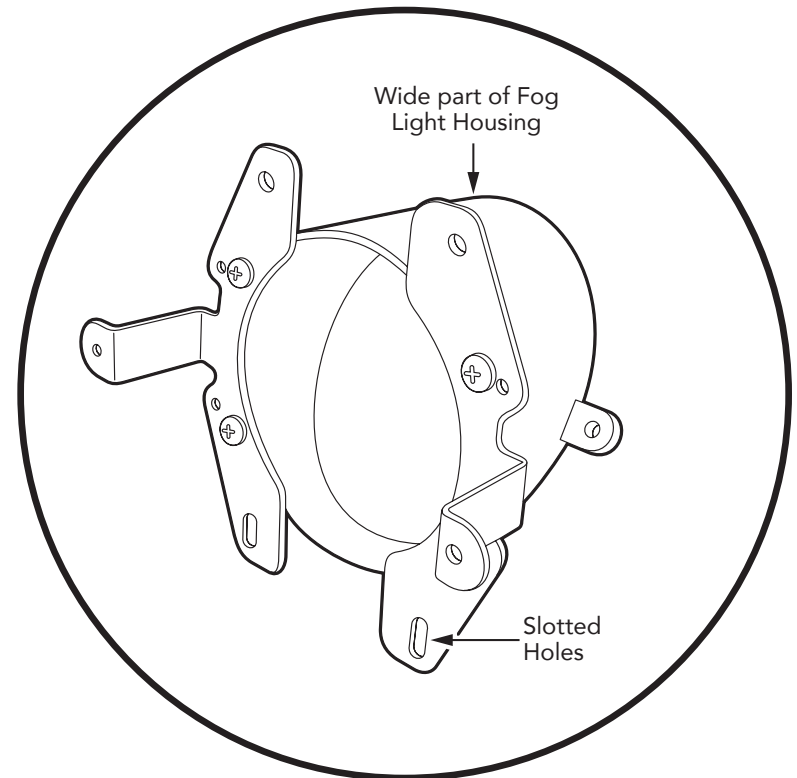

Step 2

Attach the Fog Light Brackets #581.08 and #581.09 to the Fog Light Housings #479.20.

Orient the Fog Light Housing with the wide part of the housing up, and attach the brackets as shown, with the slotted holes in the brackets on the bottom.

Attach the Brackets to the Housings using four (4) #10x5/8" #728670 Phillips Screws for each assembly.

Step 1

WARNING

This step is difficult. May take two people to accomplish and may damage the OEM bumper and wire harness.

From the back side of the factory bumper, use a pry bar to open a gap between the steel inner bumper liner and the plastic outer bumper fascia.

Use a long flat-blade screwdriver to pop out the seven (7) cable harness guides located between the bumper fascia and the liner, and remove the cable harness.

OR - you may order the factory OEM fog light wire harness from MOPAR. Part #6833 6461 AC

Instructions for Vehicles with OEM Plastic Bumper: Pages 6 to 9

Step 1

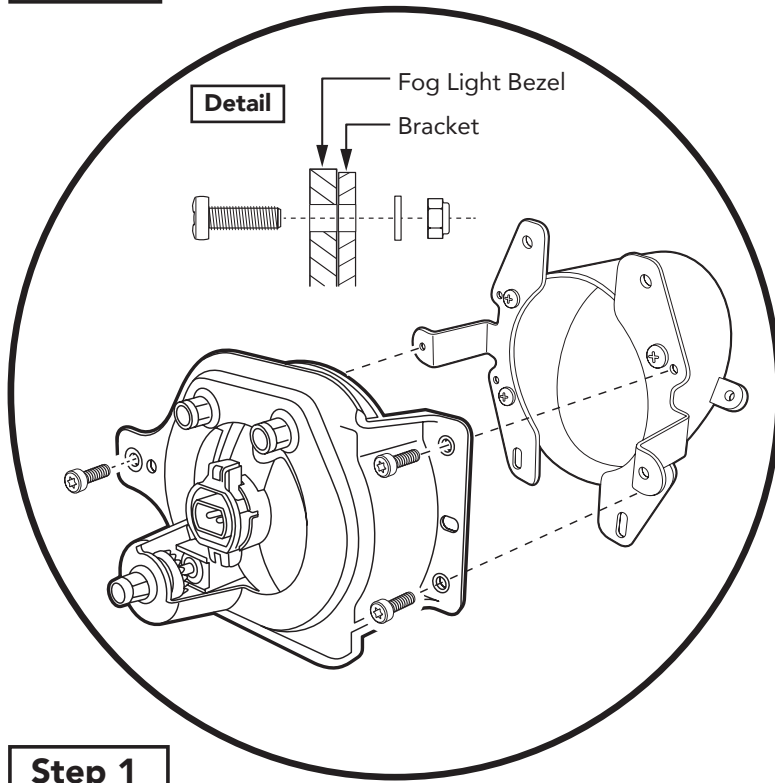

Hardware



M4 x 15mm
Torx Screw
Part #494.03
Qty. 6



M4 Nylon Lock Nut
Part #523.17
Qty. 6



M4 Flat Washer
Part #539.67
Qty. 6



#10-24 x 1"
Pan Head Screw
Part #486.51
Qty. 4



#10-24 Nylon Lock Nut
Part #486.50
Qty. 4

Tools



Socket
Wrench



7mm
Socket



T20 Torx
Driver

Step 1

Attach the Fog Lights to the Bracket-Housing Assemblies.

Use 3 three (3) M4x15mm Torx Screws #494.03, three (3) M4 Flat Washers #539.67, and three (3) M4 Nylon Lock Nuts #523.17 per assembly. See Detail.

NOTE: Fog Lights are marked with LH (driver side) and RH (passenger side). Lights are also marked with "Up". Wide part of Fog Light Housing is always at the top of the assembly.

Tabs on Light bezels go to the outside.

Step 1

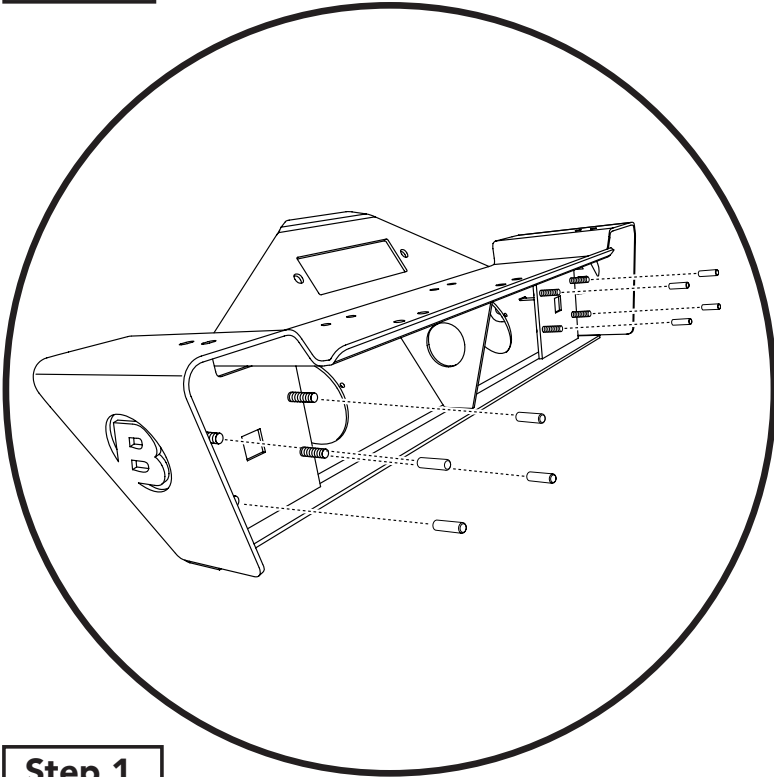

Step 1

Remove thread protector caps from eight (8) studs on back side of new Bumper.

Hardware

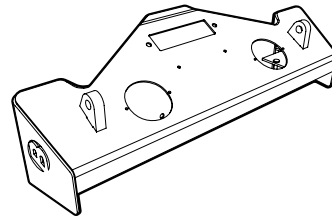

Front Bumper
42933 - Part #479.18 (gloss)
44933 - Part #498.15 (matte)
Qty. 1

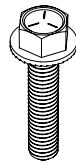

16mm Hex Head Bolts
Removed earlier
Qty. 4



18mm Nuts
Removed earlier
Qty. 8

Detail

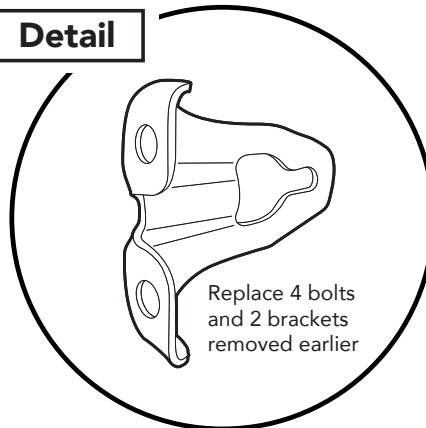

Replace 4 bolts
and 2 brackets
removed earlier

Step 2

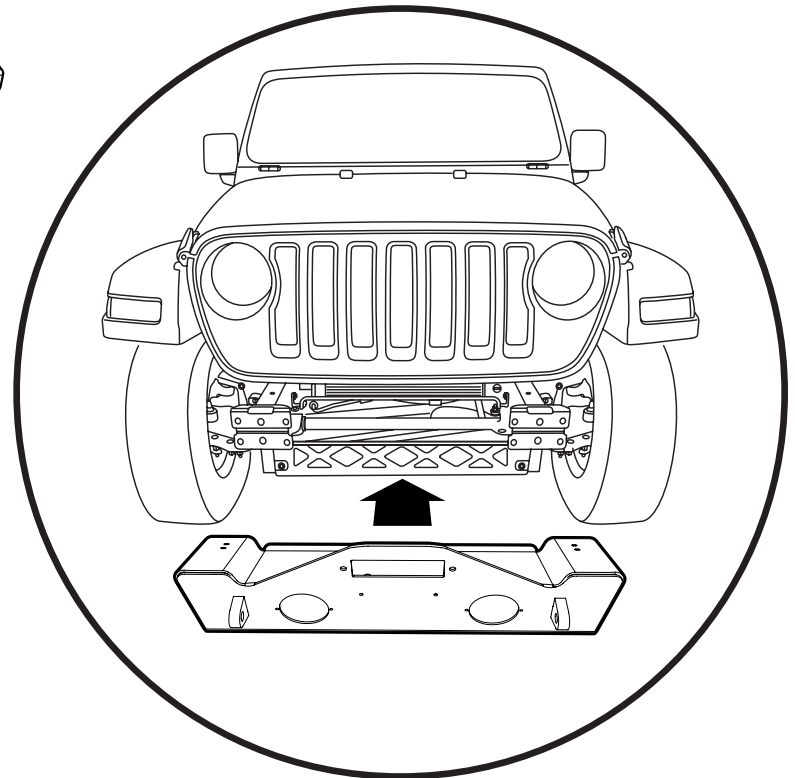

Step 2

NOTE: Use two people for this step.

Slide the Bumper #479.18 (gloss) -OR- #498.15 (matte) studs onto the vehicle mounting flanges.

Re-attach the four brackets you removed earlier (see Detail) using the four (4) 16mm hex head bolts also removed earlier.

Secure the Bumper using the eight (8) 18mm nuts you removed in an earlier step.

Step 1

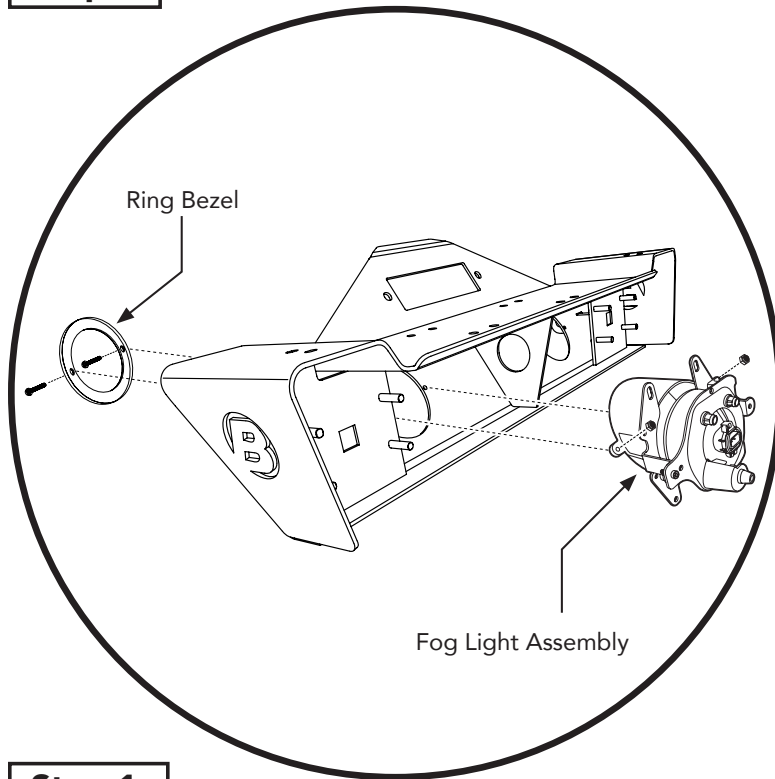

Hardware

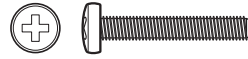

#10-24 x 1"
Pan Head Screw
Part #486.51
Qty. 4



#10-24 Nylon Lock Nut
Part #486.50
Qty. 4

Tools

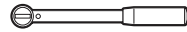

Socket
Wrench



7mm
Socket



Phillips Screwdriver

Step 1

Attach the Fog Light assemblies and outer Ring Bezels #479.21 to the Bumper, using two (2) #10-24 x 1" Pan Head Screws #486.51 and two (2) #10-24 Nylon Lock Nuts #486.50 per light assembly.

If tightening the Light Assemblies and Ring Bezels to the Bumper is difficult, you may need to loosen the screws holding the Fog Lights to the Fog Light Housings #479.20.

Re-tighten these screws after installing the Fog Light assemblies and Ring Bezels.

Step 2

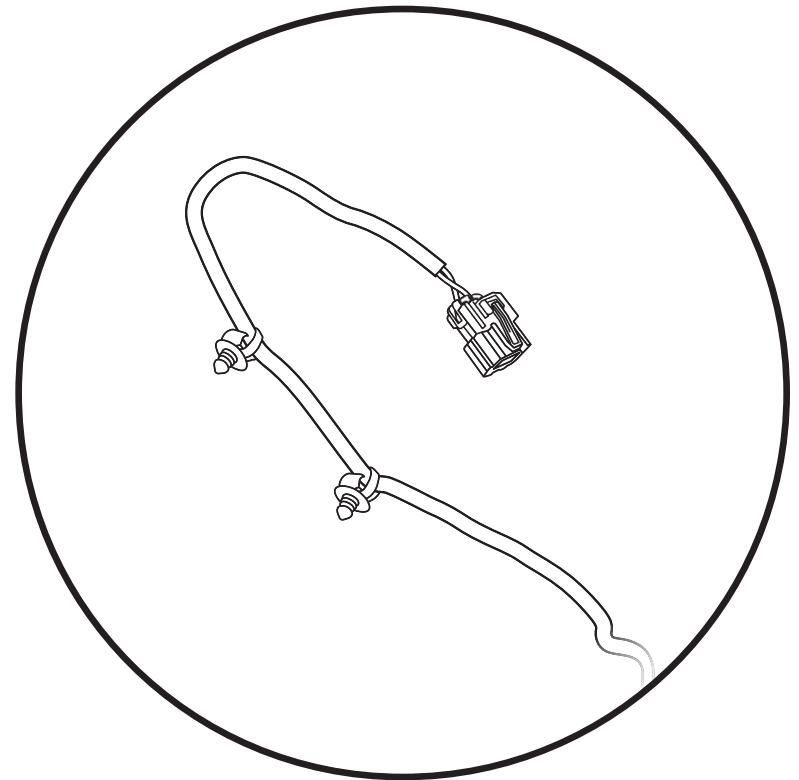

Step 2

Replug the Fog Light wiring harness connectors behind the Bumper.

NOTE: Remember to move your front license plate from the old bumper to the new one (if you have a front plate).



Warranty Information
HighRock 4x4™ Off-Road Bumper - Front
HighRock 4x4™ Tubular Grill Guard (sold separately)

Vehicle Application:
Jeep® JK & JL Wrangler & Unlimited and JT
Gladiator 2007- current
Part Number 42933/44933
Grill Guard Part Number 42915/44915

WHAT BESTOP WARRANTS

Subject to the terms and conditions of sale, including any terms and conditions set forth by Bestop, Inc. ("Bestop" or "us" or "we") in our then-current terms of sale on our website (collectively, the "Terms"), Bestop represents and warrants that: the covered products listed in the "Covered Products and Warranty Periods" section (a "Product") will substantially be free from defects in materials and workmanship for the specified warranty periods set forth in that section.

THE WARRANTY IS LIMITED AND CONDITIONAL

This warranty applies to the original purchaser of the Product only. The warranty is valid only as long as the original retail purchaser owns the vehicle upon which the Product is installed. The warranty expires should the Product be removed from the original vehicle or if the original vehicle is transferred to another owner. This warranty is not transferable or assignable. The warranty does not apply to Product bought from auction-style or price-bid websites.

THE LIMITED WARRANTY AND STATED REMEDIES ARE SOLE AND EXCLUSIVE AND IN LIEU OF ALL OTHER WARRANTIES AND REMEDIES, AND COMPANY EXPRESS DISCLAIMS ALL IMPLIED OR STATUTORY OR OTHER WARRANTIES, INCLUDING WITHOUT LIMITATIONS WARRANTIES OF MERCHANTABILITY, NON-INFRINGEMENT OR FITNESS FOR A PARTICULAR PURPOSE. IN NO EVENT WILL COMPANY BE LIABLE FOR ANY SPECIAL, INCIDENTAL, CONSEQUENTIAL, PUNITIVE, INDIRECT OR EXEMPLARY DAMAGES OF ANY KIND, INCLUDING LOST PROFITS OR REVENUE, HOWEVER CAUSED, WHETHER FOR BREACH OR REPUDIATION OF CONTRACT, TORT, BREACH OF WARRANTY, NEGLIGENCE, OR OTHERWISE, WHETHER OR NOT COMPANY WAS ADVISED OF THE POSSIBILITY OF SUCH LOSS OR DAMAGES. *Some states do not allow exclusion or limitation, so this may not apply to you. This warranty gives you specific legal rights, and you may have other rights which vary from state to state.*

EXCLUSIONS TO THE WARRANTY

The Limited Warranty excludes, and Bestop is not liable in any way for any warranty claims, damages, or defects related to:

- Misuse, abuse, accidents, vandalism, negligence, fire, or improper installation or modification, or improper or inadequate maintenance;
- Failure to comply with any Product documentation, Bestop instructions, or applicable law or regulations; use in extreme conditions
- Force Majeure including but not limited to, earthquake, hurricane, tornado, flooding, or other disasters natural or man-made, civil unrest, strikes, declared or undeclared war, or lack of performance by, or discontinued product of, supply chain partners whose products, software, operations or management is beyond the control of Bestop;
- Damage resulting in breakage (including without limitation, spontaneous breakage, accidental breakage or breakage by any other means) of a Product or any component part;
- Damage to vinyl windows due to misuse, or cracking due to varying weather conditions.

YOUR SOLE REMEDY

During the applicable warranty period, Bestop shall, at its option, either repair or replace any Product that it confirms, in its discretion, is non-compliant with the warranties herein. Bestop will not pay for labor charges associated with installation or removal of the Product. Should a specific Product be discontinued, Bestop may, at its option, replace the discontinued Product with a current product or like product. If Bestop opts to repair or replace your Product as set forth herein, Bestop shall use reasonable efforts to match any patch or replacement to the color and texture of your existing Product. There is no guarantee however, that Bestop will be able to match the color or texture. If Bestop is not able to match the color or texture, it may provide you with a black or neutral colored patch replacement in its discretion.

Please retain your proof of purchase. Original proof of purchase for the Product must accompany any warranty claim. If you have a warranty claim, first you must email Bestop Customer Service at csbestop@bestop.com for instructions. All claims must be emailed to csbestop@bestop.com within 30 days of discovery of a defective Product, but in no event later than thirty days after the end of the applicable Warranty Period (the "Warranty Notice Period"). Warranty claims made after the Warranty Notice Period are null and void and Bestop shall have no responsibility with respect to such claims.

THIS SECTION SETS FORTH BESTOP'S SOLE OBLIGATION & YOUR SOLE REMEDY WITH RESPECT TO ANY DEFECTS OR OTHER PRODUCT ISSUE. ANY PRODUCTS REPLACED UNDER TERMS OF THIS WARRANTY WILL BE COVERED UNDER TERMS & BALANCE OF THE DURATION OF THE ORIGINAL LIMITED WARRANTY FOR SUCH PRODUCT.



Warranty Information
HighRock 4x4™ Off-Road Bumper - Front
HighRock 4x4™ Tubular Grill Guard (sold separately)

Vehicle Application:
Jeep® JK & JL Wrangler & Unlimited and JT
Gladiator 2007- current
 Part Number 42933/44933
 Grill Guard Part Number 42915/44915

COVERED PRODUCTS AND WARRANTY PERIODS: The warranty time periods are as follows for Products manufactured by Bestop:

BESTOP® LIMITED LIFETIME WARRANTY

Trektop® Pro Twill Fabric Top	Sunrider® for Hardtop Twill Fabric Top
Trektop® NX Glide Twill Fabric Top	Replace-a-Top™ Twill Fabric Top
Trektop® NX Twill Fabric Top	Supertop® NX Twill Fabric Top
EZFold™ Soft Tonneaus	Floor & Cargo Liners
ZipRail™ Soft Tonneaus	Pet Barriers
EZRoll™ Soft Tonneaus	

BESTOP® 5-YEAR LIMITED WARRANTY

Trektop® NX Glide™ Top (non-Twill)	Sunrider® for Hardtop (non-Twill)	Replace-a-Top™ Top (non-Twill)	Trektop® NX Top (non-Twill)
Sailcloth Replace-a-Top™	Supertop® NX Top (non-Twill)	Supertop® Classic Soft Top	Supertop® for Truck
Tigertop™ and Halftop™	Sunrider® Complete Soft Top	EZ Fold Hard Tonneau	

BESTOP® 3-YEAR/100K MILES LIMITED WARRANTY

Powerboard® & Powerboard® NX
 Trekstep®, Side Mount
 Trekstep®, Rear Mount

BESTOP® 3-YEAR LIMITED WARRANTY

Pavement Ends Sprint Top

BESTOP® 2-YEAR LIMITED WARRANTY

Trektop® Classic Soft Top
 RoughRider™ Soft Storage

BESTOP® 1-YEAR LIMITED WARRANTY

All other Bestop® & Pavement Ends™ products not specified above.

For further information or request for warranty work, please contact:

Bestop Inc. Customer Service
Toll-Free: (800)845-3567
Main: (303)465-1755
E-mail: csbestop@Bestop.com
Website: www.Bestop.com