



# Installation Instructions Front Bumper Approach Roller

Vehicle Application:  
Jeep® Wrangler 2-Door & Unlimited 2007-2017  
Part Number 44947

## Installation Tips

Before you begin installing your new Front Bumper Approach Roller, please read all the instructions thoroughly.

**WARNING** Do not rely in any way on the components of this product to protect against injury or death in the event of an accident. Never operate the vehicle in excess of manufacturer’s specifications.

Read and follow, precisely, all installation instructions provided when installing this product. Failure to do so may result in a poor fit and could place occupants of the vehicle in a potentially dangerous situation.



## WEAR SEAT BELTS AT ALL TIMES

**CAUTION** Safety glasses should be worn at all times when installing this product.

Tools			Installation Time	Support
 Safety Glasses	 13mm - 16mm 18mm Wrenches	 Socket Wrench	 1-1/2 hours	We're here to help! Go to <a href="http://www.Bestop.com">www.Bestop.com</a> and click on "Contact Us"
		 13mm - 16mm 18mm Sockets	<b>Skill Level</b>  <b>3 - Moderately Difficult</b>	



# Installation Instructions





## Front Bumper Approach Roller

Vehicle Application:  
Jeep® Wrangler 2-Door & Unlimited 2007-2017  
Part Number 44947

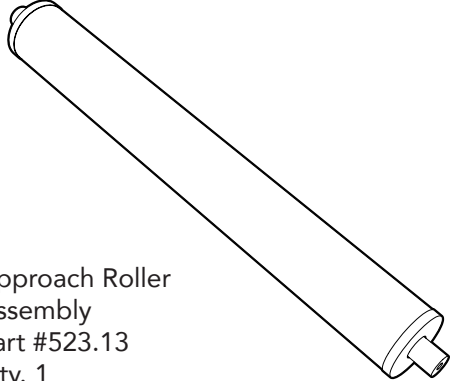
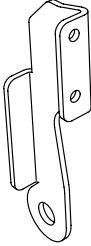
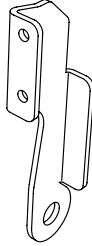
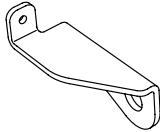
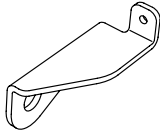
### Parts List

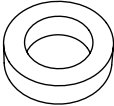
- Required parts for installation

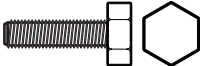
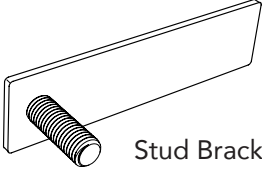





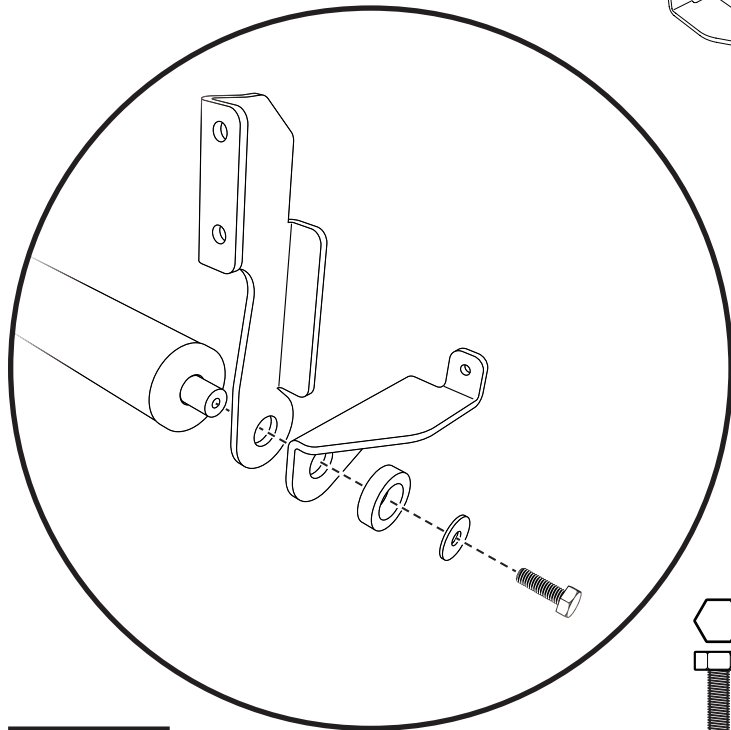

<b>Section 1</b>	<b>Approach Roller; Inner &amp; Outer Roller Brackets</b>	<b>Page 3 of Guide</b>
 <p>Approach Roller Assembly Part #523.13 Qty. 1</p>	<div style="border: 1px solid black; padding: 5px; background-color: #333; color: white; width: fit-content; margin: 0 auto;"> <b>Parts Bundle Part #563.39</b> </div> <div style="display: flex; justify-content: space-around; margin-top: 10px;"> <div style="text-align: center;">  <p>Right Inner Roller Bracket Part #522.32 Qty. 1</p> </div> <div style="text-align: center;">  <p>Left Inner Roller Bracket Part #522.31 Qty. 1</p> </div> </div>	<div style="border: 1px solid black; padding: 5px; background-color: #333; color: white; width: fit-content; margin: 0 auto;"> <b>Parts Bundle Part #563.40</b> </div> <div style="display: flex; justify-content: space-around; margin-top: 10px;"> <div style="text-align: center;">  <p>Right Outer Roller Bracket Part #522.34 Qty. 1</p> </div> <div style="text-align: center;">  <p>Left Outer Roller Bracket Part #522.33 Qty. 1</p> </div> </div>

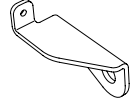
<b>Section 1</b>	<b>Fasteners - Some Will Be Pre-Assembled with the Roller</b>	<b>Page 3 of Guide</b>
<div style="border: 1px solid black; padding: 5px; background-color: #333; color: white; width: fit-content; margin: 0 auto;"> <b>Parts Bundle Part #563.41</b> </div>		
 <p>M10 Flat Washer Part #422.77 Qty. 2</p>	 <p>Roller Spacer Part #522.35 Qty. 2</p>	 <p>M8 Nylon Lock Nut Part #470.06 Qty. 2</p>
 <p>M10-1.5x30mm Hex Head Bolt Part #414.24 Qty. 2</p>	 <p>Stud Bracket Part #527.81 Qty. 2</p>	 <p>M8 Flat Washer Part #484.93 Qty. 2</p>

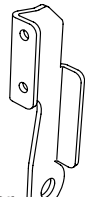
<b>Step 1</b>	522.31	522.32	522.33
	522.34	522.35	414.24
			422.77



**Hardware**

-  Right Outer Roller Bracket  
Part #522.34  
Qty. 1
-  Left Outer Roller Bracket  
Part #522.33  
Qty. 1
-  Right Inner Roller Bracket  
Part #522.32  
Qty. 1
-  Left Inner Roller Bracket  
Part #522.31  
Qty. 1
-  Roller Spacer  
Part #522.35  
Qty. 2
-  M10 Flat Washer  
Part #422.77  
Qty. 2
-  M10-1.5x30mm  
Hex Head Bolt  
Part #414.24  
Qty. 2
-  M8 Flat Washer  
Part #484.93  
Qty. 2
-  M8 Nylon  
Lock Nut  
Part #470.06  
Qty. 2

**Step 1**

**Front Bumper must be off the vehicle to perform this installation. The Winch Plate Must Stay attached to the Vehicle.**

Locate the Roller Assembly #523.13 and attach the Inner Roller Brackets #522.31 and #522.32, the Outer Roller Brackets #522.33 and #522.34, the Roller Spacer #522.35, the M10 Flat Washer #422.77, and the M10-1.5x30 Hex Head Bolt #414.24 in this order, from the roller outward.

Only tighten the bolts finger tight at this time.

Do this on both ends of the Roller.

**NOTE:**  
Bumper must be removed from the vehicle (NOT Winch Plate) to perform this installation

<b>Step 2</b>	527.81	522.33	522.34
---------------	--------	--------	--------

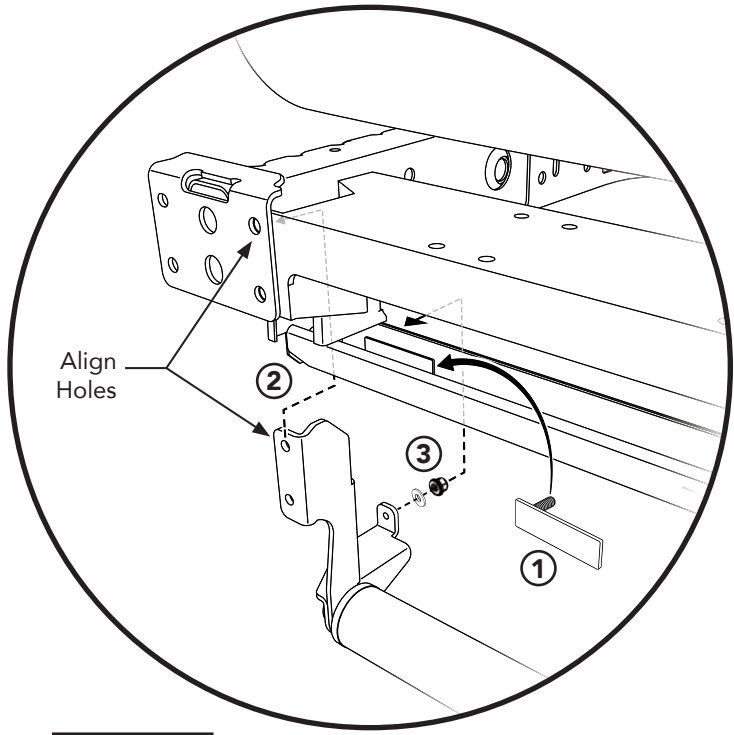

**Step 2**

- ① Place the Stud Brackets #527.81 inside the horizontal vehicle frame member, and insert the stud into the hole at each end of the horizontal frame member.
- ② Slide the Inner Roller Brackets up and behind the vehicle bumper mounting plates, making sure that the two holes in the Roller Bracket are aligned with the two inboard holes in each mounting plate.
- ③ Slide the rear tab of the Outer Right and Left Roller Brackets #522.33 and #522.34 onto the studs where they protrude from the back side of the horizontal frame member, and loosely secure the Outer Roller Brackets in place with one (1) M8 Nylon Lock Nut on each stud.

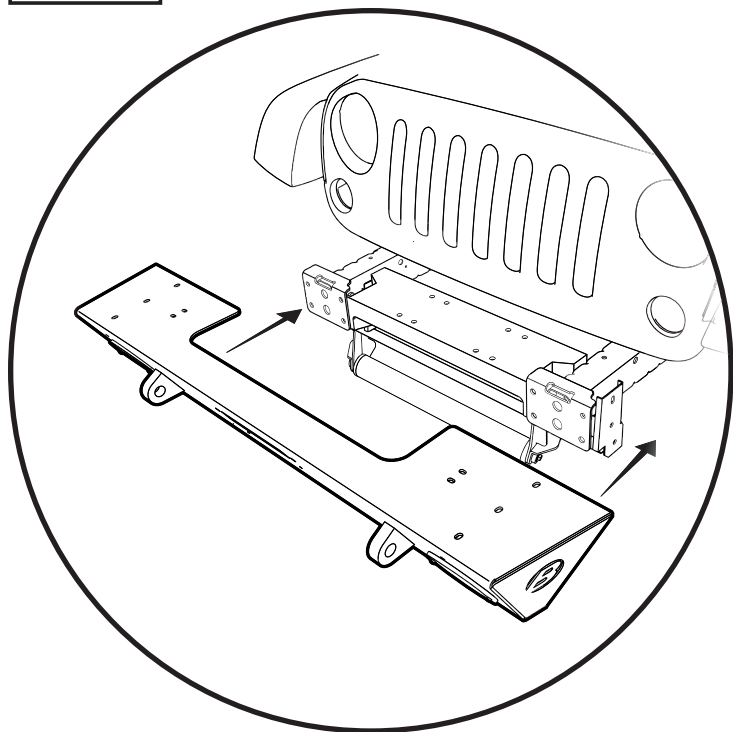
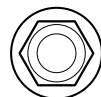
**Step 1****Hardware**

M10 Nylon Lock Nut  
Part #422.76  
Qty. 8

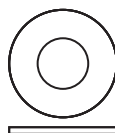
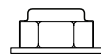

M10 Flat Washer  
Part #422.77  
Qty. 8

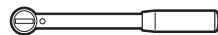
**Tools**

Socket Wrench



13mm Socket

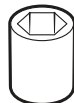

16mm Socket

**Step 1**

Re-Attach the Front Bumper. The studs on the inside of the Bumper will fit through the holes in the bumper mounting plates and through the holes in the Inner Roller Brackets.

Use the M10 Nylon Lock Nuts #422.76 and M10 Flat Washers #422.77 that you set aside when you removed the Bumper to secure the Bumper to the vehicle frame.

For additional instructions about attaching the Bumper, see the 44945 Installation Guide that came with your Bumper.

Tighten all fasteners at this time.



## Warranty Information Front Bumper Approach Roller

Vehicle Application:  
Jeep® Wrangler 2-Door & Unlimited 2007-2017  
Part Number 44947

### WHAT BESTOP WARRANTS

Subject to the terms and conditions of sale, including any terms and conditions set forth by Bestop, Inc. ("Bestop" or "us" or "we") in our then-current terms of sale on our website (collectively, the "Terms"), Bestop represents and warrants that: the covered products listed in the "Covered Products and Warranty Periods" section (a "Product") will substantially be free from defects in materials and workmanship for the specified warranty periods set forth in that section.

### THE WARRANTY IS LIMITED AND CONDITIONAL

This warranty applies to the original purchaser of the Product only. The warranty is valid only as long as the original retail purchaser owns the vehicle upon which the Product is installed. The warranty expires should the Product be removed from the original vehicle or if the original vehicle is transferred to another owner. This warranty is not transferable or assignable. The warranty does not apply to Product bought from auction-style or price-bid websites.

THE LIMITED WARRANTY AND STATED REMEDIES ARE SOLE AND EXCLUSIVE AND IN LIEU OF ALL OTHER WARRANTIES AND REMEDIES, AND COMPANY EXPRESSLY DISCLAIMS ALL IMPLIED OR STATUTORY OR OTHER WARRANTIES, INCLUDING WITHOUT LIMITATIONS WARRANTIES OF MERCHANTABILITY, NON-INFRINGEMENT OR FITNESS FOR A PARTICULAR PURPOSE. IN NO EVENT WILL COMPANY BE LIABLE FOR ANY SPECIAL, INCIDENTAL, CONSEQUENTIAL, PUNITIVE, INDIRECT OR EXEMPLARY DAMAGES OF ANY KIND, INCLUDING LOST PROFITS OR REVENUE, HOWEVER CAUSED, WHETHER FOR BREACH OR REPUDIATION OF CONTRACT, TORT, BREACH OF WARRANTY, NEGLIGENCE, OR OTHERWISE, WHETHER OR NOT COMPANY WAS ADVISED OF THE POSSIBILITY OF SUCH LOSS OR DAMAGES. *Some states do not allow exclusion or limitation, so this may not apply to you. This warranty gives you specific legal rights, and you may have other rights which vary from state to state.*

### EXCLUSIONS TO THE WARRANTY

The Limited Warranty excludes, and Bestop is not liable in any way for any warranty claims, damages, or defects related to:

- Misuse, abuse, accidents, vandalism, negligence, fire, or improper installation or modification, or improper or inadequate maintenance;
- Failure to comply with any Product documentation, Bestop instructions, or applicable law or regulations; use in extreme conditions
- Force Majeure including but not limited to, earthquake, hurricane, tornado, flooding, or other disasters natural or man-made, civil unrest, strikes, declared or undeclared war, or lack of performance by, or discontinued product of, supply chain partners whose products, software, operations or management is beyond the control of Bestop;
- Damage resulting in breakage (including without limitation, spontaneous breakage, accidental breakage or breakage by any other means) of a Product or any component part;
- Damage to vinyl windows due to misuse, or cracking due to varying weather conditions.

### YOUR SOLE REMEDY

During the applicable warranty period, Bestop shall, at its option, either repair or replace any Product that it confirms, in its discretion, is non-compliant with the warranties herein. Bestop will not pay for labor charges associated with installation or removal of the Product. Should a specific Product be discontinued, Bestop may, at its option, replace the discontinued Product with a current product or like product. If Bestop opts to repair or replace your Product as set forth herein, Bestop shall use reasonable efforts to match any patch or replacement to the color and texture of your existing Product. There is no guarantee however, that Bestop will be able to match the color or texture. If Bestop is not able to match the color or texture, it may provide you with a black or neutral colored patch replacement in its discretion.

Please retain your proof of purchase. Original proof of purchase for the Product must accompany any warranty claim. If you have a warranty claim, first you must email Bestop Customer Service at [csbestop@bestop.com](mailto:csbestop@bestop.com) for instructions. All claims must be emailed to [csbestop@bestop.com](mailto:csbestop@bestop.com) within 30 days of discovery of a defective Product, but in no event later than thirty days after the end of the applicable Warranty Period (the "Warranty Notice Period"). Warranty claims made after the Warranty Notice Period are null and void and Bestop shall have no responsibility with respect to such claims.

THIS SECTION SETS FORTH BESTOP'S SOLE OBLIGATION & YOUR SOLE REMEDY WITH RESPECT TO ANY DEFECTS OR OTHER PRODUCT ISSUE. ANY PRODUCTS REPLACED UNDER TERMS OF THIS WARRANTY WILL BE COVERED UNDER TERMS & BALANCE OF THE DURATION OF THE ORIGINAL LIMITED WARRANTY FOR SUCH PRODUCT.



## Warranty Information Front Bumper Approach Roller

Vehicle Application:  
Jeep® Wrangler 2-Door & Unlimited 2007-2017  
Part Number 44947

**COVERED PRODUCTS AND WARRANTY PERIODS:** The warranty time periods are as follows for Products manufactured by Bestop:

### **BESTOP® LIMITED LIFETIME WARRANTY**

Trektop® Pro Twill Fabric Top	Sunrider® for Hardtop Twill Fabric Top
Trektop® NX Glide Twill Fabric Top	Replace-a-Top™ Twill Fabric Top
Trektop® NX Twill Fabric Top	Supertop® NX Twill Fabric Top
EZFold™ Soft Tonneaus	Floor & Cargo Liners
ZipRail™ Soft Tonneaus	Pet Barriers
EZRoll™ Soft Tonneaus	

### **BESTOP® 5-YEAR LIMITED WARRANTY**

Trektop® NX Glide™ Top (non-Twill)	Sunrider® for Hardtop
(non-Twill)Replace-a-Top™ Top (non-Twill)	Trektop® NX Top (non-Twill)
Sailcloth Replace-a-Top™	Supertop® NX Top (non-Twill)
Tigertop™ and Halftop™	Supertop® Classic Soft Top
Sunrider® Complete Soft Top	Supertop® for Truck
EZ Fold Hard Tonneau	

### **BESTOP® 3-YEAR/100K MILES LIMITED WARRANTY**

Powerboard® & Powerboard® NX  
Trekstep®, Side Mount  
Trekstep®, Rear Mount

### **BESTOP® 3-YEAR LIMITED WARRANTY**

Pavement Ends Sprint Top

### **BESTOP® 2-YEAR LIMITED WARRANTY**

Trektop® Classic Soft Top  
RoughRider™ Soft Storage

### **BESTOP® 1-YEAR LIMITED WARRANTY**

All other Bestop® & Pavement Ends™ products not specified above.

**For further information or request for warranty work, please contact:**

**Bestop Inc. Customer Service**

**Toll-Free: (800)845-3567**

**Main: (303)465-1755**

**E-mail: [csbestop@Bestop.com](mailto:csbestop@Bestop.com)**

**Website: [www.Bestop.com](http://www.Bestop.com)**