



# Installation Instructions Modular Bumper - Front

Vehicle Application:  
Jeep® JL Wrangler & Gladiator 2018-Current  
Part Number 44955

## Installation Tips

Before you begin installing your new Modular Bumper, please read all the instructions thoroughly.









**WARNING** Do not rely in any way on the components of this product to protect against injury or death in the event of an accident. Never operate the vehicle in excess of manufacturer’s specifications.

Read and follow, precisely, all installation instructions provided when installing this product. Failure to do so may result in a poor fit and could place occupants of the vehicle in a potentially dangerous situation.

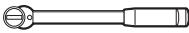

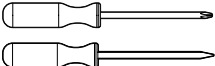
## WEAR SEAT BELTS AT ALL TIMES

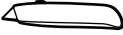
**CAUTION** Safety glasses should be worn at all times when installing this product.

Tools				Installation Time	Support
 Safety Glasses	 18mm - 3/8" Wrench	 Socket Wrench	 10mm - 15mm 16mm - 18mm 3/8" - 1/2" Sockets	 1-1/2 hours	We're here to help! Go to <a href="http://www.Bestop.com">www.Bestop.com</a> and click on "Contact Us"
 Phillips and Flat Blade Screwdrivers	 Wire Stripper- Crimper	 Pliers	 Utility Knife	<b>Skill Level</b>  3 - Moderately Difficult	



# Installation Instructions Modular Bumper - Front

Vehicle Application:  
Jeep® JL Wrangler & Gladiator 2018- Current  
Part Number 44955

## Parts List

- Required parts for installation

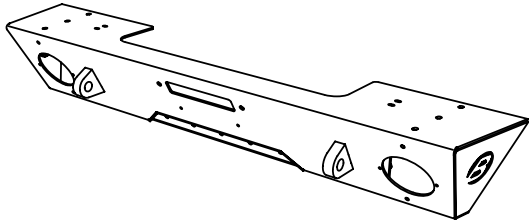
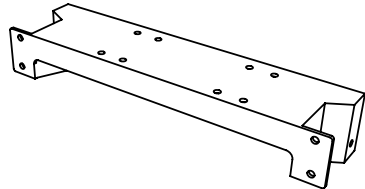
<b>Sections 2 to 8</b>		<b>Bumper, Winch Plate</b>	<b>Pages 5 to 12 of Guide</b>
	<p>Front Bumper Part #518.76 Qty. 1</p>		<p>Winch Plate Part #585.35 Qty. 1</p>

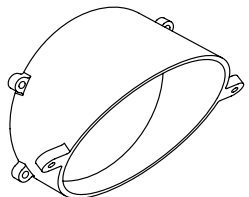
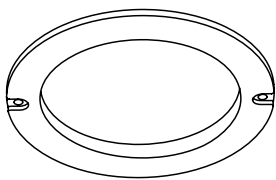
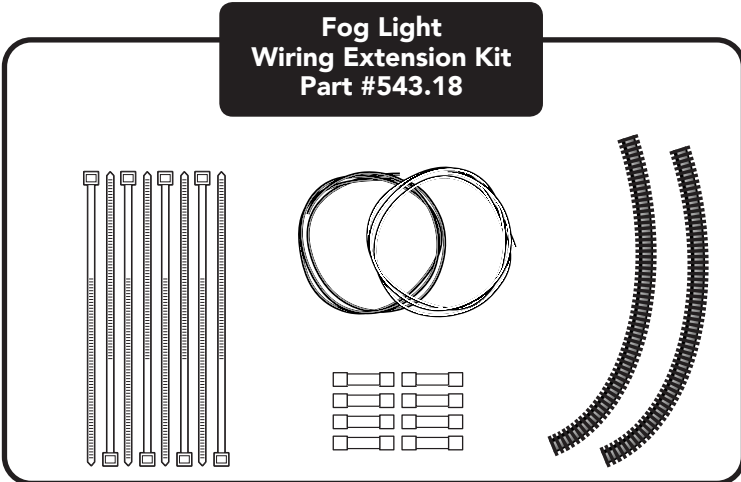
<b>Sections 2 to 8</b>		<b>Light Housings; Light Rings, Wiring Extension</b>	<b>Pages 5 to 12 of Guide</b>
	<p>Light Housing Part #479.20 Qty. 2</p>		<p>Light Ring Part #479.21 Qty. 2</p>
<div data-bbox="1207 990 1942 1469"><p><b>Fog Light Wiring Extension Kit Part #543.18</b></p></div>			



# Installation Instructions Modular Bumper - Front

Vehicle Application:  
Jeep® JL Wrangler & Gladiator 2018- Current  
Part Number 44955

## Parts List

- Required parts for installation

All Sections	Fastener Hardware	All Pages		
Fog Light Brackets Part #581.09 - Left Part #581.08 - Right Qty. 2 of each	M10 Nylon Lock Nut Part #422.76 Qty. 8	M10 Flat Washer Part #422.77 Qty. 8	Fender Washer Part #586.58 Qty. 12	M4 Flat Washer Part #539.67 Qty. 8
				#10x1" Pan Head Screw"/>
M4 Nylon Lock Nut Part #523.17 Qty. 8	M4 x 15mm Torx Screw Part #494.03 Qty. 8	#10 x 5/8" Screw Part #728670 Qty. 8	#12x1/2" Pan Head Screw Part #486.49 Qty. 8	#10x1" Pan Head Screw Part #486.51 Qty. 4

Step 1

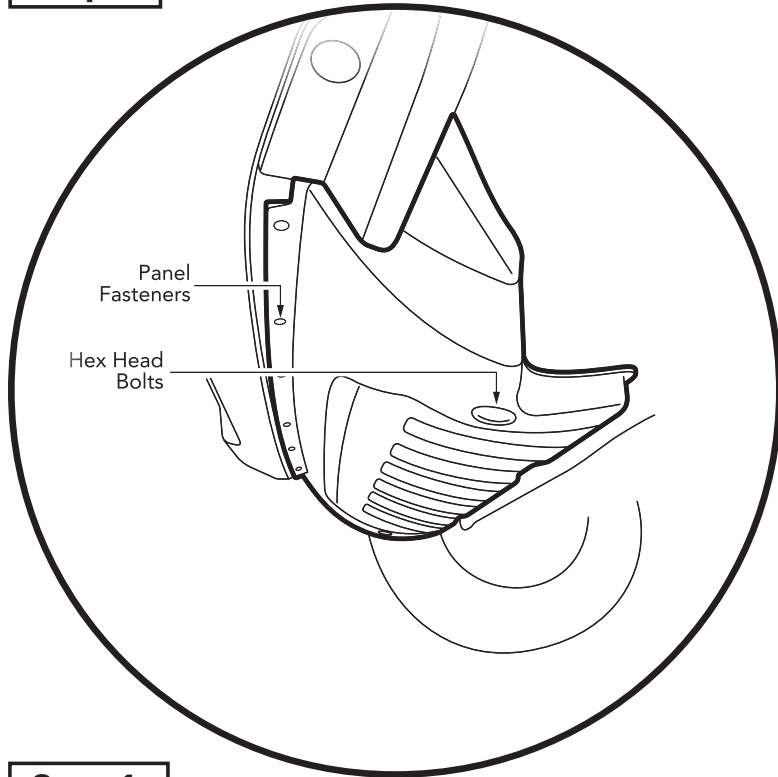

Tools

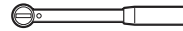

Socket Wrench



18mm & 7mm Sockets

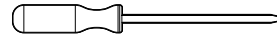

Flat Blade Screwdriver

Step 2



Step 1

Remove eight (8) Panel Fasteners and two (2) Hex-Head Bolts from the underside of the factory Skid Plate, and remove the Skid Plate from the Jeep.

Detail

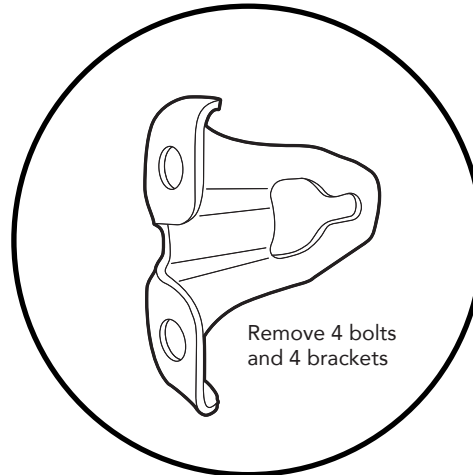

Step 2

**NOTE:** Unplug the Fog Light connector, located behind the bumper on the passenger side, before removing the factory bumper.

Remove eight (8) 18mm nuts attached to the studs on the inside of the bumper. These nuts attach the bumper to the Jeep frame.

Remove four (4) 16mm flanged hex head bolts and the four (4) attached brackets. See Detail of bracket. Keep these bolts for a later step in the installation.

**Step 1**

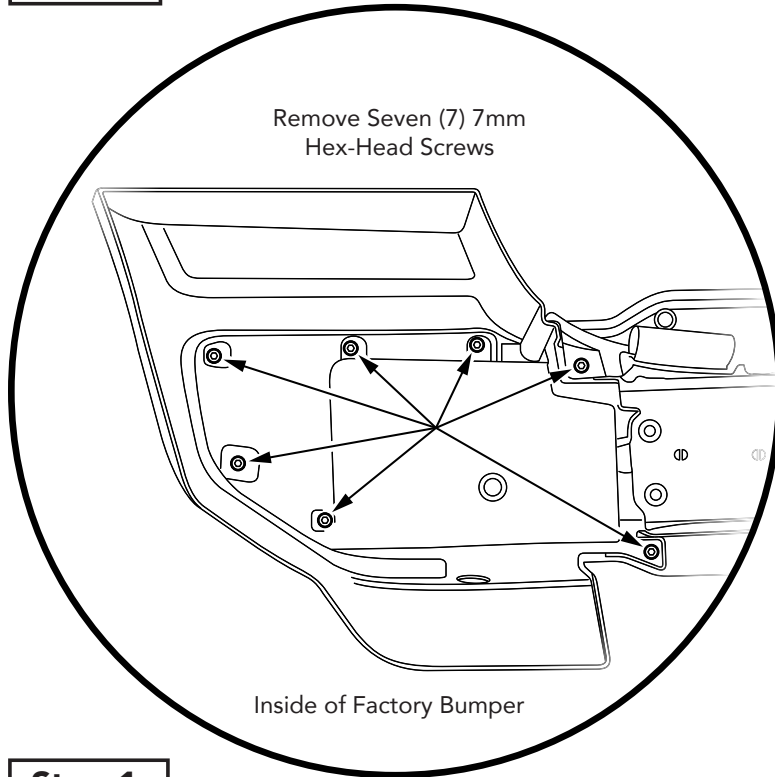

**Tools**

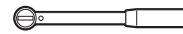

Socket Wrench



7mm Socket

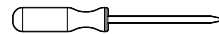

Flat Blade Screwdriver



T20 Torx Driver

**Step 2**

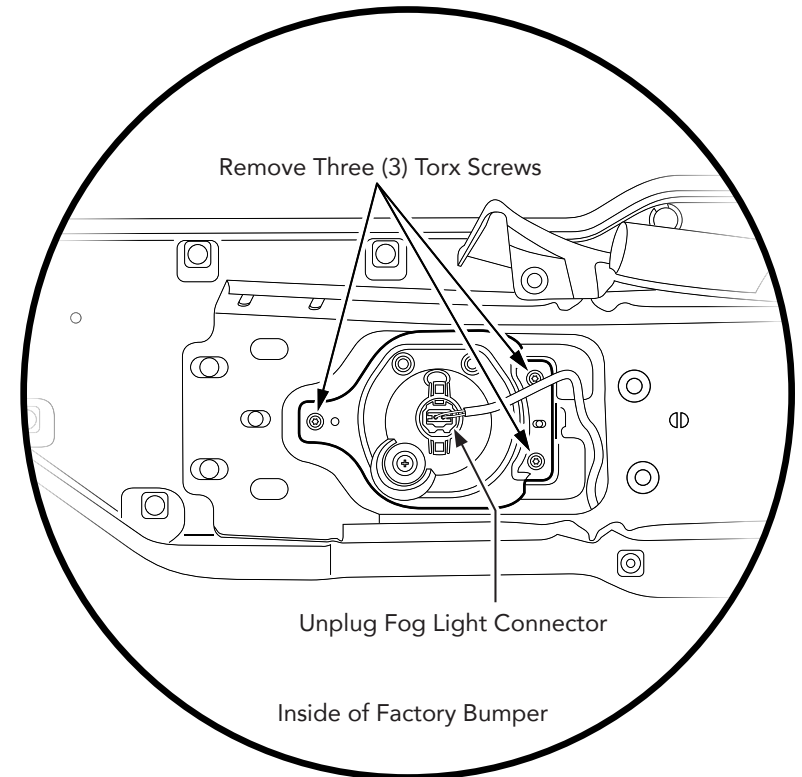

**Step 1**

Remove One (1) Panel Fastener and seven (7) Hex-Head Screws from the back side of the factory Bumper, and remove the Fog Light Rear Cover Panel.

Repeat for both Fog Lights.

**Step 2**

Remove three (3) T20 Torx Screws from the fog light bracket.

Unplug the Fog Light Connector.

Remove the Fog Light from the factory bumper.

Repeat for both Fog Lights.

**Step 1**

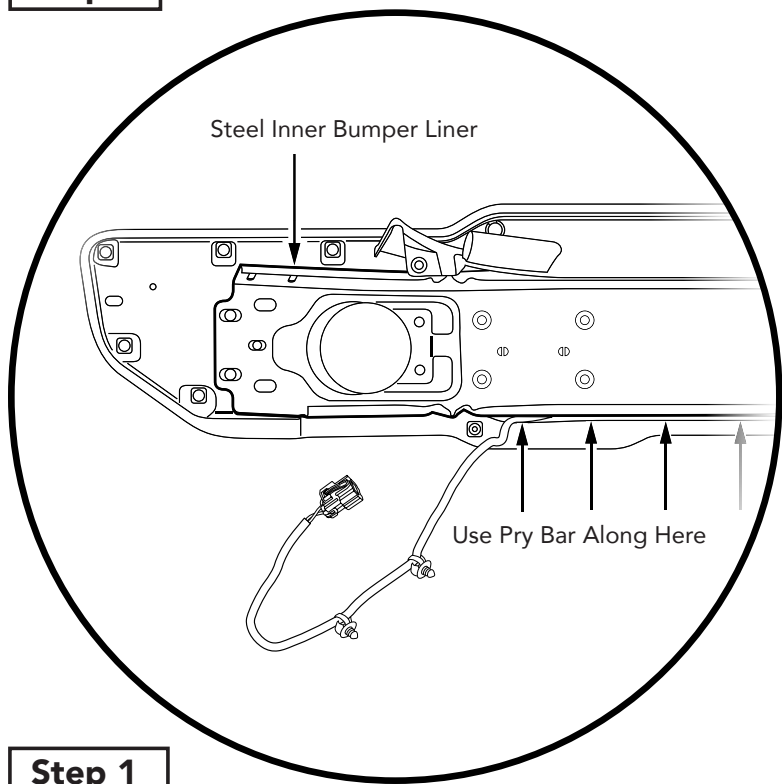

**Hardware**

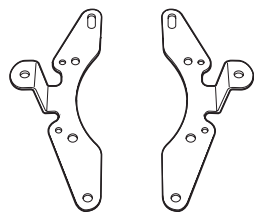

Fog Light Brackets  
Part #581.09 - Left  
Part #581.08 - Right  
Qty. 2 of each

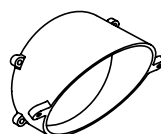

Fog Light Housing  
Part #479.20  
Qty. 2

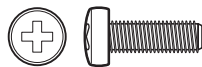

#10 x 5/8" Screw  
Part #728670  
Qty. 8

**Tools**

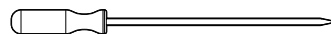

Long Flat-Blade Screwdriver



Pry Bar

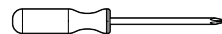

Phillips Screwdriver

**Step 2**

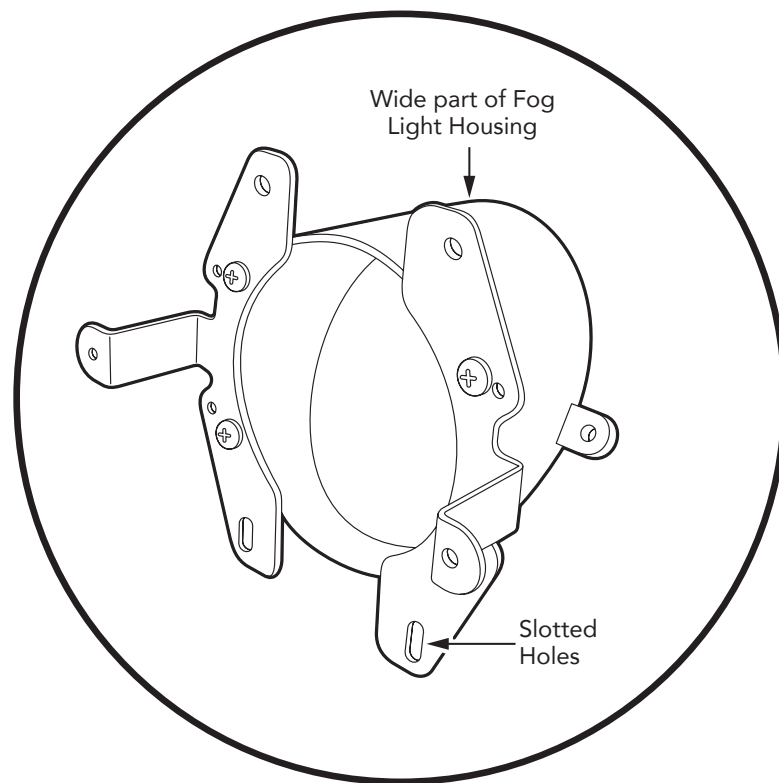

**Step 2**

Attach the Fog Light Brackets #581.08 and #581.09 to the Fog Light Housings #479.20.

Orient the Fog Light Housing with the wide part of the housing up, and attach the brackets as shown, with the slotted holes in the brackets on the bottom.

Attach the Brackets to the Housings using four (4) #10x5/8" #728670 Phillips Screws for each assembly.

**Step 1**



**WARNING**

This step is difficult. May take two people to accomplish and may damage the OEM bumper and wire harness.

From the back side of the factory bumper, use a pry bar to open a gap between the steel inner bumper liner and the plastic outer bumper fascia.

Use a long flat-blade screwdriver to pop out the seven (7) cable harness guides located between the bumper fascia and the liner, and remove the cable harness.

**OR** - you may order the factory OEM fog light wire harness from MOPAR. Part #6833 6461 AC

**Step 1**

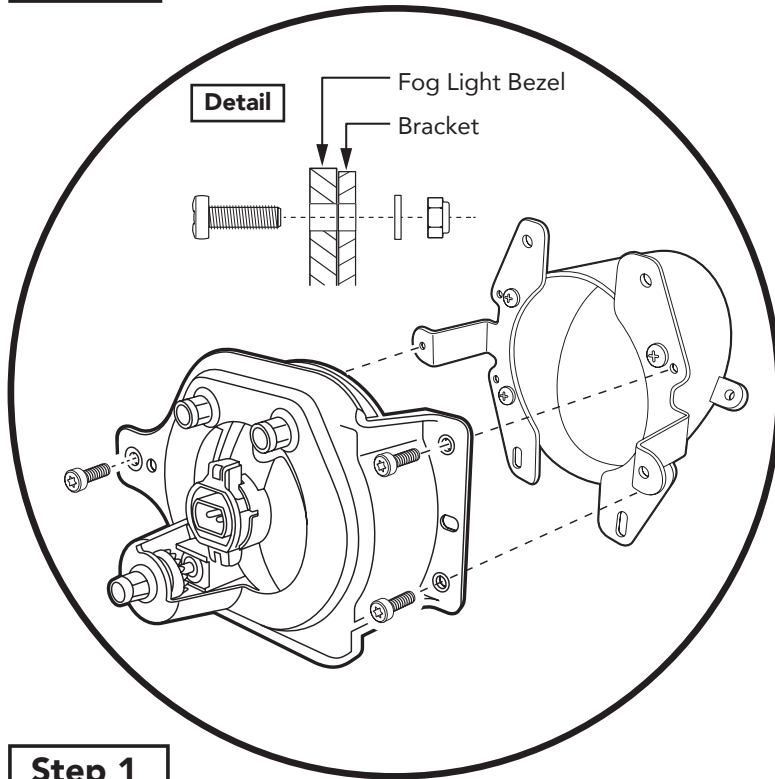

**Hardware**



M4 x 15mm  
Torx Screw  
Part #494.03  
Qty. 6



M4 Nylon Lock Nut  
Part #523.17  
Qty. 6



M4 Flat Washer  
Part #539.67  
Qty. 6

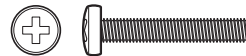

#10-24 x 1"  
Pan Head Screw  
Part #486.51  
Qty. 4



#10-24 Nylon Lock Nut  
Part #486.50  
Qty. 4

**Step 1**

Attach the Fog Lights to the Bracket-Housing Assemblies.

Use 3 three (3) M4x15mm Torx Screws #494.03, three (3) M4 Flat Washers #539.67, and three (3) M4 Nylon Lock Nuts #523.17 per assembly. See Detail.

**NOTE:** Fog Lights are marked with LH (driver side) and RH (passenger side). Lights are also marked with "Up". Wide part of Fog Light Housing is always at the top of the assembly.

Tabs on Light bezels go to the outside.

**Tools**

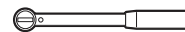

Socket  
Wrench



7mm  
Socket



T20 Torx  
Driver

**Step 1**

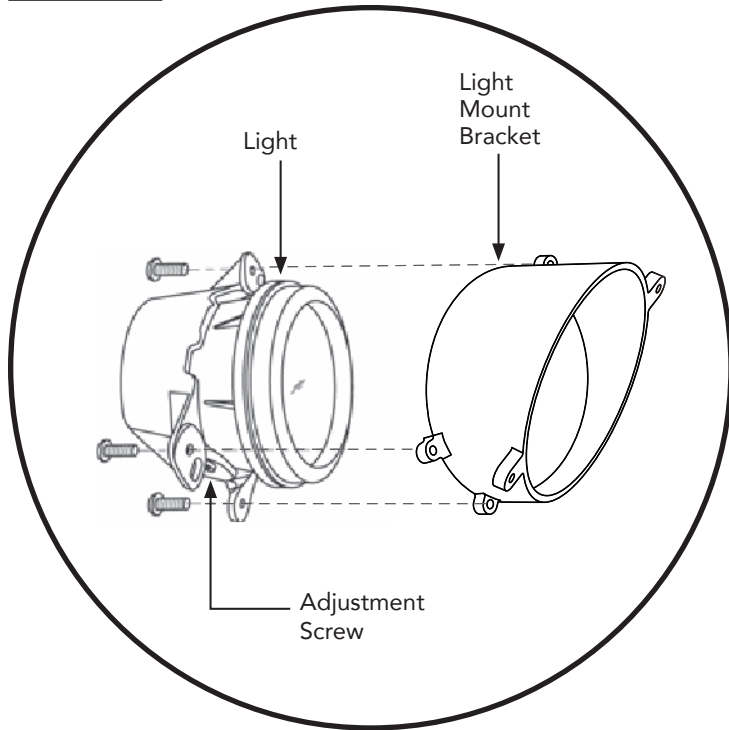

**Hardware**

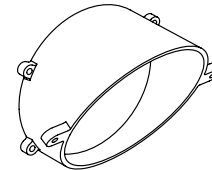

Light Housing  
Part #479.20  
Qty. 2

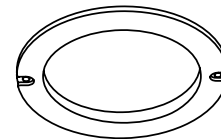

Light Ring  
Part #479.21  
Qty. 2

**Step 2**

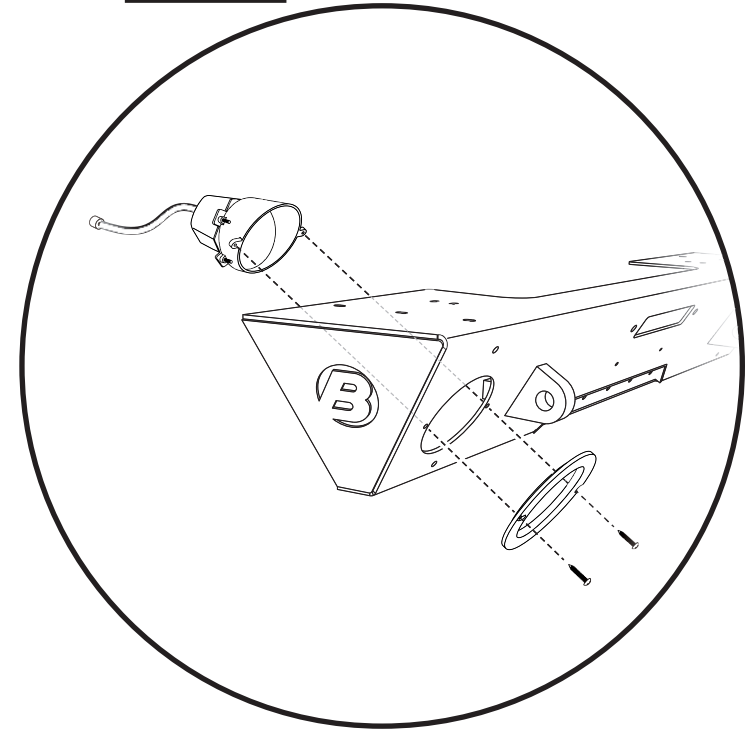

**Step 1**

Remove the fog lights from the original bumper.

Use four (4) #12 x 1/2" Pan Head Screws #486.49 on each light to attach the light to a Light Housing #479.20.

Make sure that the light adjustment screw is facing down (toward the thinner section of the Light Housing).



#12x1/2"  
Pan Head Screw  
Part #486.49  
Qty. 8

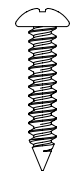

#10x1"  
Pan Head Screw  
Part #486.51  
Qty. 4

**Step 2**

Attach each light assembly to the Bumper, using one Light Ring #479.21 with two (2) #10x1" Pan Head Screws #486.51 per light assembly.



**Step 1** 585.35

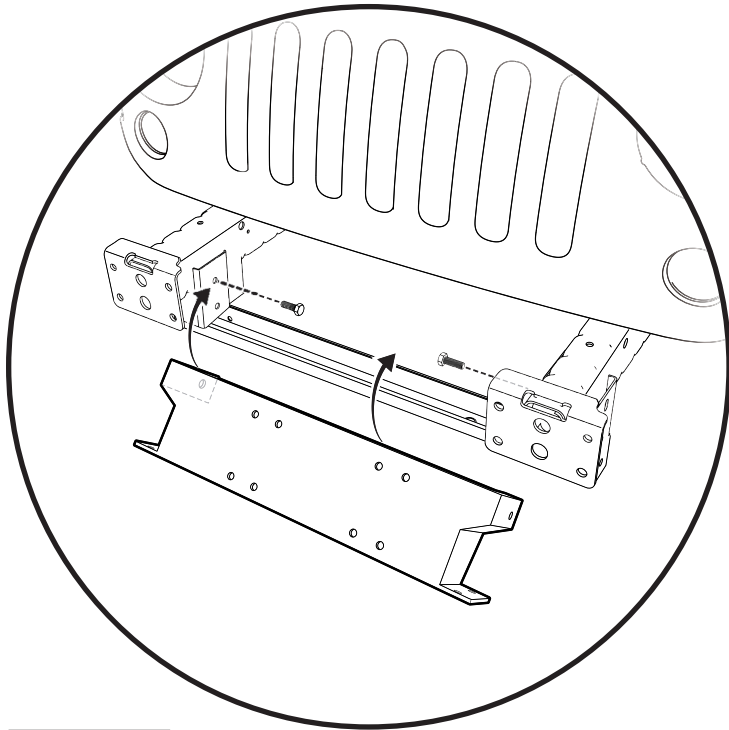

**Step 1**

① Slide the Winch Plate #585.35 in between the vehicle frame members from underneath, and then rotate the front part of the winch plate up and into place.

Align the holes in the Winch Plate with the holes in the vehicle frame members.

② Use two Flanged Hex Head Bolts removed when removing the factory bumper to loosely secure the Winch Plate in place - do not tighten these fasteners at this time.

You may need to use a hammer and a wood block to nudge the Winch Plate into place.

**Hardware**

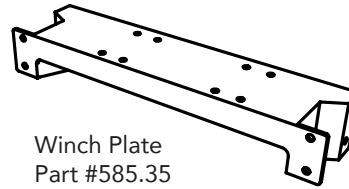

Winch Plate  
Part #585.35  
Qty. 1

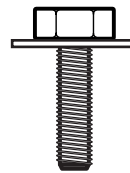

OEM Flanged Hex  
Bolts removed when  
removing OEM  
bumper.  
Qty. 2

**Tools**

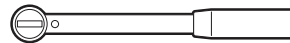

Socket wrench  
and 16mm  
socket

**Detail**

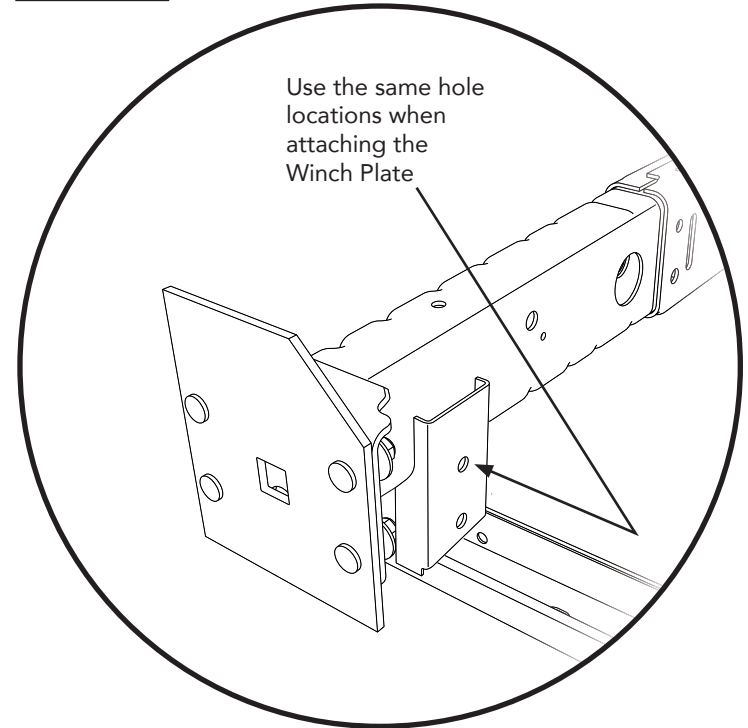

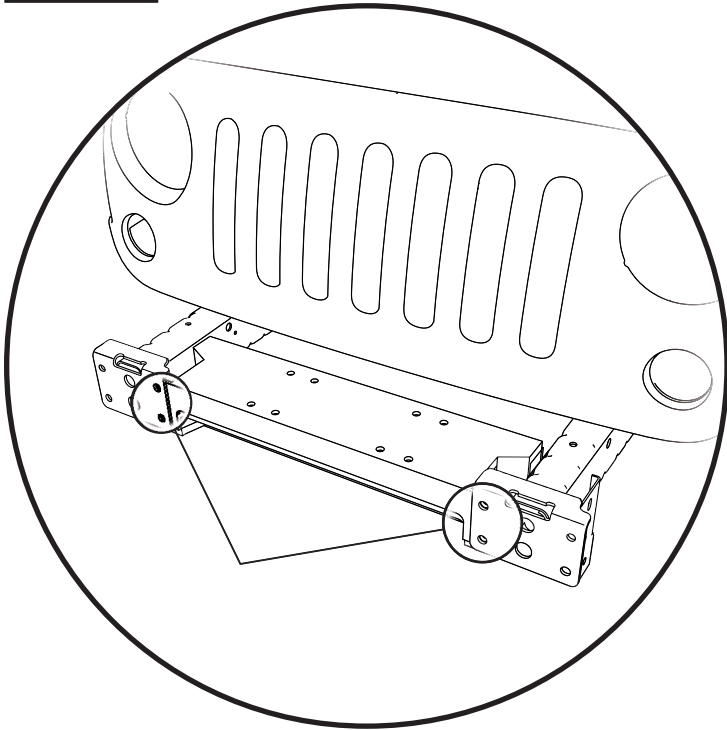
**Step 1****Step 1**

The Winch Plate will be in the correct position when the holes in the vehicle bumper mounting plates indicated above are aligned with the holes in the Winch Plate.

**Step 1** 518.76

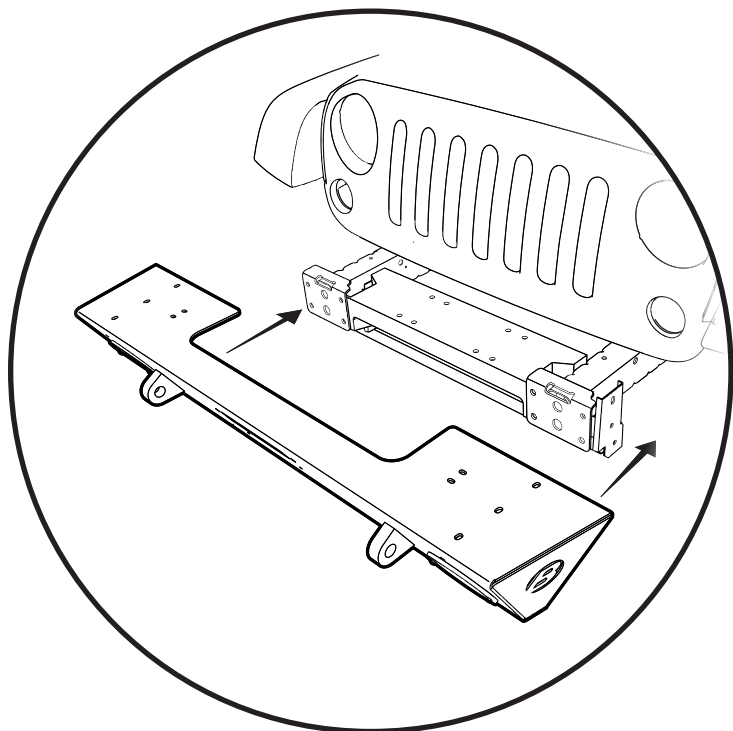

**Step 1**

Slide the Bumper onto the vehicle bumper mounting plates.

There are four (4) studs on each side of the bumper. These studs go through the four (4) holes in each bumper mounting plate.

**NOTE:** It may require two people to slide the Bumper into place.

**Hardware**

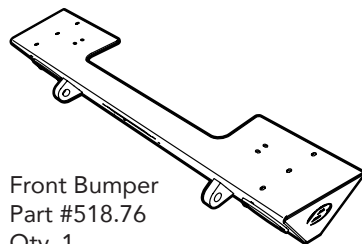

Front Bumper  
Part #518.76  
Qty. 1



M10 Nylon Lock Nut  
Part #422.76  
Qty. 10

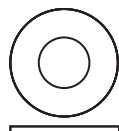

M10 Flat Washer  
Part #422.77  
Qty. 8

**Tools**

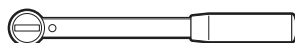

Socket wrench  
and 16mm  
socket

**Step 2** 422.76 422.77

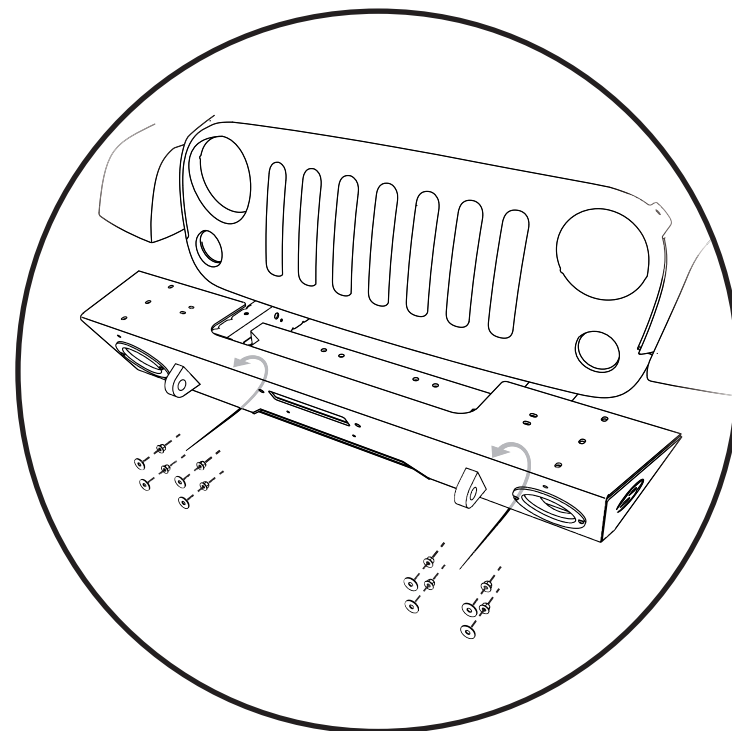

**Step 2**

Secure the Bumper to the vehicle bumper mounting plates with eight (8) M10 Nylon Lock Nuts #422.76 and eight (8) M10 Flat Washers #422.77.

Tighten all fasteners at this time.

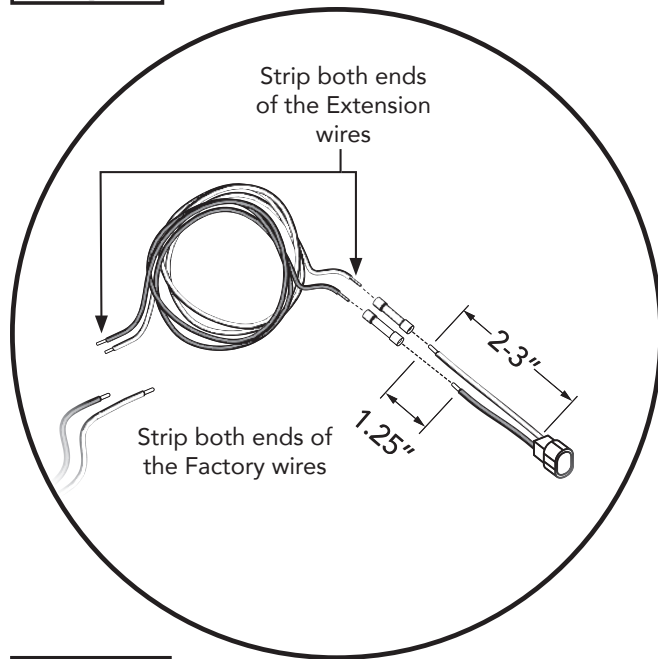
**Step 1****Step 1**

Cut the wires about 2-3" from the vehicle factory fog light connector.

It is suggested that you cut one wire about 1.25" longer than the other, to allow an easier fit into the wire wrap.

Strip both ends of the cut Factory wires.

Strip both ends of the extension wires in the Extension Kit #543.18.

**Hardware****Tools**

Utility Knife

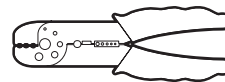

Wire Stripper-Crimper

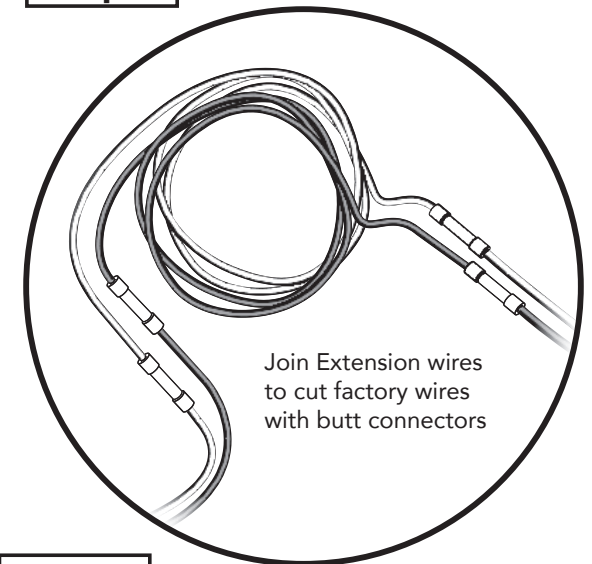
**Step 2****Step 2**

Crimp butt connectors to both stripped ends of the Extension wires.

Join the extension wires to the cut ends of the factory wires, crimping the ends together with the butt connectors.

- Black Extension wire attaches to the black factory wires
- White Extension wire attaches to white w/black stripe factory wire.

Cover the wire extensions with provided wire loom. Secure the loom with provided wire ties or electrical tape.

Repeat on both sides of the vehicle.

Connect the extended wires with factory plugs to the fog lights and check for proper function.



## Warranty Information Modular Bumper - Front

Vehicle Application:  
Jeep® JL Wrangler & Gladiator 2018-Current  
Part Number 44955

### WHAT BESTOP WARRANTS

Subject to the terms and conditions of sale, including any terms and conditions set forth by Bestop, Inc. ("Bestop" or "us" or "we") in our then-current terms of sale on our website (collectively, the "Terms"), Bestop represents and warrants that: the covered products listed in the "Covered Products and Warranty Periods" section (a "Product") will substantially be free from defects in materials and workmanship for the specified warranty periods set forth in that section.

### THE WARRANTY IS LIMITED AND CONDITIONAL

This warranty applies to the original purchaser of the Product only. The warranty is valid only as long as the original retail purchaser owns the vehicle upon which the Product is installed. The warranty expires should the Product be removed from the original vehicle or if the original vehicle is transferred to another owner. This warranty is not transferable or assignable. The warranty does not apply to Product bought from auction-style or price-bid websites.

THE LIMITED WARRANTY AND STATED REMEDIES ARE SOLE AND EXCLUSIVE AND IN LIEU OF ALL OTHER WARRANTIES AND REMEDIES, AND COMPANY EXPRESSLY DISCLAIMS ALL IMPLIED OR STATUTORY OR OTHER WARRANTIES, INCLUDING WITHOUT LIMITATIONS WARRANTIES OF MERCHANTABILITY, NON-INFRINGEMENT OR FITNESS FOR A PARTICULAR PURPOSE. IN NO EVENT WILL COMPANY BE LIABLE FOR ANY SPECIAL, INCIDENTAL, CONSEQUENTIAL, PUNITIVE, INDIRECT OR EXEMPLARY DAMAGES OF ANY KIND, INCLUDING LOST PROFITS OR REVENUE, HOWEVER CAUSED, WHETHER FOR BREACH OR REPUDIATION OF CONTRACT, TORT, BREACH OF WARRANTY, NEGLIGENCE, OR OTHERWISE, WHETHER OR NOT COMPANY WAS ADVISED OF THE POSSIBILITY OF SUCH LOSS OR DAMAGES. *Some states do not allow exclusion or limitation, so this may not apply to you. This warranty gives you specific legal rights, and you may have other rights which vary from state to state.*

### EXCLUSIONS TO THE WARRANTY

The Limited Warranty excludes, and Bestop is not liable in any way for any warranty claims, damages, or defects related to:

- Misuse, abuse, accidents, vandalism, negligence, fire, or improper installation or modification, or improper or inadequate maintenance;
- Failure to comply with any Product documentation, Bestop instructions, or applicable law or regulations; use in extreme conditions
- Force Majeure including but not limited to, earthquake, hurricane, tornado, flooding, or other disasters natural or man-made, civil unrest, strikes, declared or undeclared war, or lack of performance by, or discontinued product of, supply chain partners whose products, software, operations or management is beyond the control of Bestop;
- Damage resulting in breakage (including without limitation, spontaneous breakage, accidental breakage or breakage by any other means) of a Product or any component part;
- Damage to vinyl windows due to misuse, or cracking due to varying weather conditions.

### YOUR SOLE REMEDY

During the applicable warranty period, Bestop shall, at its option, either repair or replace any Product that it confirms, in its discretion, is non-compliant with the warranties herein. Bestop will not pay for labor charges associated with installation or removal of the Product. Should a specific Product be discontinued, Bestop may, at its option, replace the discontinued Product with a current product or like product. If Bestop opts to repair or replace your Product as set forth herein, Bestop shall use reasonable efforts to match any patch or replacement to the color and texture of your existing Product. There is no guarantee however, that Bestop will be able to match the color or texture. If Bestop is not able to match the color or texture, it may provide you with a black or neutral colored patch replacement in its discretion.

Please retain your proof of purchase. Original proof of purchase for the Product must accompany any warranty claim. If you have a warranty claim, first you must email Bestop Customer Service at [csbestop@bestop.com](mailto:csbestop@bestop.com) for instructions. All claims must be emailed to [csbestop@bestop.com](mailto:csbestop@bestop.com) within 30 days of discovery of a defective Product, but in no event later than thirty days after the end of the applicable Warranty Period (the "Warranty Notice Period"). Warranty claims made after the Warranty Notice Period are null and void and Bestop shall have no responsibility with respect to such claims.

THIS SECTION SETS FORTH BESTOP'S SOLE OBLIGATION & YOUR SOLE REMEDY WITH RESPECT TO ANY DEFECTS OR OTHER PRODUCT ISSUE. ANY PRODUCTS REPLACED UNDER TERMS OF THIS WARRANTY WILL BE COVERED UNDER TERMS & BALANCE OF THE DURATION OF THE ORIGINAL LIMITED WARRANTY FOR SUCH PRODUCT.



## Warranty Information Modular Bumper - Front

Vehicle Application:  
Jeep® JL Wrangler & Gladiator 2018-Current  
Part Number 44955

**COVERED PRODUCTS AND WARRANTY PERIODS:** The warranty time periods are as follows for Products manufactured by Bestop:

### BESTOP® LIMITED LIFETIME WARRANTY

Trektop® Pro Twill Fabric Top	Sunrider® for Hardtop Twill Fabric Top
Trektop® NX Glide Twill Fabric Top	Replace-a-Top™ Twill Fabric Top
Trektop® NX Twill Fabric Top	Supertop® NX Twill Fabric Top
EZFold™ Soft Tonneaus	Floor & Cargo Liners
ZipRail™ Soft Tonneaus	Pet Barriers
EZRoll™ Soft Tonneaus	

### BESTOP® 5-YEAR LIMITED WARRANTY

Trektop® NX Glide™ Top (non-Twill)	Sunrider® for Hardtop
(non-Twill) Replace-a-Top™ Top (non-Twill)	Trektop® NX Top (non-Twill)
Sailcloth Replace-a-Top™	Supertop® NX Top (non-Twill)
Tigertop™ and Halftop™	Supertop® Classic Soft Top
Sunrider® Complete Soft Top	Supertop® for Truck
EZ Fold Hard Tonneau	

### BESTOP® 3-YEAR/100K MILES LIMITED WARRANTY

Powerboard® & Powerboard® NX  
Trekstep®, Side Mount  
Trekstep®, Rear Mount

### BESTOP® 3-YEAR LIMITED WARRANTY

Pavement Ends Sprint Top

### BESTOP® 2-YEAR LIMITED WARRANTY

Trektop® Classic Soft Top  
RoughRider™ Soft Storage

### BESTOP® 1-YEAR LIMITED WARRANTY

All other Bestop® & Pavement Ends™ products not specified above.

**For further information or request for warranty work, please contact:**

**Bestop Inc. Customer Service**

**Toll-Free: (800)845-3567**

**Main: (303)465-1755**

**E-mail: [csbestop@Bestop.com](mailto:csbestop@Bestop.com)**

**Website: [www.Bestop.com](http://www.Bestop.com)**