



BESTOP

YJ Tinted Window Kit Installation Instructions

For: Wrangler/YJ 1988 - 1995

Part Number: 58120

WARNING

This product is designed to enhance the appearance of the vehicle and to shield the occupants from ordinary weather conditions. The safety characteristics of this product are extremely limited. Do not rely in any way on the components of this product to contain occupants within the vehicle, or to protect against injury or death in the event of an accident. This product will not protect the occupants from falling objects. Never operate vehicle in excess of manufacturer's specifications.

WEAR SEAT BELTS AT ALL TIMES

Read and follow, precisely, all installation instructions provided when installing. Failure to do so may result in a poor fit and could place occupants of the vehicle in a potentially dangerous situation.

Installation Tips

Before you begin installing this product read all instructions thoroughly. After completing the installation, keep these instructions for further reference. Below are a few tips to make this installation easier.

For a smooth fit:

For ease in installation, this product should be installed at temperatures above 72° F. Below this temperature, the fabric may contract an inch or more, making it difficult to fit to the vehicle.

It is normal for the fabric to contract and wrinkle when stored in the shipping carton. Within a few days after the installation, the fabric will relax and the wrinkles will disappear.

Parts Kit

Quarter Window, Right	Qty - 1
Quarter Window, Left	Qty - 1
Rear Curtain (Window)	Qty - 1

Step One

Start the zippers 2-3 inches on the top and rear of the side curtain.

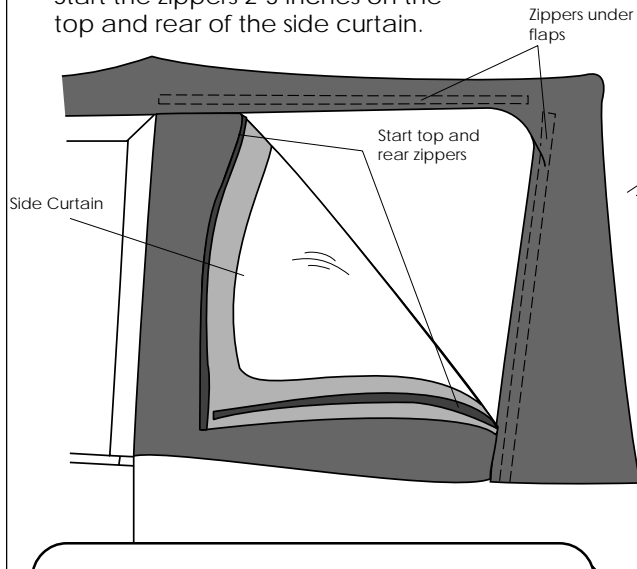

Note: It may be easier to install the Side Curtains with the spreader bar pulled down.

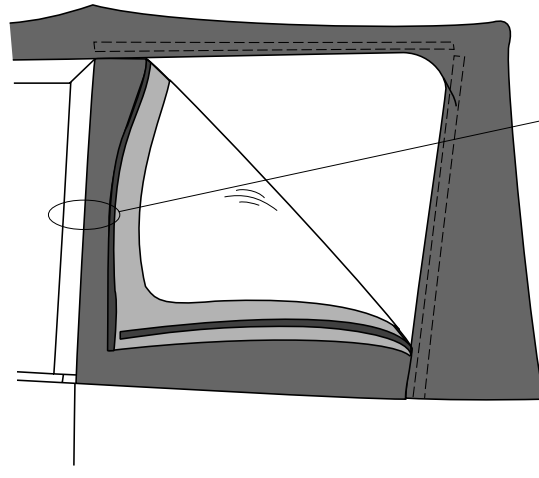
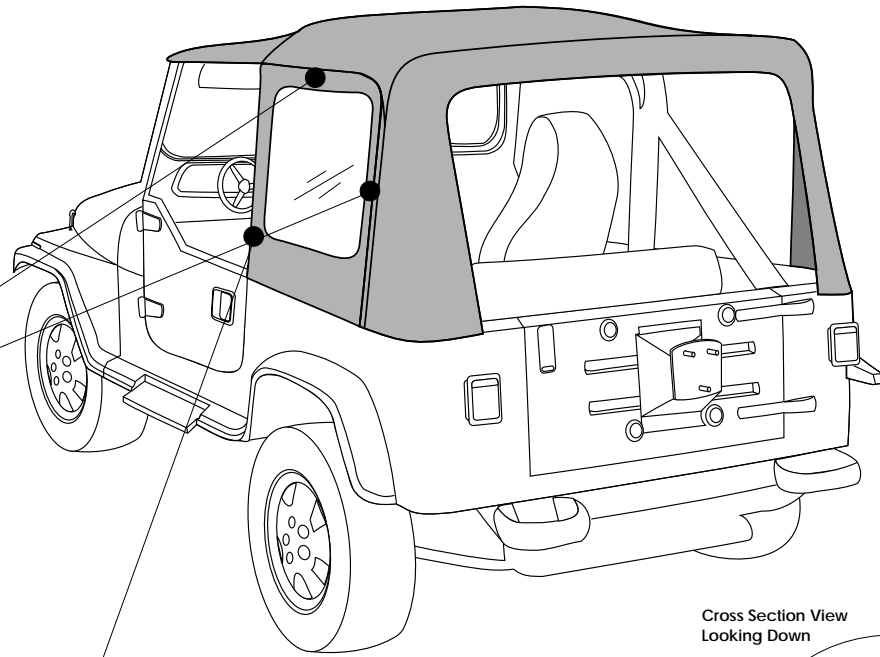

Step Two

Pop the plastic strip on the front of the side curtain into the retainer channel on the front support bow.

Cross Section View Looking Down

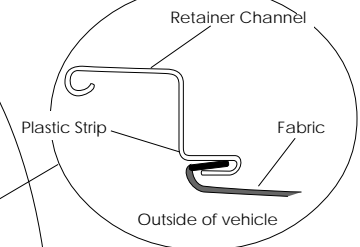

Plastic Strip into Retainer Channel

View of Side Curtain from Front

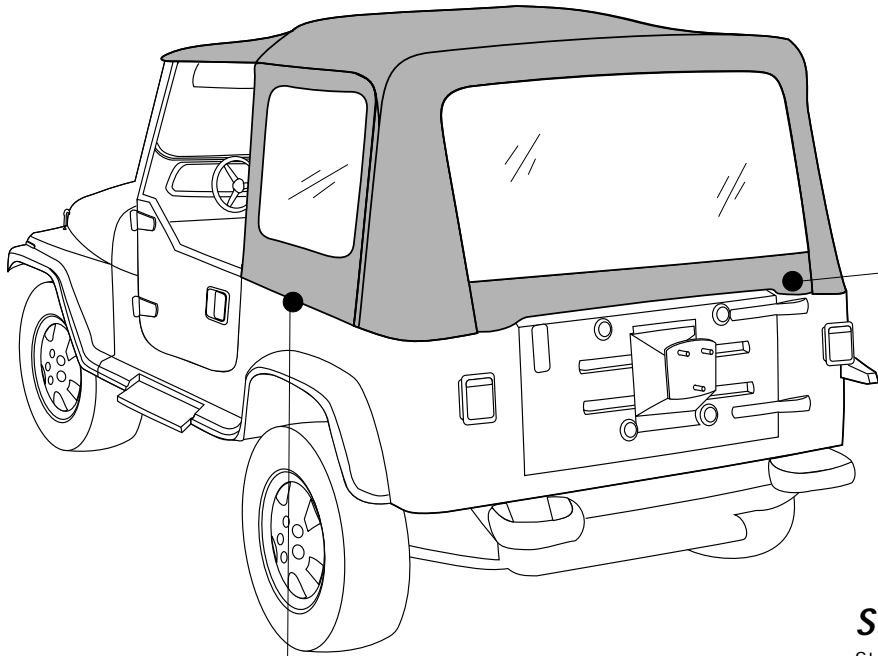

Slip Plastic Strip into Tailgate Retainer

Rear Curtain

Tailgate must be open

Tailgate Retainer

Rear Curtain Retainer

Slide Rear Curtain Retainer onto Rear Curtain. Push Rear Curtain Retainer into top of Tailgate Retainer.

Step Three

Slip the plastic strip on the bottom of the side curtain into the side retainer. Close the top and rear zippers on the side curtain.

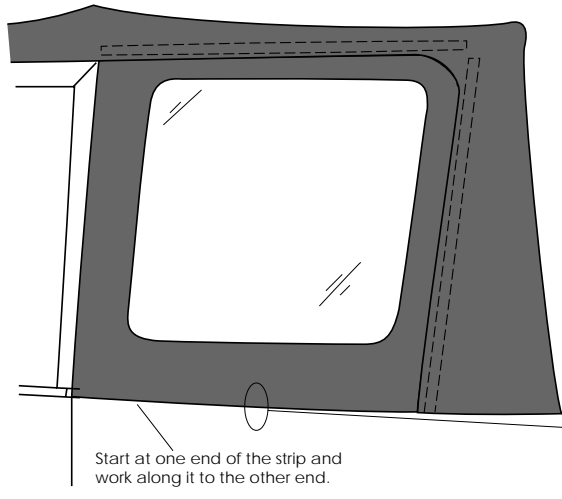

Start at one end of the strip and work along it to the other end.

Step Four

Start the zippers 2-3 inches on the top and sides of the rear curtain.

Open the tailgate. Slide the rear curtain retainer onto the bottom of the rear curtain. Close the rear curtain zippers. Push the rear curtain retainer into the top of the tailgate retainer. Slip the plastic on the bottom of the corners under the bottom of the tailgate retainer.

Side Retainer

Fabric

Plastic Strip

Rear Curtain Retainer

Rear Curtain Fabric

Tailgate Retainer

Plastic Strip

Step Five

Push the spreader bars up into the horizontal position.

Warning: When operating the vehicle without the Quarter Windows, the Rear Curtain should be rolled up for proper ventilation.

Adjusting the Top

Quarter Windows

To remove the Quarter Windows, unzip the rear and top zippers. Release the plastic strip from the retainer. Release the Hook and Loop Fasteners from around the Vertical Retainer.

Rear Curtain

To roll up the Rear Curtain, unzip the side zippers. Remove the Tailgate Bar and start to roll the curtain at the bottom, rolling it to the inside. Avoid wrinkles in the fabric and window. Secure it in place with the curtain straps inside of the top.

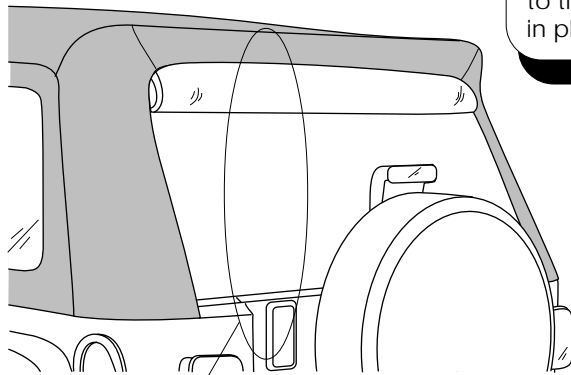

Detail of Rear Curtain

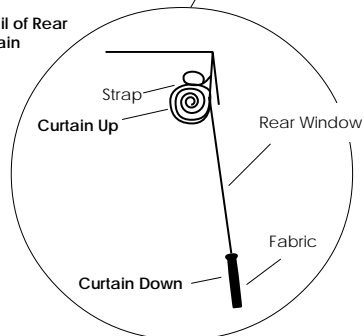

Side View

Care and Maintenance of your Bestop Top

Your top is made of the finest materials available. To keep it looking new and for the maximum possible wear, it will need periodic cleaning and maintenance.

Washing: The top fabric should be washed often using soap, warm water and a soft bristle brush. Rinse with clear water to remove all traces of soap.

Windows: Keep windows clean to avoid scratching. DO NOT use a brush on the windows! Wash with a watersoaked cloth or sponge and a mild dishwashing detergent. NEVER WIPE THE WINDOWS WHEN THEY ARE DRY. Be careful when cleaning snow or frost from the vinyl windows since they are easily scratched and may crack at low temperatures. DO NOT roll the sides or rear window in cold weather. The windows become stiff and will crack.

Zippers: Keeping the zipper cleaned and lubricated with a silicone lubricant will help prevent damage and keep the zippers in a smooth working condition. If a zipper opens behind the slider, the slider may have been spread apart. This problem can usually be repaired by using an ordinary pair of pliers to bring the sides back into parallel. Return slider to the end of the zipper in the normal Open position. Squeeze lightly at first and test the zipper. If the zipper continues to remain open squeeze more firmly with the pliers and try the zipper again. Repeat this procedure until the zipper operates correctly.

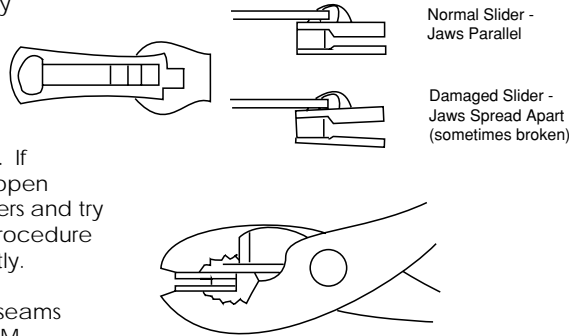

Water: Seeping through at the seams may be stopped by applying 3-M Scotchgard® on the inside of the seams. Rips in the fabric may be repaired with Bondex® iron on patches. Iron the patches to the Inside of the top, carefully following the Bondex® instructions.

Snaps: Keep snaps cleaned and lubricated with silicone to help prevent snaps from sticking to the studs. If a snap does become stuck to a stud, use a screwdriver and GENTLY pry apart to prevent permanent damage to the snap or the top fabric.

LIMITED WARRANTY

We warrant our product to be free from defects in material and workmanship, for the terms specified below, provided there has been normal use and proper maintenance. This warranty applies to the original purchaser only. All remedies under this warranty are limited to the repair or replacement of any item or items found by the factory to be defective within the time period specified.

If you have a warranty claim, first you must call our factory at the number below for instructions. You must retain proof of purchase and submit a copy with any items returned for warranty work. Upon completion of warranty work, if any, we will return the repaired or replaced item or items to you freight prepaid. Damage to our products caused by accidents, fire, vandalism, negligence, misinstallation, misuse, Acts of God, or by defective parts not manufactured by us, is not covered under this warranty.

THE WARRANTY TIME PERIOD IS AS FOLLOWS: ALL "SOFT GOODS" MANUFACTURED BY OUR COMPANY (USING PRIMARILY VINYL, PLASTICS, AND/OR FOAM): ONE YEAR FROM DATE OF PURCHASE.

ANY IMPLIED WARRANTIES OF MERCHANTABILITY AND/OR FITNESS FOR A PARTICULAR PURPOSE CREATED HEREBY ARE LIMITED IN DURATION TO THE SAME DURATION AND SCOPE AS THE EXPRESS WRITTEN WARRANTY. OUR COMPANY SHALL NOT BE LIABLE FOR ANY INCIDENTAL OR CONSEQUENTIAL DAMAGE.

Some states do not allow limitations on how long an implied warranty lasts, or the exclusion or limitation of incidental or consequential damages, so the above limitations or exclusions may not apply to you.

This warranty gives you specific legal rights, and you may also have other rights which vary from state to state.

For further information or request for warranty work, please contact:

Bestop Inc.
Customer Service
(800)346-3910
(303)465-1755