







Installation Instructions TrekStep Side-Mount™

Vehicle Application

- Dodge 1500
2009 – Current
Part Number: 75406-15

www.bestop.com - We're here to help! Visit our web site and click on "Ask a Question". Click here for more [Truck Accessories by Bestop](#).

INSTALLATION TIME  1/2 Hour	SKILL LEVEL  1 - Easy			
TOOLS				
 Ratchet	 Extension	 Socket 13 mm and 17 mm	 Allen Wrench 8 mm, 3/16"	 Safety Glasses



⚠ WARNING Do not rely in any way on the components of this product to protect against injury or death in the event of an accident. Never operate the vehicle in excess of manufacturer's specifications.

WEAR SEAT BELTS AT ALL TIMES

Read and follow, precisely, all installation instructions provided when installing product. Failure to do so may result in a poor fit and could place occupants of the vehicle in a potentially dangerous situation.

TrekStep Side-Mount™ – Installation Instructions

Parts List and Hardware Identification

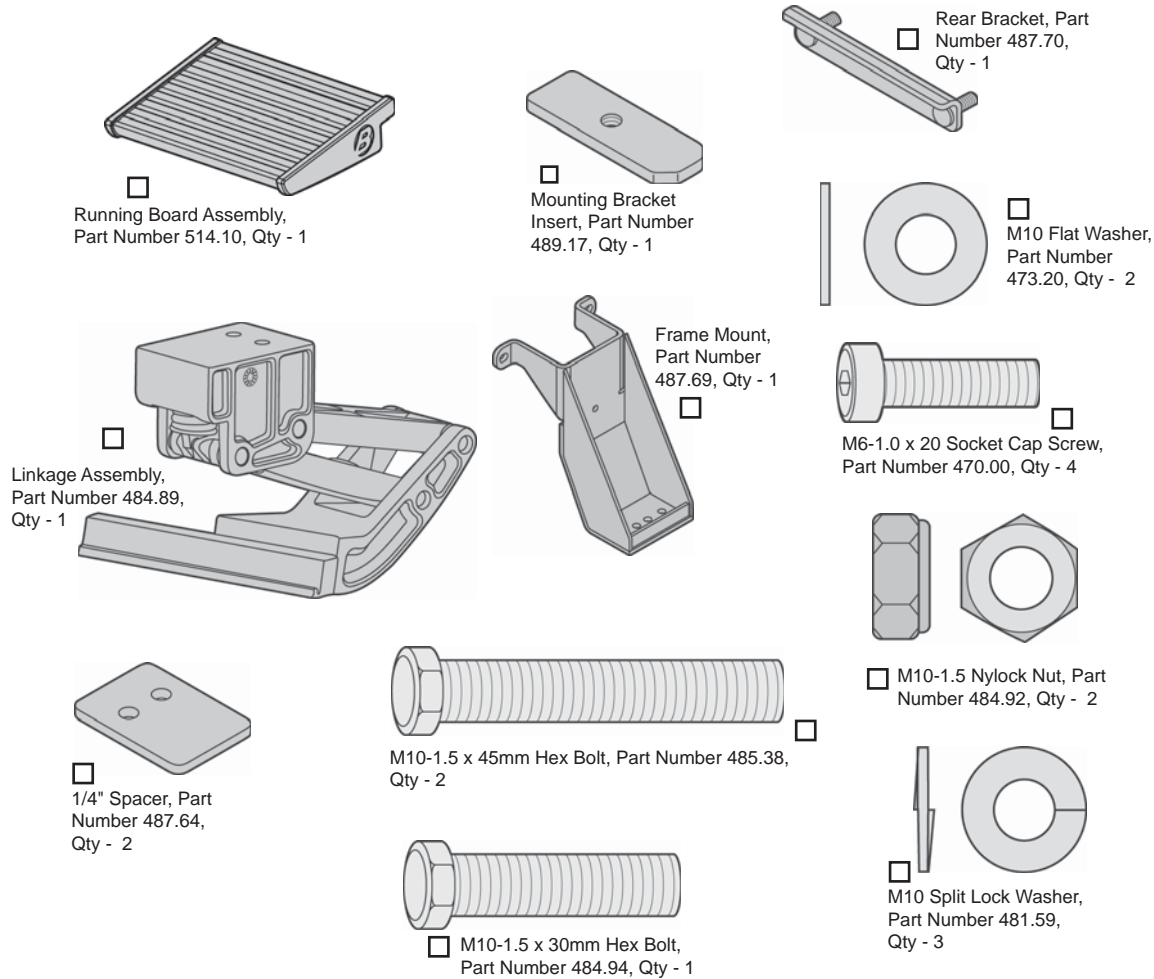

1 Mount Insert on Frame Mount

Use the M10-1.5 x 30mm Hex Bolt and M10 Split Lock Washer to install the Mounting Bracket Insert on the Frame Mount. Leave the assembly loose.

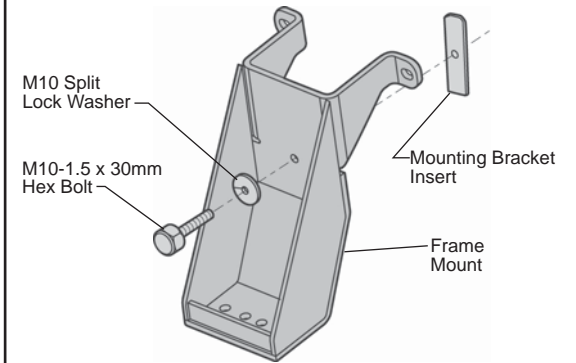

2 Install Linkage on Frame Mount Assembly

Use the two (2) M10-1.5 x 45mm Hex Bolts and M10 Split Lock Washers to secure the Linkage to the rear holes in the Frame Mount Assembly.

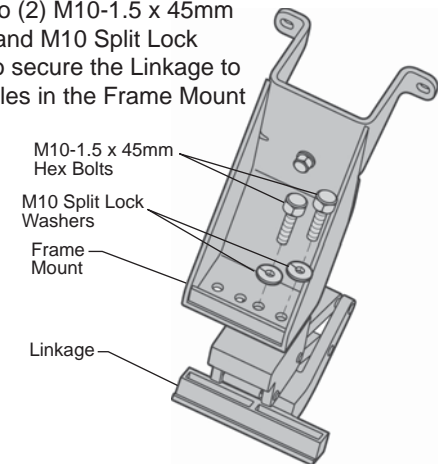

TrekStep Side-Mount™ – Installation Instructions

3 Install Linkage Assembly on Vehicle

Locate the support column on the frame of the vehicle. Slip the Mounting Bracket Insert on the back of the assembly into the slot in the support column. Finger tighten the M10-1.5 x 30mm Hex Bolt.

NOTE On Long bed vehicles with two (2) support columns, either support may be used.

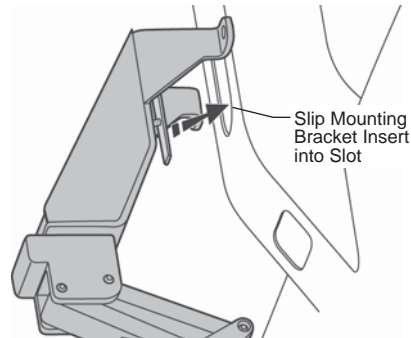
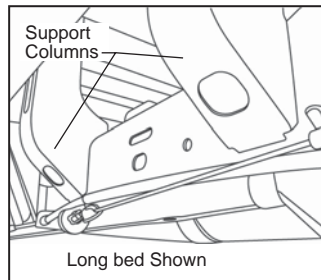

4 Install Rear Bracket

Use two (2) M10 Flat Washers and M10 Nylock Nuts to mount the Rear Bracket to the Frame Mount from the back of the support column.

Do not tighten the bracket completely.

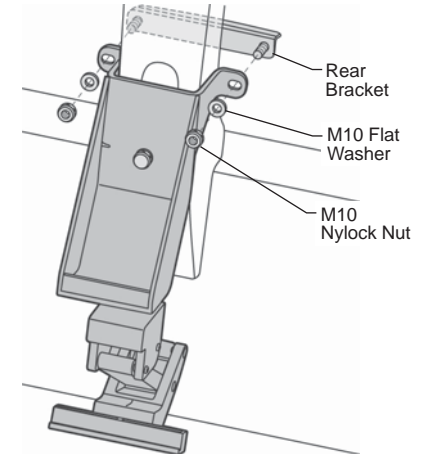

5 Install Step

Use the M6-1.0 x 20 Socket Head Cap Screws to mount the Step to the Linkage Assembly.

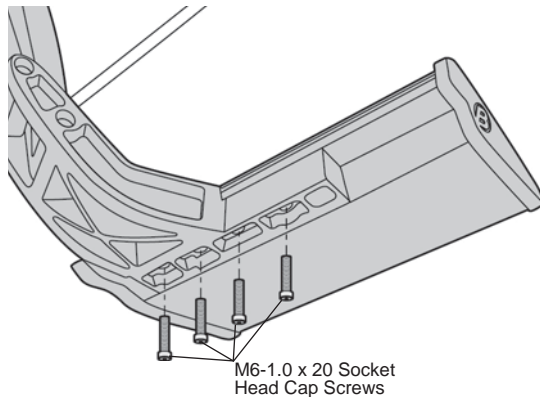

6 Step Adjustment

Once the Step is installed on the vehicle, you may adjust it as desired.

If necessary to adjust the height, use the 1/4" Spacer provided. Remove the M10-15 x 45mm Hex Bolts installed in Step 2 and place the 1/4" Spacer between the Frame Mount and the Linkage. Reinstall the Hex Bolts.

When the Step is in the desired position tighten all fasteners.

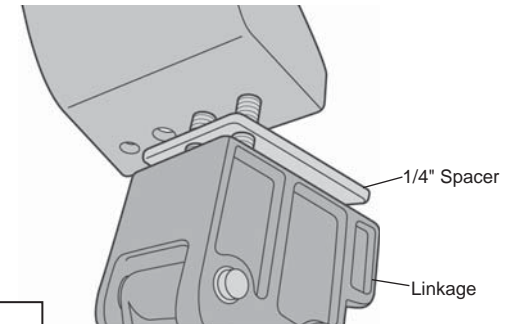
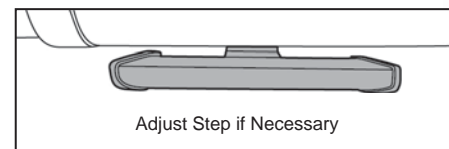

TrekStep Side-Mount™ – Installation Instructions

Operation

- The TrekStep™ is foot operated and deploys and retracts with a nudge of your foot.
- To deploy, press down using your foot, on the forward outside corner of the step pad.
- To retract, gently kick the underside of the step pad.
- Max Load Capacity: 400 lbs.
- Always use appropriate hand holds when stepping up to or down from your truck's cargo bed.

Care and Maintenance

The step pad surface and linkage arms should be washed with mild soap and water using a soft brush or sponge to dislodge any mud, dirt or accumulated road grime. Rinse with fresh water. After it is dry, lubricate the hinge with 3-IN-ONE Oil.

To prevent slipping, avoid applying waxes, lubricants or protectants like Armor All® to the step surface.

Attention!

TrekStep™ SHOULD ALWAYS BE STOWED IN THE RETRACTED POSITION WHEN DRIVING.

LIMITED WARRANTY

We warrant our product to be free from defects in material and workmanship, for the terms specified below, provided there has been normal use and proper maintenance. This warranty applies to the original purchaser only. All remedies under this warranty are limited to the repair or replacement of any item or items found by the factory to be defective within the time period specified. If you have a warranty claim, first you must call our factory at the number below for instructions. You must retain proof of purchase and submit a copy with any items returned for warranty work. Upon completion of warranty work, if any, we will return the repaired or replaced item or items to you freight prepaid. Damage to our products caused by accidents, fire, vandalism, negligence, misinstallation, misuse, Acts of God, or by defective parts not manufactured by us, is not covered under this warranty.

THE WARRANTY TIME PERIOD IS AS FOLLOWS FOR ALL TrekSteps™ MANUFACTURED BY OUR COMPANY: THREE YEARS / 36,000 MILES FROM DATE OF PURCHASE.

ANY IMPLIED WARRANTIES OF MERCHANTABILITY AND/OR FITNESS FOR A PARTICULAR PURPOSE CREATED HEREBY ARE LIMITED IN DURATION TO THE SAME DURATION AND SCOPE AS THE EXPRESS WRITTEN WARRANTY. OUR COMPANY SHALL NOT BE LIABLE FOR ANY INCIDENTAL OR CONSEQUENTIAL DAMAGE.

Some states do not allow limitations on how long an implied warranty lasts, or the exclusion or limitation of incidental or consequential damages, so the above limitations or exclusions may not apply to you. This warranty gives you specific legal rights, and you may also have other rights which vary from state to state.



For further information or request for warranty work, please contact:
Bestop Inc. Customer Service
Toll-Free: (800)845-3567
Main: (303)465-1755
E-mail: csbestop@Bestop.com
Website: www.Bestop.com