



Installation Instructions

PowerBoard® NX

Automatic Retracting Running Board

Vehicle Application

- Ford Super Duty F-250/350/450 Crew Cab
2008 – Current
Part Number: 75634-15

Patent Pending

www.bestop.com - We're here to help! Visit our web site and click on "Ask a Question". Click here for more [Truck Accessories by Bestop](#).

INSTALLATION TIME  3 Hours		SKILL LEVEL  3 - Moderately Difficult		
TOOLS				
 Tape Measure	 Flat-Head Screwdriver	 Phillips Screwdriver	 Ratchet	 Extension
 Socket 8 mm, 13 mm	 Wrench 13 mm	 Crimp Tool	 Allen Wrench 7/32" and 5 mm	 Vise Grips
 Torque Wrench	 Safety Glasses			



! WARNING The manufacturer strongly recommends that this product be professionally installed.

! WARNING Failure to carefully follow the electrical installation steps could result in severe electrical shock which could harm the installer and/or damage the vehicle.

! WARNING Do not rely in any way on the components of this product to protect against injury or death in the event of an accident. Never operate the vehicle in excess of manufacturer's specifications.

WEAR SEAT BELTS AT ALL TIMES

Read and follow, precisely, all installation instructions provided when installing product. Failure to do so may result in a poor fit and could place occupants of the vehicle in a potentially dangerous situation.

PowerBoard® NX – Installation Instructions

Parts List and Hardware Identification

Idler Linkage, Part Number 473.07, Qty - 2
 Motor Linkage, Part Number 473.08, Qty - 2
 Motor (for use with Blue Controller), Part Number 496.12, Qty - 2
 Running Board Assembly, Qty - 2
 79" - Part Number 514.07
 Blue Controller, Part Number 496.11, Qty - 1
 Light, Part Number 470.15, Qty - 4
 7" Cable Ties, Part Number 460.99, Qty - 25
 11" Cable Ties, Part Number 470.02, Qty - 2
 Brake Cable Bracket, Part Number 473.13, Qty - 1
 M6-1.0 x 35 Socket Cap Screw, Part Number 460.95, Qty - 6
 M8-1.25 x 25 Hex Bolt, Part Number 474.86, Qty - 1
 M10-1.75 x 25 Socket Cap Screw, Part Number 473.19, Qty - 8
 M8-1.25 x 30 Hex Bolt, Part Number 473.18, Qty - 8
 M6-1.0 x 20 Socket Cap Screw, Part Number 470.00, Qty - 8
 Nylock Nut, Part Number 470.06, Qty - 1
 8mm Fender Washer, Part Number 473.21, Qty - 1
 M8 Washer, Part Number 470.05, Qty - 8
 M6 Flat Washer, Part Number 481.96, Qty - 6
 10mm Washer, Part Number 473.20, Qty - 8
 M8 U-Nut, Part Number 460.98, Qty - 8
 Wiring Harness, Part Number 495.54, Qty - 1
Wireless Component Kit
 Sensor - Driver Side Front, Part Number 492.01, Qty - 1
 Sensor - Passenger Side Front, Part Number 492.00, Qty - 1
 Sensor - Driver Side Rear, Part Number 492.03, Qty - 1
 Sensor - Passenger Side Rear, Part Number 492.02, Qty - 1
 Receiver, Part Number 491.99, Qty - 1
 Magnet, Part Number 491.97, Qty - 5
 17" Nylon Zip Tie, Part Number 492.06, Qty - 2
 Magnet Holder, Part Number 491.98, Qty - 5

PowerBoard® NX – Installation Instructions

RF System Overview

The PowerBoards® are activated by Sensors that are to be mounted inside the door openings for each door. The Sensors are off when a magnet is next to the Sensor end that has the two screws. The Sensor triggers the PowerBoards® to deploy when the magnet is moved about 3 inches away from the Sensor. The magnet can work in either of the locations shown to signal the PowerBoards® to retract.

Be sure to mount the Sensors in a location that will allow removal of the screws for battery replacement. See Battery Replacement at the end of the instructions.

See Steps 14 – 20 for detailed instructions.

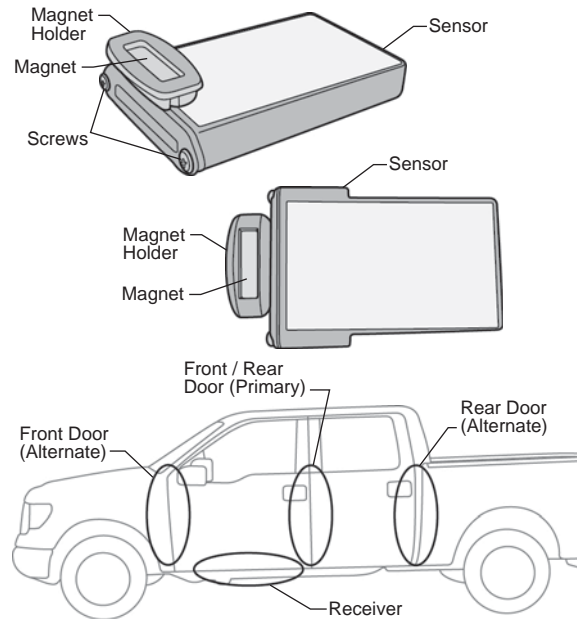

1 System Initialization

- Remove fuse from the PowerBoard® wire harness and connect the red lead to the battery positive and the black lead to negative.
- Layout the harness so the long leg crosses the engine compartment towards the drivers side and the short leg is on the passenger side.
- Attach a motor to each motor link with 3 M6-1.0 x 35mm Socket Cap Screws.
- Plug the Controller, Receiver, Motors and Lights into the harness.
- Plug the fuse back into the harness. After a one second delay the linkages will retract as shown.
- Lay out all four sensors as they would be installed on the vehicle with the drivers side to your left and the passengers side to your right. Place a magnet next to each sensor as shown in the overview above.
- Move the magnet more than 4 inches away from the driver front sensor. All four lights will come on and the drivers side linkage will deploy.
- Move the magnet back to the sensor and after a three second delay the lights will turn off and the linkage will retract.
- Repeat with the remaining sensors and the lights and corresponding linkage will operate in the same manner.
- Remove the motors to continue with the installation.

If the system does not operate as stated above see the Troubleshooting and Battery Replacement sections at the end of the instructions or go to our web site at <http://www.bestop.com/support>.

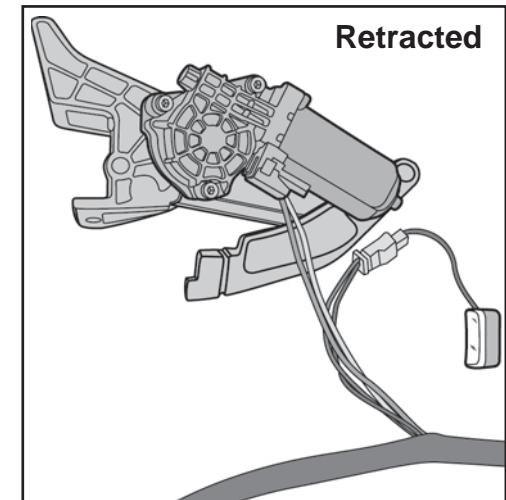
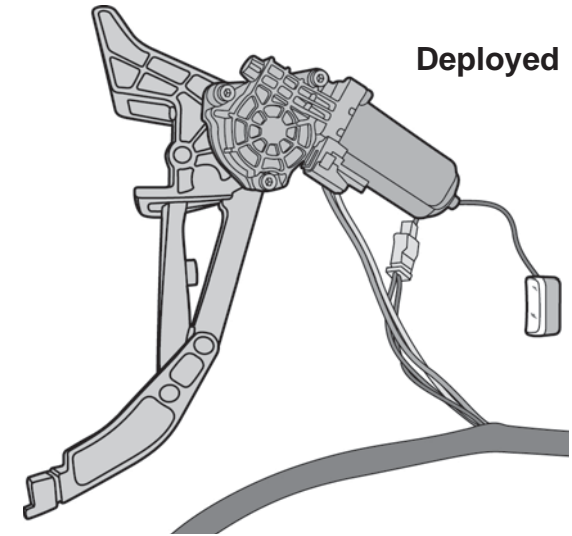

PowerBoard® NX – Installation Instructions

2 Install M8 U-Nuts

Counting from the front, locate the second (2nd) and last set of mounting holes on the inner sill on the driver's side. Use an M8-1.25 x 30 Hex Bolt and an 8mm Washer to install an M8 U-Nut on each side of each hole. Do not tighten the bolts at this time.

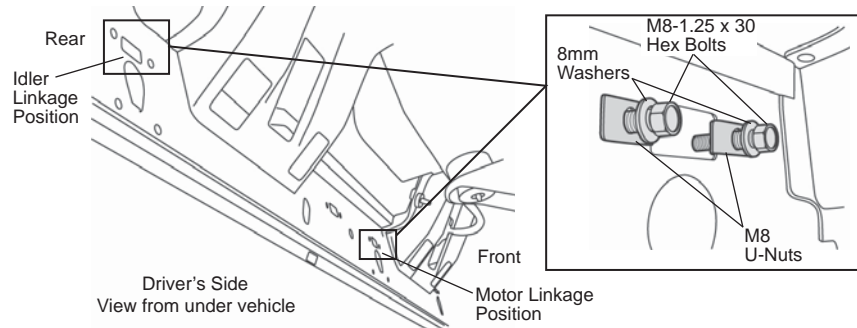

3 Install Linkages

Install an Idler Linkage in the rear hole and a Motor Linkage in the front hole. Slip the notches in the Linkages under the bolts and washers installed in Step One. Secure the bottom of the Linkages with two M10-1.75 x 25 Button Head Screws and two 10mm Washers.

Do not tighten the bolts at this time.

Repeat Steps One and Two on the passenger side of the vehicle.

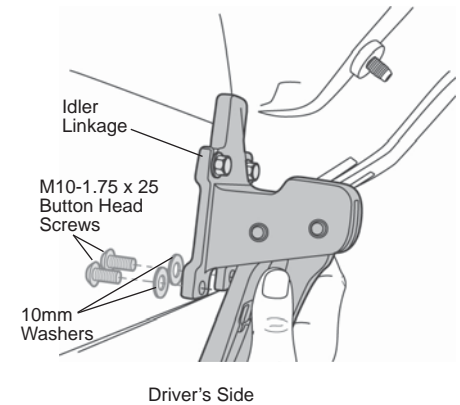

4 Loosen Parking Brake Cable

Disengage parking brake. Pull parking brake cable to the rear from the forward support bracket to create slack in the cable. Secure the cable slack with vise-grips.

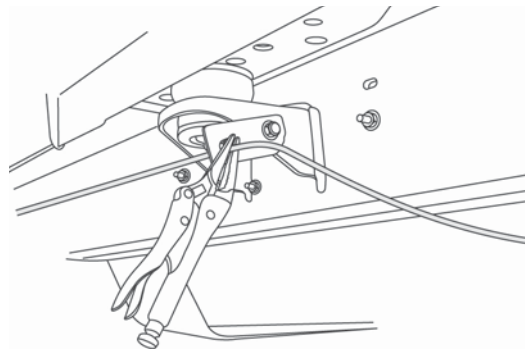

5 Install Brake Cable Bracket

Remove the cable from the rear support bracket and use the Hex Bolt, 8mm Washer and Nylock Nut to install the Brake Cable Bracket on the front of the support bracket. Reinstall the parking brake cable and remove vise-grips.

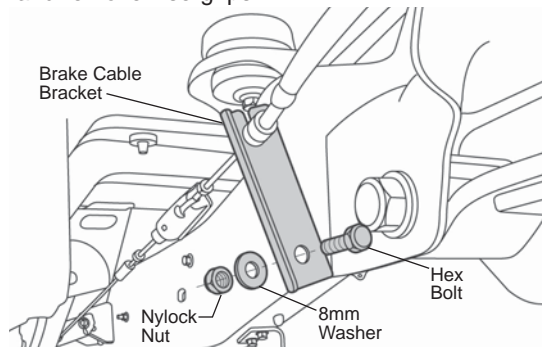

WARNING Remove the fuse from the Wiring Harness.

6 Remove Fuse from Wiring Harness

Remove the fuse from the Wiring Harness. Failure to do so could result in severe electrical shock which could harm the installer and/or damage the vehicle.

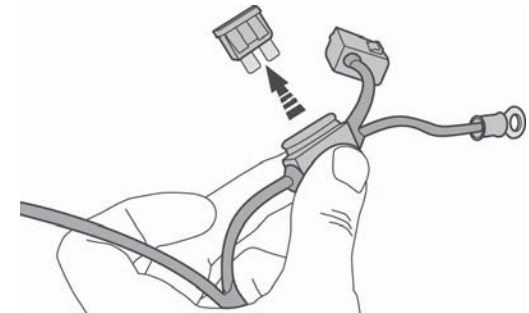

PowerBoard® NX – Installation Instructions

7 Connect Controller to Wire Loom and Wire Harness

Connect the Controller to the vehicle wire loom. Connect both connectors on the Wire Harness in the parts kit to the connectors on the Controller. Secure the locking tabs on the connectors.

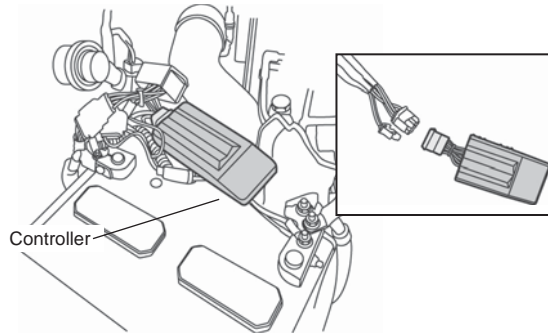

CAUTION

Do Not install on or near hot surfaces.

8 Secure Controller and Wire Harness

Connect the Controller power and ground to battery, red lead to positive and black lead to negative. (Skip if still attached from Step 1.)

Route the Wire Harness legs down to the wheels wells and to the Motor Linkages. The long leg goes across the front to the driver's side.

Use Cable Ties to secure all loose sections of the harness.

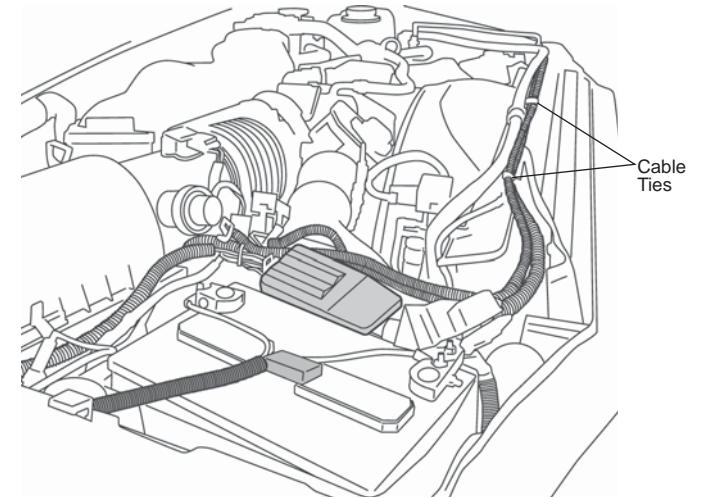

9 Route Wire Harness

Run the legs of the Wire Harness down and along under the vehicle. Use Cable Ties to secure it.

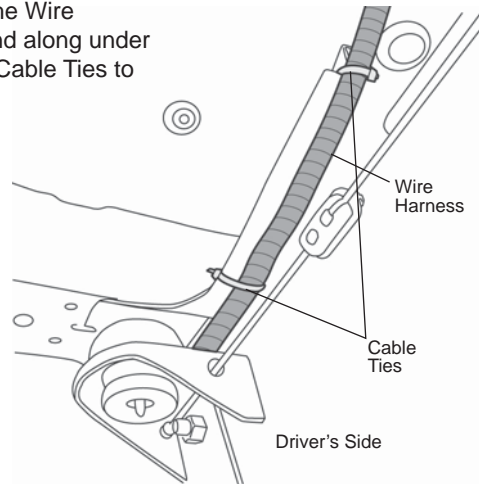

10 Install Receiver

Route the small diameter wire harness along the side of the frame. Find a location that is protected but is not surrounded by dense metal. Plug in the Receiver and insert 17" Nylon Zip Ties through the loops on the Receiver. Mount the Receiver with the stand off ribs against the vehicle.

NOTE

Due to vehicle variations, installation may differ from that shown.

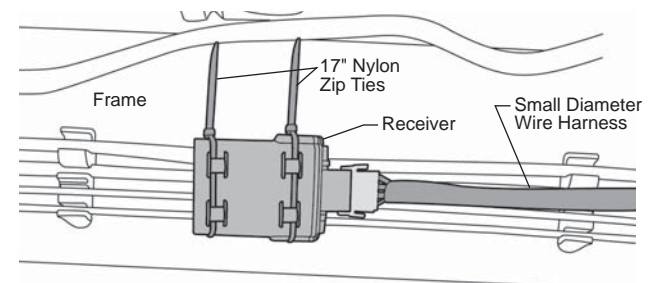

PowerBoard® NX – Installation Instructions

11 Install Running Boards

Mount the Steps to the linkages. Slide the mounting T-Nut into position. Install M6-1.0 x 20mm Socket Head Bolts to secure the boards. Use a 5mm Allen Wrench to tighten the bolts.

Make sure the board moves up and down freely by hand. If it binds, loosen the linkage to body attachment bolts and adjust the linkage position until the boards move freely. **Do not tighten the bolts at this time.**

NOTE *Tightening the fasteners before cycling the step several times may create a bind, causing a squeaking sound and preventing the boards from retracting completely and evenly.*

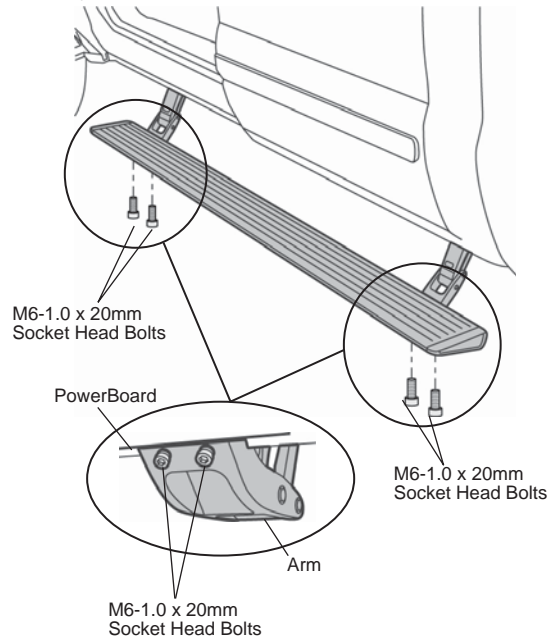

12 Install Motor

Slide Motor assembly onto drive shaft and mounting bosses of Motor Linkage assembly. Use three (3) M6-1.0 x 35mm Socket Cap Screws and M6 Flat Washers to secure Motor. Plug female connector into Motor.

Torque
5-7 ft. lbs.
(6.78-9.49 Nm / 60-84 in. lbs.)
Do not exceed 7 ft. lbs. of torque

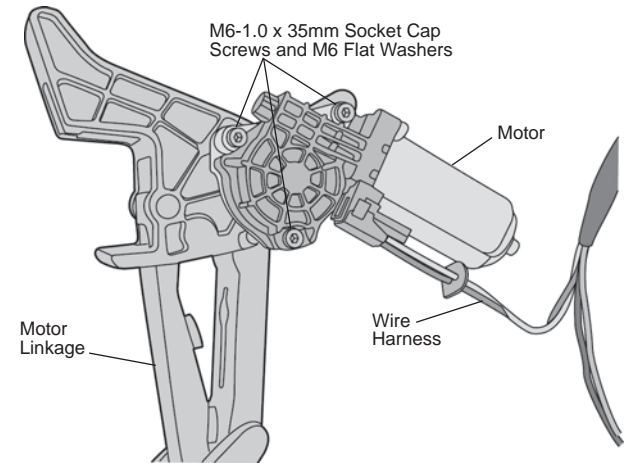

13 Install Magnet

Open the back door on the driver's side and clean the area where the magnet and sensor will be installed with a 50/50 solution of water and alcohol. Stick a magnet to the back side of the front door as shown. Hold the Drivers Front Sensor against the door pillar and position the magnet so it is directly in front of the sensor.

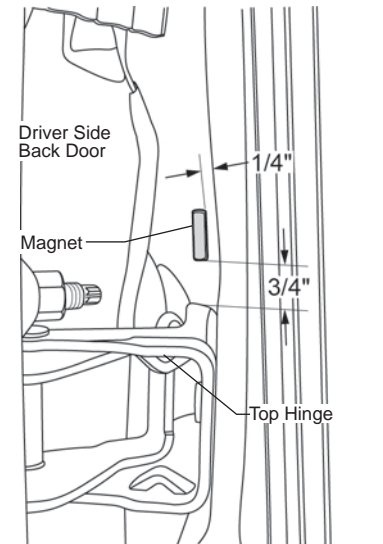

PowerBoard® NX – Installation Instructions

14 Install Driver's Side Front Sensor

Peel the liner off of the Drivers Side Front Sensor. Position it on the door pillar so it is about 1/6" away from the magnet. Press firmly on the Sensor to stick it to the pillar.

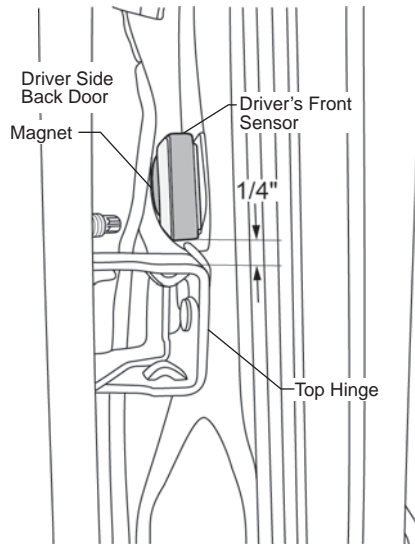

15 Install Magnet

Open the front driver's side door and clean the area where the magnet and sensor will be installed with a 50/50 solution of water and alcohol. Stick a magnet to the front side of the rear door as shown. Hold the Drivers Rear Sensor against the door pillar and position the magnet so it is directly in front of the sensor.

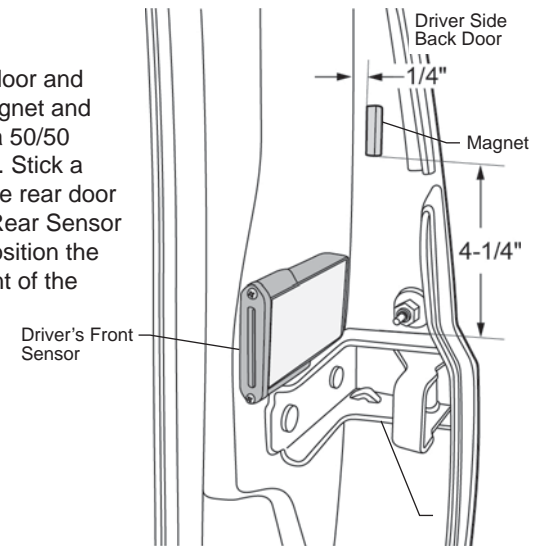

16 Install Driver's Side Rear Sensor

Peel the liner off of the Drivers Side Rear Sensor. Position it on the door pillar so it is about 1/6" away from the magnet. Press firmly on the Sensor to stick it to the pillar.

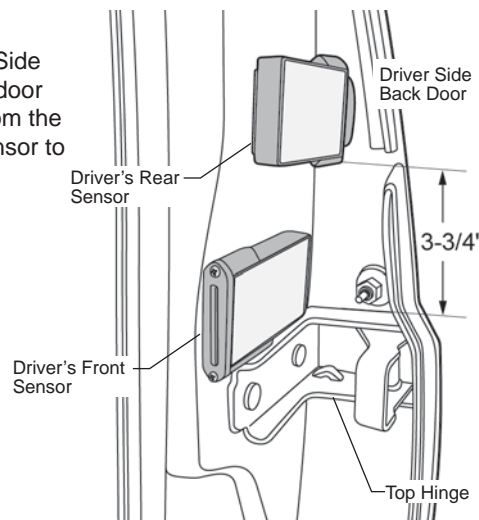

17 Install Passenger Side Sensors and Magnets

Repeat Steps 14 through 16 on the passenger side of the vehicle.

18 Reinstall Fuse

Reinstall fuse in PowerBoard® wire harness.

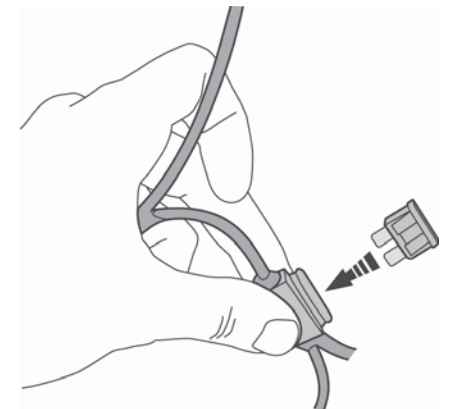

PowerBoard® NX – Installation Instructions

19 Test Doors and PowerBoards®

Open and shut each door to make sure the PowerBoards® deploy and retract. There is a slight delay in the board deployment so make sure they are fully down before stepping on them. There is also a 3-4 second delay in board retraction after the door is shut. This gives you time to open another door with out cycling the board again. **Cycle the boards several times and then fully tighten all of the fasteners.**



CAUTION

Never force the board up or down. Use the motors to cycle the board.

Order to tighten screws:
Board to Linkage 1st
Linkage to Body 2nd

Torque
5-7 ft. lbs.
(6.78-9.49 Nm / 60-84 in. lbs.)
Do not exceed 7 ft. lbs. of torque

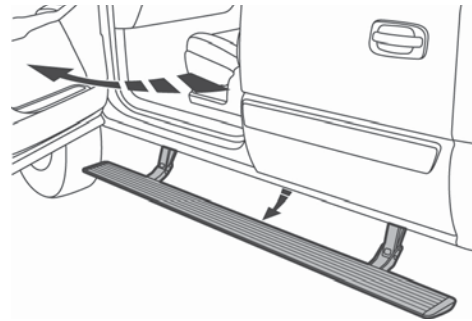

20 Install Lights

Clean the outboard surface of the of the Linkage below the bottom mounting bolt. Peel the adhesive liner off the back of the Light and firmly press it 1/8" below the mounting bolt. Plug the light into the connector with the black and orange wires in the wire harness. Repeat with the other three lights. Secure loose wires with Cable Ties.

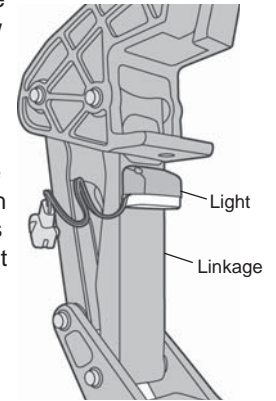

21 Install Magnet Holders

Peel the liner off the back of a magnet holder and place it around the magnet. Be careful not to move the magnet. Press firmly on the holder to stick it to the door.

Repeat for all Magnets.

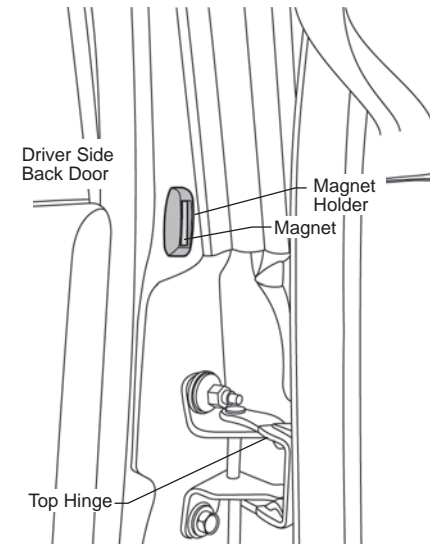
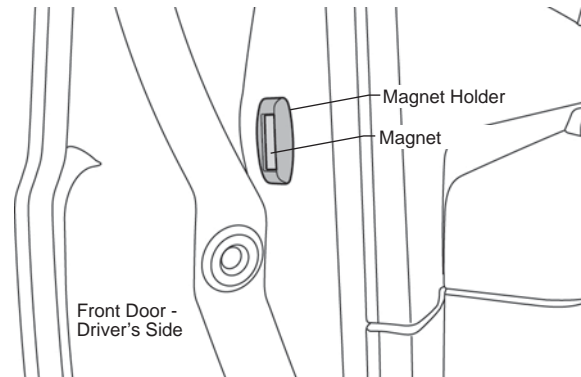

PowerBoard® NX – Installation Instructions

PowerBoard® NX Troubleshooting

Issue:

- Possible cause

Boards do not operate:

- Bad ground
- Bad battery connection
- Fuse burned
- Magnet is too far away from Sensor
- Bad receiver connection
- Sensor battery low

Board creaks or squeaks during operation:

- Gear shaft wedge bolt is loose
- Loosen mounting bracket and board attachment screws. Adjust linkages so they are parallel to each other and the noise is gone. Tighten all fasteners.

Intermittent operation:

- Bad battery connection
- Bad ground
- Magnet is too far away from Sensor
- Bad receiver connection
- Sensor battery low

Boards operate randomly:

- Wire connections not secure
- Magnet is too far away from Sensor
- Bad receiver connection
- Sensor battery low

Board stays down all the time and can be moved by hand:

- Gear shaft wedge screw is missing or loose

Board shakes and or shutters during operation:

- Bad ground
- Wire connections not secure
- Bad battery connection
- Links misaligned

Delay in board operation or boards operate after doors are shut:

- Magnet is too far away from Sensor
- Sensor battery low

Board hits body

- Install supplied adhesive bumper per the installation instructions.

Board does not fully retract or deploy

- The board is designed to stop travel when the system senses a load. Misalignment can cause the board to stop early. Remove the motor and adjust the linkage alignment until the board moves up and down freely without resistance by hand.

Board retracts when doors are left open for a long period of time.

- This is normal to save sensor battery life.

PowerBoard® NX Service Tips

Adjusting Linkage alignment:

The board is designed to stop travel when the system senses a load. Misalignment can cause the board to stop early.

To adjust, remove running board and motor. Loosen mounting brackets. Adjust linkages parallel to each other. Shift the running board on linkages 1/8" in either direction and carefully set board on linkages. Start only a few threads of the allen head bolts – do not tighten yet. Lift running board to retracted position. Tighten allen head bolts that attach running board to linkage. Last, tighten linkages to body. Cycle running board by hand without motor and confirm zero resistance. Install motor and test.

Linkage Component Identification

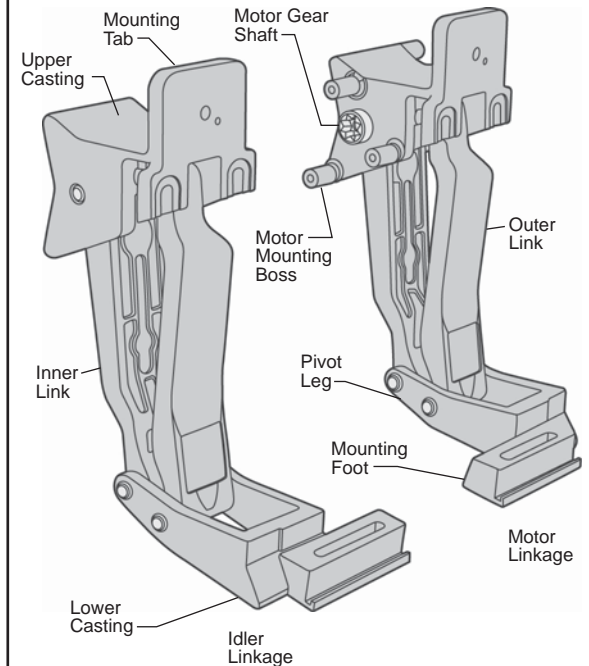

PowerBoard® NX – Installation Instructions

Battery Replacement

Each sensor is powered by a CR2450 3 volt battery that may periodically need to be replaced.

1. Remove the PowerBoard® wire harness fuse that is next to the car battery.
2. Remove the two screws and the cover plate on the sensor. Slide out the circuit board and note the orientation of the board. Replace the battery and slide the board back into the housing with its original orientation. Leave the vehicle door or doors open.
3. Reinstall the PowerBoard® fuse and wait 30 seconds. The sensor is reprogramming its address during this time.
4. Shut the door(s). Open and close the doors(s) to check for normal operation.

If opening a door fails to operate the PowerBoard, open the appropriate door and remove the PowerBoard® fuse. Wait 30 seconds and the reprogramming will repeat. Reinstall the fuse and check for normal operation.

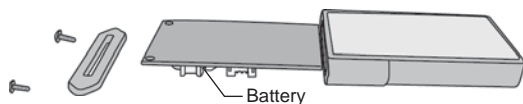

This device complies with Industry Canada licence-exempt RSS standard(s). Operation is subject to the following two conditions: (1) this device may not cause interference, and (2) this device must accept any interference, including interference that may cause undesired operation of the device.

Le présent appareil est conforme aux CNR d'Industrie Canada applicables aux appareils radio exempts de licence. L'exploitation est autorisée aux deux conditions suivantes: (1) l'appareil ne doit pas produire de brouillage, et (2) l'utilisateur de l'appareil doit accepter tout brouillage radioélectrique subi, même si le brouillage est susceptible d'en compromettre le fonctionnement.

This device complies with Part 15 of the FCC Rules. Operation is subject to the following two conditions:

- (1) This device may not cause harmful interference
- and
- (2) This device must accept any interference received, including interference that may cause undesired operation.

The user is cautioned that changes or modifications not expressly approved by the party responsible for compliance could void the user's authority to operate this equipment.

PowerBoard® NX – Installation Instructions

Care and Maintenance

The step pad surface and linkage arms should be washed with mild soap and water using a soft brush or sponge to dislodge any mud, dirt or accumulated road grime. Rinse with fresh water and avoid spraying the motors directly. After it is dry, lubricate the hinge with 3-IN-ONE Oil.

To prevent slipping, avoid applying waxes, lubricants or protectants like Armor All® to the step surface.

Attention!

TrekStep™ SHOULD ALWAYS BE STOWED IN THE RETRACTED POSITION WHEN DRIVING.

LIMITED WARRANTY

We warrant our product to be free from defects in material and workmanship, for the terms specified below, provided there has been normal use and proper maintenance. This warranty applies to the original purchaser only. All remedies under this warranty are limited to the repair or replacement of any item or items found by the factory to be defective within the time period specified. If you have a warranty claim, first you must call our factory at the number below for instructions. You must retain proof of purchase and submit a copy with any items returned for warranty work. Upon completion of warranty work, if any, we will return the repaired or replaced item or items to you freight prepaid. Damage to our products caused by accidents, fire, vandalism, negligence, misinstallation, misuse, Acts of God, or by defective parts not manufactured by us, is not covered under this warranty.

THE WARRANTY TIME PERIOD IS AS FOLLOWS FOR ALL PowerBoards® MANUFACTURED BY OUR COMPANY: THREE YEARS / 36,000 MILES FROM DATE OF PURCHASE.

ANY IMPLIED WARRANTIES OF MERCHANTABILITY AND/OR FITNESS FOR A PARTICULAR PURPOSE CREATED HEREBY ARE LIMITED IN DURATION TO THE SAME DURATION AND SCOPE AS THE EXPRESS WRITTEN WARRANTY. OUR COMPANY SHALL NOT BE LIABLE FOR ANY INCIDENTAL OR CONSEQUENTIAL DAMAGE.

Some states do not allow limitations on how long an implied warranty lasts, or the exclusion or limitation of incidental or consequential damages, so the above limitations or exclusions may not apply to you. This warranty gives you specific legal rights, and you may also have other rights which vary from state to state.



For further information or request for warranty work, please contact:
Bestop Inc. Customer Service
Toll-Free: (800)845-3567
Main: (303)465-1755
E-mail: csbestop@Bestop.com
Website: www.Bestop.com
