



Installation Instructions PowerBoard® NX

Automatic Retracting Running Board



Patent Pending







Vehicle Application

• Toyota Tundra Double Cab
2007 and newer
Part Number: 75636-15

• Toyota Tundra CrewMax
2007 and newer
Part Number: 75637-15

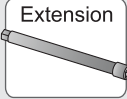
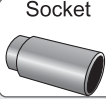
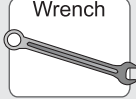
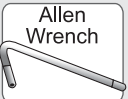
www.bestop.com - We're here to help! Visit our web site and click on "Ask a Question". Click here for more [Truck Accessories by Bestop](#).

INSTALLATION TIME	SKILL LEVEL
 3 Hours	 3 - Moderately Difficult

TOOLS				
 Tape Measure	 Ratchet	 Extension	 Socket	 Wrench
			8mm, 10mm, 12mm, 13mm	13mm
 Allen Wrench	 Electrical Tape	 Torque Wrench	 Safety Glasses	
4 mm, 5 mm, 3/16"				



! WARNING The manufacturer strongly recommends that this product be professionally installed.

! WARNING Failure to carefully follow the electrical installation steps could result in severe electrical shock which could harm the installer and/or damage the vehicle.

! WARNING Do not rely in any way on the components of this product to protect against injury or death in the event of an accident. Never operate the vehicle in excess of manufacturer's specifications.

WEAR SEAT BELTS AT ALL TIMES

Read and follow, precisely, all installation instructions provided when installing product. Failure to do so may result in a poor fit and could place occupants of the vehicle in a potentially dangerous situation.

PowerBoard® NX – Installation Instructions

Parts List and Hardware Identification

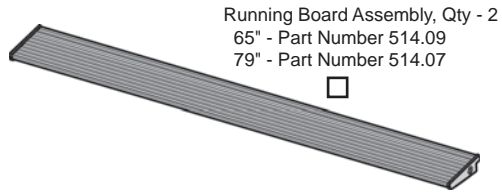

Running Board Assembly, Qty - 2
65" - Part Number 514.09
79" - Part Number 514.07

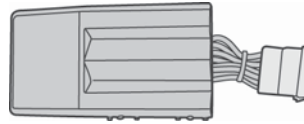

Blue Controller, Part Number 496.11, Qty - 1

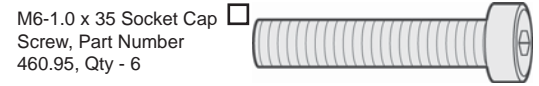

M6-1.0 x 35 Socket Cap Screw, Part Number 460.95, Qty - 6

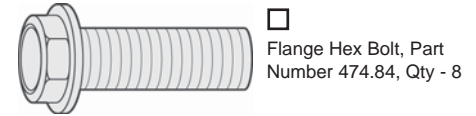

Flange Hex Bolt, Part Number 474.84, Qty - 8

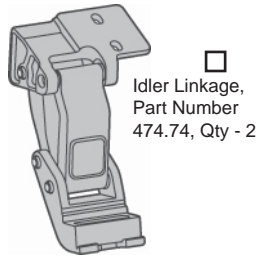

Idler Linkage, Part Number 474.74, Qty - 2

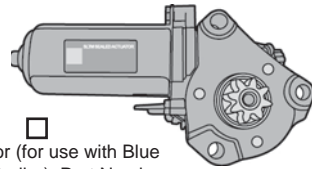

Motor (for use with Blue Controller), Part Number 496.12, Qty - 2

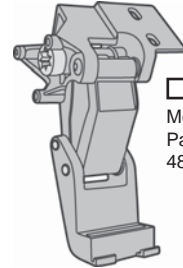

Motor Linkage, Part Number 482.40, Qty - 2

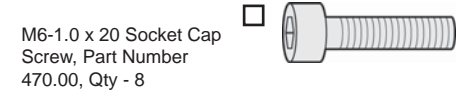

M6-1.0 x 20 Socket Cap Screw, Part Number 470.00, Qty - 8



7" Cable Ties, Part Number 460.99, Qty - 25

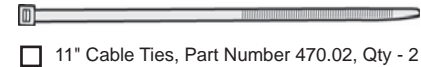

11" Cable Ties, Part Number 470.02, Qty - 2

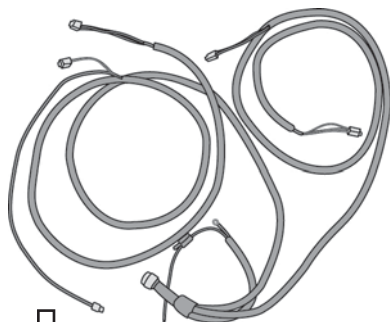

Wiring Harness, Part Number 495.55, Qty - 1

Wireless Component Kit

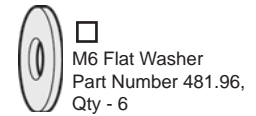
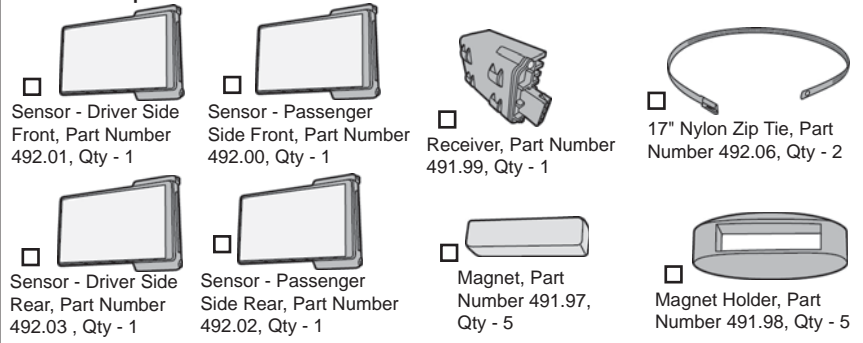

M6 Flat Washer, Part Number 481.96, Qty - 6

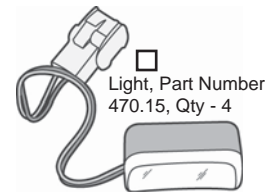

Light, Part Number 470.15, Qty - 4

PowerBoard® NX – Installation Instructions

RF System Overview

The PowerBoards® are activated by Sensors that are to be mounted inside the door openings for each door. The Sensors are off when a magnet is next to the Sensor end that has the two screws. The Sensor triggers the PowerBoards® to deploy when the magnet is moved about 3 inches away from the Sensor. The magnet can work in either of the locations shown to signal the PowerBoards® to retract.

Be sure to mount the Sensors in a location that will allow removal of the screws for battery replacement. See Battery Replacement at the end of the instructions.

See Steps 14 – 20 for detailed instructions.

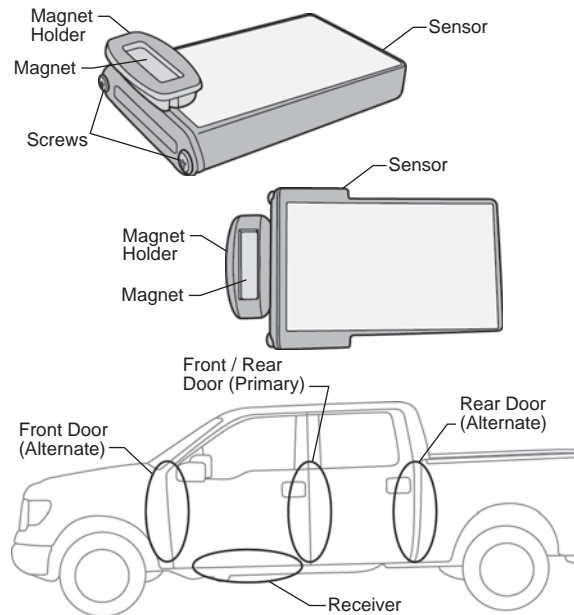

1 System Initialization

- Remove fuse from the PowerBoard® wire harness and connect the red lead to the battery positive and the black lead to negative.
- Layout the harness so the long leg crosses the engine compartment towards the drivers side and the short leg is on the passenger side.
- Attach a motor to each motor link with 3 M6-1.0 x 35mm Socket Cap Screws.
- Plug the Controller, Receiver, Motors and Lights into the harness.
- Plug the fuse back into the harness. After a one second delay the linkages will retract as shown.
- Lay out all four sensors as they would be installed on the vehicle with the drivers side to your left and the passengers side to your right. Place a magnet next to each sensor as shown in the overview above.
- Move the magnet more than 4 inches away from the driver front sensor. All four lights will come on and the drivers side linkage will deploy.
- Move the magnet back to the sensor and after a three second delay the lights will turn off and the linkage will retract.
- Repeat with the remaining sensors and the lights and corresponding linkage will operate in the same manner.
- Remove the motors to continue with the installation.

If the system does not operate as stated above see the Troubleshooting and Battery Replacement sections at the end of the instructions or go to our web site at <http://www.bestop.com/support>.

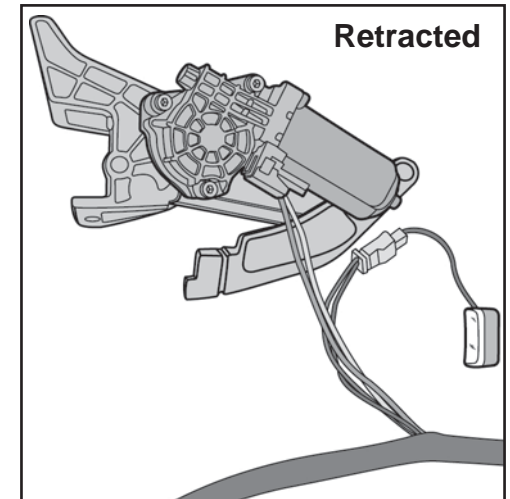
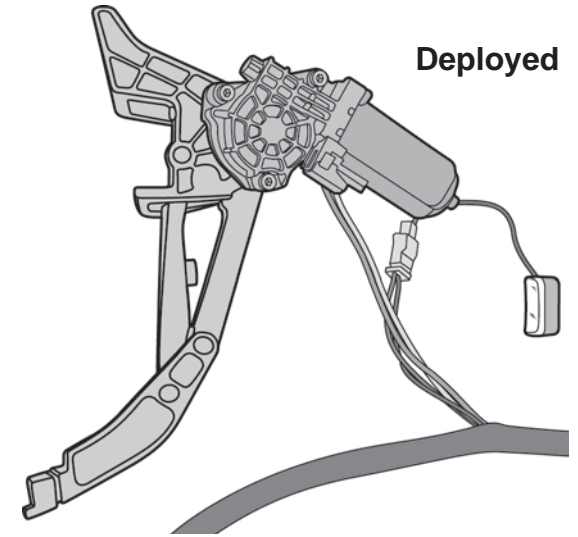

PowerBoard® NX – Installation Instructions

2 Rotate Parking Brake Cable Support – CrewMax Only (Double Cab skip to Step 3)

Remove the parking brake cable support from the frame. Separate the bracket and remove it from the brake cable. Rotate the bracket 180° to cable. Reinstall the support on the frame with the bolt below the cable.

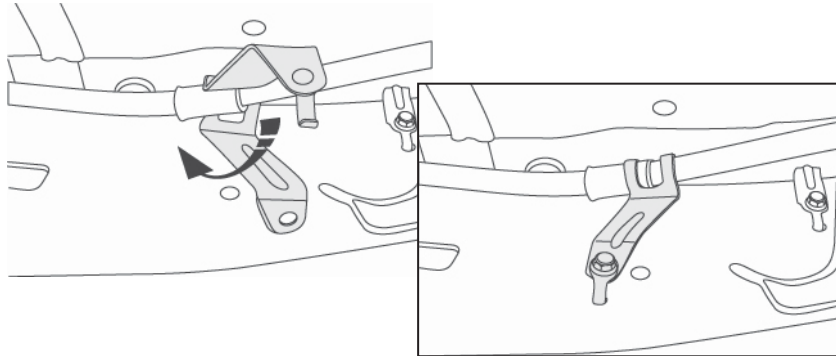

3 Install Motor

Slide Motor assembly onto drive shaft and mounting bosses of Motor Linkage assembly. Use three (3) M6-1.0 x 35mm Socket Cap Screws and (3) M6 Flat Washers to secure Motor. Plug female connector into Motor. Wrap any exposed wires from the motor with electrical tape. Torque the screws to 5–7 ft. lbs. (6.78–9.49 Nm or 60-84 in. lbs.).

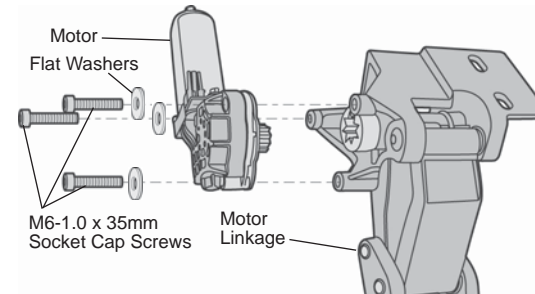

4 Install Front Motor Linkages

Remove the two (2) existing bolts. Install the Motor Linkage in the second set of holes from the front on the driver's side for 75136 and the front set of holes on the 75137. Secure it with two (2) Flange Hex Bolts.

Finger tighten fasteners at this time.

Install passenger side Motor Linkage in the same manner.

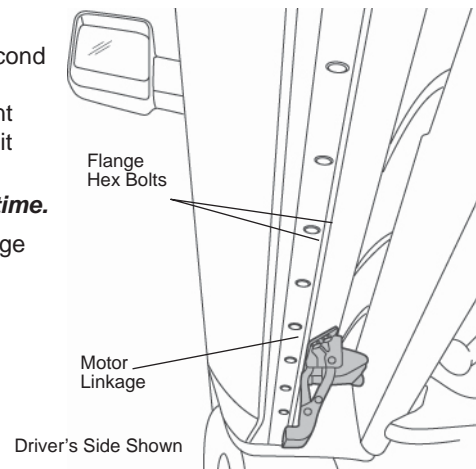

5 Install Rear Linkages

Remove the two (2) existing bolts. Install an Idler Linkage in the rear set of holes on the driver's side. Secure it with two (2) Flange Hex Bolts.

Finger tighten fasteners at this time.

Install passenger side Rear Linkage in the same manner.

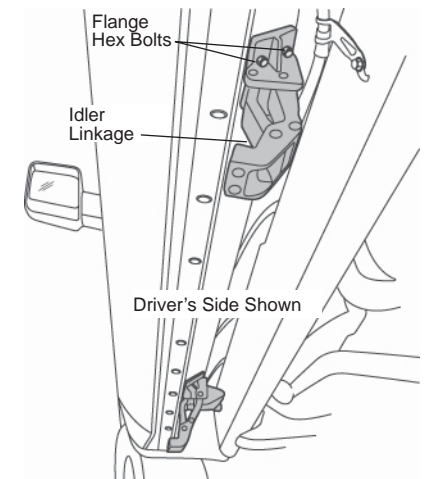

PowerBoard® NX – Installation Instructions

! WARNING Remove the fuse from the Wiring Harness.

6 Remove Fuse from Wiring Harness

Remove the fuse from the Wiring Harness. Failure to do so could result in severe electrical shock which could harm the installer and/or damage the vehicle.

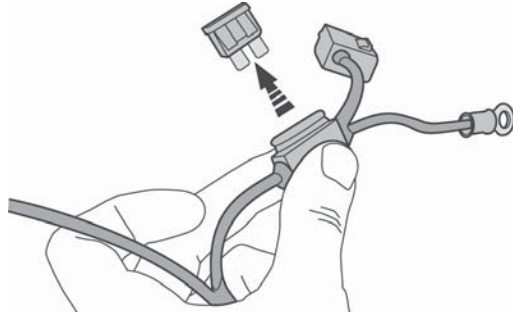

7 Connect Wire Harness to Controller and Battery

Connect the connectors on the Wire Harness in the parts kit to the connectors on the Controller. Secure the locking tabs on the connectors.

Connect the red power lead to the positive battery terminal and the black lead to the grounding lug on the fender apron.

Skip to next step if still attached from Step 1.

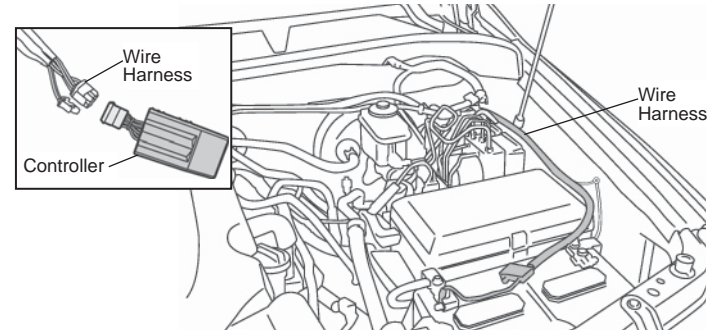

! CAUTION Do Not install on or near hot surfaces.

8 Install Controller

Install the Controller on the driver's side of the engine compartment. Use the 11" Cable Ties to secure it to the factory wiring loom.

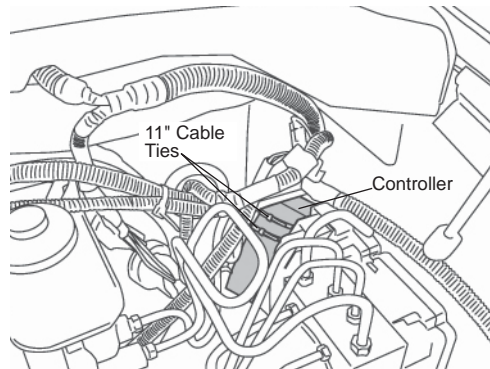

! CAUTION Do Not install on or near hot surfaces.

9 Route Wire Harness

Route the long leg of the Wire Harness across the fire wall to the passenger side and down under vehicle along the outside of the frame rail. Secure with 7" Cable Ties.

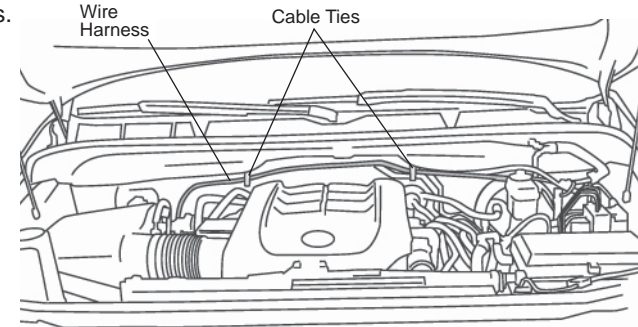

PowerBoard® NX – Installation Instructions

10 Route Wire Harness

Route the shorter leg of the Wire Harness down the driver side fender well and under vehicle along the inside of the frame rail. Secure with 7" Cable Ties.

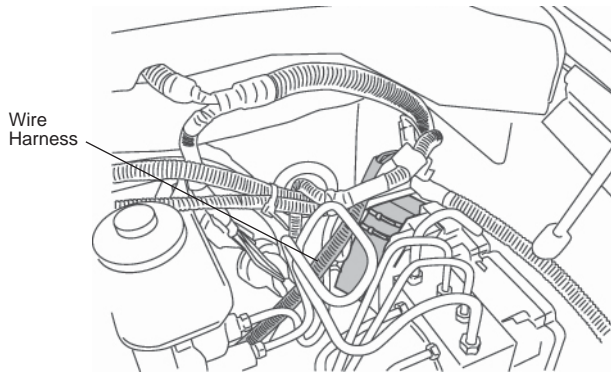

11 Install Receiver

Route the small diameter wire harness along the side of the frame. Find a location that is protected but is not surrounded by dense metal. Plug in the Receiver and insert 17" Nylon Zip Ties through the loops on the Receiver. Mount the Receiver with the stand off ribs against the vehicle.

NOTE Due to vehicle variations, installation may differ from that shown.

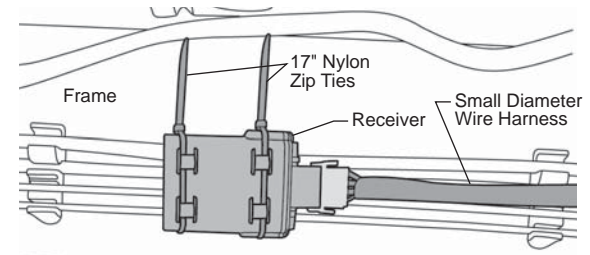

12 Install Running Boards

Mount the Steps to the linkages. Slide the mounting T-Nut into position. Install M6-1.0 x 20mm Socket Head Bolts to secure the boards. Use a 5mm Allen Wrench to tighten the bolts.

Do not fully tighten the bolts at this time.

NOTE *Tightening the fasteners before cycling the step several times may create a bind, causing a squeaking sound and preventing the boards from retracting completely and evenly.*

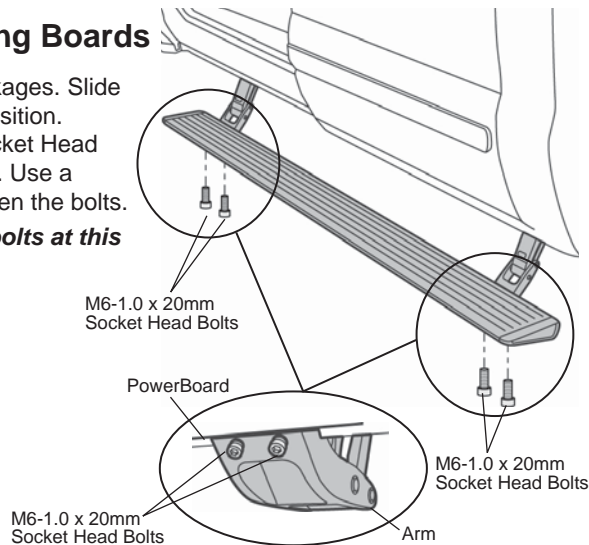

13 Install Motor

Slide Motor assembly onto drive shaft and mounting bosses of Motor Linkage assembly. Use three (3) M6-1.0 x 35mm Socket Cap Screws and M6 Washers to secure Motor. Plug female connector into Motor.

Torque
5-7 ft. lbs.
(6.78-9.49 Nm / 60-84 in. lbs.)
Do not exceed 7 ft. lbs. of torque

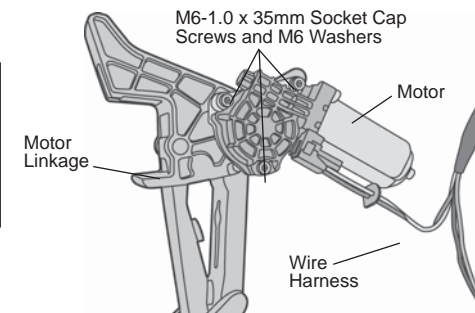

PowerBoard® NX – Installation Instructions

14 Install Magnet

Open the back door on the driver's side and clean the area where the magnet and sensor will be installed with a 50/50 solution of water and alcohol. Stick a magnet to the back side of the front door as shown. Hold the Drivers Front Sensor against the door pillar and position the magnet so it is directly in front of the sensor.

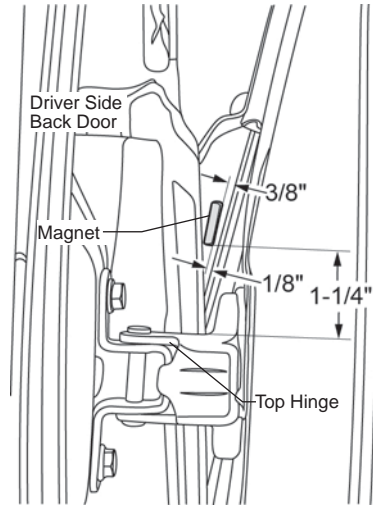

15 Install Driver's Side Front Sensor

Peel the liner off of the Drivers Side Front Sensor. Position it on the door pillar so it is about 1/6" away from the magnet. Press firmly on the Sensor to stick it to the pillar.

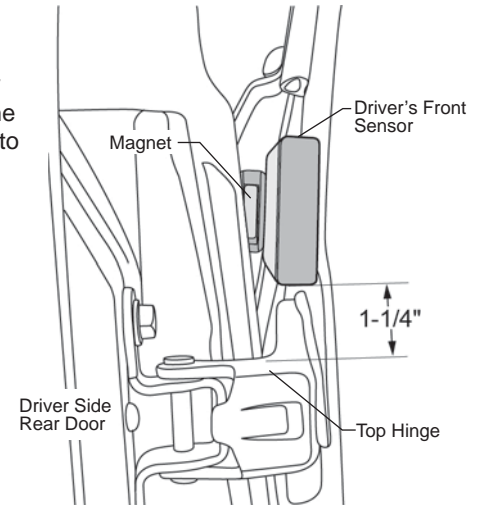

16 Install Magnet

Open the front driver's side door and clean the area where the magnet and sensor will be installed with a 50/50 solution of water and alcohol. Stick a magnet to the front side of the rear door as shown. Hold the Drivers Rear Sensor against the door pillar and position the magnet so it is directly in front of the sensor.

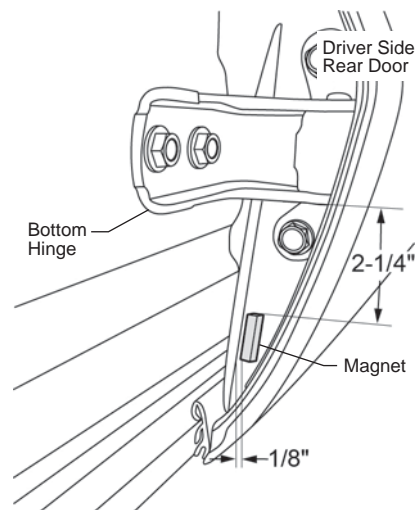

17 Install Driver's Side Rear Sensor

Peel the liner off of the Drivers Side Rear Sensor. Position it on the door pillar so it is about 1/6" away from the magnet. Press firmly on the Sensor to stick it to the pillar.

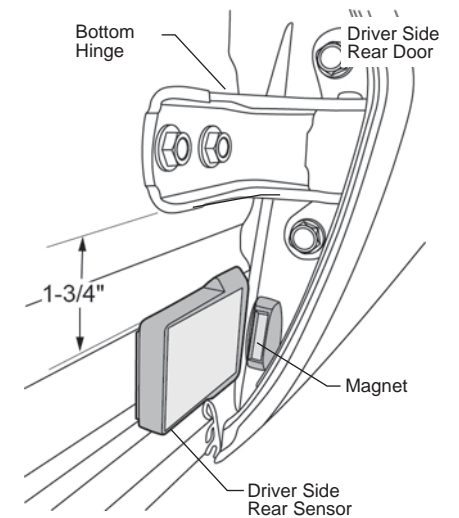

PowerBoard® NX – Installation Instructions

18 Install Passenger Side Sensors and Magnets

Repeat Steps 14 through 17 on the passenger side of the vehicle.

19 Reinstall Fuse

Reinstall fuse in PowerBoard® wire harness.

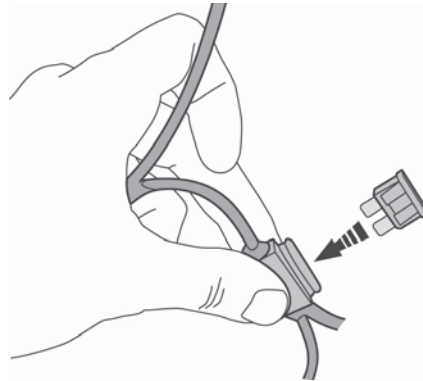

20 Test Doors and PowerBoards®

Open and shut each door to make sure the PowerBoards® deploy and retract. There is a slight delay in the board deployment so make sure they are fully down before stepping on them. There is also a 3-4 second delay in board retraction after the door is shut. This gives you time to open another door with out cycling the board again. **Cycle the boards several times and then fully tighten all of the fasteners.**



Never force the board up or down. Use the motors to cycle the board.

Torque
5-7 ft. lbs.
(6.78-9.49 Nm / 60-84 in. lbs.)
Do not exceed 7 ft. lbs. of torque

Order to tighten screws:
Board to Linkage 1st
Linkage to Body 2nd

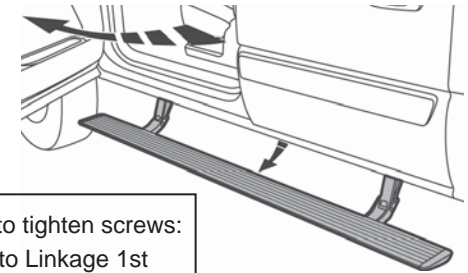

21 Install Flag Connectors

Orient the flag connectors with the yellow wire toward the linkage on both driver's and passenger sides. Attach the flag connectors to the motors.

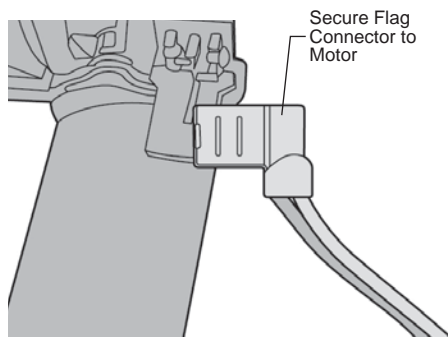

22 Install Lights

Clean the outboard surface of the of the Linkage below the bottom mounting bolt. Peel the adhesive liner off the back of the Light and firmly press it 1/8" below the mounting bolt. Plug the light into the connector with the black and orange wires in the wire harness. Repeat with the other three lights. Secure loose wires with Cable Ties.

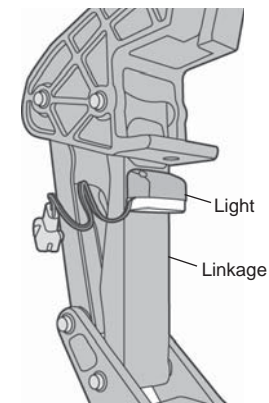

PowerBoard® NX – Installation Instructions

23 Install Magnet Holders

Peel the liner off the back of a magnet holder and place it around the magnet. Be careful not to move the magnet. Press firmly on the holder to stick it to the door.

Repeat for all Magnets.

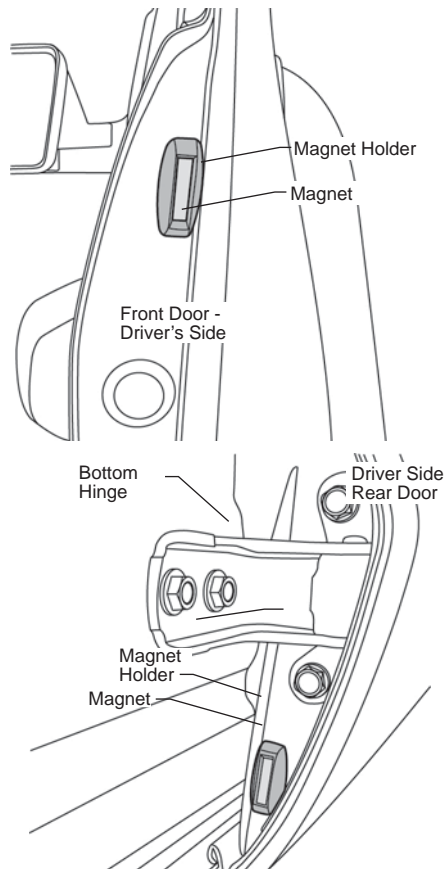

PowerBoard® NX Troubleshooting

Issue:

- Possible cause

Boards do not operate:

- Bad ground
- Bad battery connection
- Fuse burned
- Magnet is too far away from Sensor
- Bad receiver connection
- Sensor battery low

Board creaks or squeaks during operation:

- Gear shaft wedge bolt is loose
- Loosen mounting bracket and board attachment screws. Adjust linkages so they are parallel to each other and the noise is gone. Tighten all fasteners.

Intermittent operation:

- Bad battery connection
- Bad ground
- Magnet is too far away from Sensor
- Bad receiver connection
- Sensor battery low

Boards operate randomly:

- Wire connections not secure
- Magnet is too far away from Sensor
- Bad receiver connection
- Sensor battery low

Board stays down all the time and can be moved by hand:

- Gear shaft wedge screw is missing or loose

Board shakes and or shutters during operation:

- Bad ground
- Wire connections not secure
- Bad battery connection
- Links misaligned

Delay in board operation or boards operate after doors are shut:

- Magnet is too far away from Sensor
- Sensor battery low

Board hits body

- Install supplied adhesive bumper per the installation instructions.

Board does not fully retract or deploy

- The board is designed to stop travel when the system senses a load. Misalignment can cause the board to stop early. Remove the motor and adjust the linkage alignment until the board moves up and down freely without resistance by hand.

Board retracts when doors are left open for a long period of time.

- This is normal to save sensor battery life.

PowerBoard® NX Service Tips

Adjusting Linkage alignment:

The board is designed to stop travel when the system senses a load. Misalignment can cause the board to stop early.

To adjust, remove running board and motor. Loosen mounting brackets. Adjust linkages parallel to each other. Shift the running board on linkages 1/8" in either direction and carefully set board on linkages. Start only a few threads of the allen head bolts – do not tighten yet. Lift running board to retracted position. Tighten allen head bolts that attach running board to linkage. Last, tighten linkages to body. Cycle running board by hand without motor and confirm zero resistance. Install motor and test.

PowerBoard® NX – Installation Instructions

Linkage Component Identification

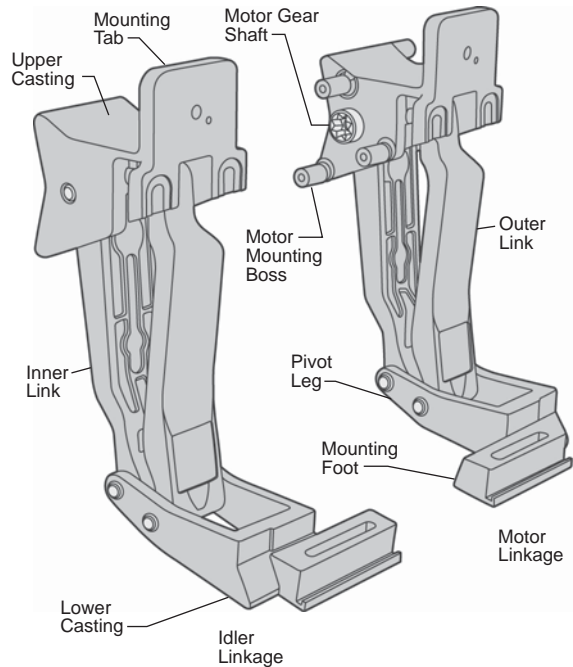

Battery Replacement

Each sensor is powered by a CR2450 3 volt battery that may periodically need to be replaced.

1. Remove the PowerBoard® fuse that is next to the car battery.
2. Remove the two screws and the cover plate on the sensor. Slide out the circuit board and note the orientation of the board. Replace the battery and slide the board back into the housing with its original orientation. Leave the vehicle door or doors open.
3. Reinstall the PowerBoard® fuse and wait 30 seconds. The sensor is reprogramming its address during this time.
4. Shut the door(s). Open and close the doors(s) to check for normal operation.

If opening a door fails to operate the PowerBoard, open the appropriate door and remove the PowerBoard® fuse. Wait 30 seconds and the reprogramming will repeat. Reinstall the fuse and check for normal operation.

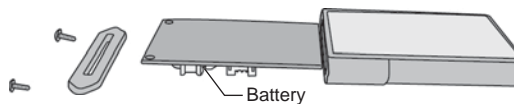

This device complies with Industry Canada licence-exempt RSS standard(s). Operation is subject to the following two conditions: (1) this device may not cause interference, and (2) this device must accept any interference, including interference that may cause undesired operation of the device.

Le présent appareil est conforme aux CNR d'Industrie Canada applicables aux appareils radio exempts de licence. L'exploitation est autorisée aux deux conditions suivantes: (1) l'appareil ne doit pas produire de brouillage, et (2) l'utilisateur de l'appareil doit accepter tout brouillage radioélectrique subi, même si le brouillage est susceptible d'en compromettre le fonctionnement.

This device complies with Part 15 of the FCC Rules. Operation is subject to the following two conditions:

- (1) This device may not cause harmful interference
- and
- (2) This device must accept any interference received, including interference that may cause undesired operation.

The user is cautioned that changes or modifications not expressly approved by the party responsible for compliance could void the user's authority to operate this equipment.

PowerBoard® NX – Installation Instructions

Care and Maintenance

The step pad surface and linkage arms should be washed with mild soap and water using a soft brush or sponge to dislodge any mud, dirt or accumulated road grime. Rinse with fresh water and avoid spraying the motors directly. After it is dry, lubricate the hinge with 3-IN-ONE Oil.

To prevent slipping, avoid applying waxes, lubricants or protectants like Armor All® to the step surface.

Attention!

TrekStep™ SHOULD ALWAYS BE STOWED IN THE RETRACTED POSITION WHEN DRIVING.

LIMITED WARRANTY

We warrant our product to be free from defects in material and workmanship, for the terms specified below, provided there has been normal use and proper maintenance. This warranty applies to the original purchaser only. All remedies under this warranty are limited to the repair or replacement of any item or items found by the factory to be defective within the time period specified. If you have a warranty claim, first you must call our factory at the number below for instructions. You must retain proof of purchase and submit a copy with any items returned for warranty work. Upon completion of warranty work, if any, we will return the repaired or replaced item or items to you freight prepaid. Damage to our products caused by accidents, fire, vandalism, negligence, misinstallation, misuse, Acts of God, or by defective parts not manufactured by us, is not covered under this warranty.

THE WARRANTY TIME PERIOD IS AS FOLLOWS FOR ALL PowerBoards® MANUFACTURED BY OUR COMPANY: THREE YEARS / 36,000 MILES FROM DATE OF PURCHASE.

ANY IMPLIED WARRANTIES OF MERCHANTABILITY AND/OR FITNESS FOR A PARTICULAR PURPOSE CREATED HEREBY ARE LIMITED IN DURATION TO THE SAME DURATION AND SCOPE AS THE EXPRESS WRITTEN WARRANTY. OUR COMPANY SHALL NOT BE LIABLE FOR ANY INCIDENTAL OR CONSEQUENTIAL DAMAGE.

Some states do not allow limitations on how long an implied warranty lasts, or the exclusion or limitation of incidental or consequential damages, so the above limitations or exclusions may not apply to you. This warranty gives you specific legal rights, and you may also have other rights which vary from state to state.



For further information or request for warranty work, please contact:
Bestop Inc. Customer Service
Toll-Free: (800)845-3567
Main: (303)465-1755
E-mail: csbestop@Bestop.com
Website: www.Bestop.com