



# Installation Instructions

## PowerBoard® NX

Automatic Retracting Running Board

### Vehicle Application

- Ford F150 Crew Cab
- 2009 – Current
- Part Number: 75641-15

Patent Pending

[www.Bestop.com](http://www.Bestop.com) - We're here to help! Visit our web site and click on ["Ask a Question"](#). Click here for more [Truck Accessories by Bestop](#).

<b>INSTALLATION TIME</b>		<b>SKILL LEVEL</b>	
<p><b>3 Hours</b></p>		<p><b>3 - Moderately Difficult</b></p>	
<b>TOOLS</b>			
<p>Tape Measure</p>	<p>Flat-Head Screwdriver</p>	<p>Phillips Screwdriver</p>	<p>Wrench 13mm</p>
			<p>Socket 8mm, 10mm &amp; 13mm</p>
<p>Ratchet</p>	<p>Extension</p>	<p>Allen Wrench 5 mm</p>	<p>Crimp Tool</p>
			<p>Torque Wrench</p>
<p>Safety Glasses</p>			



- ! WARNING** The manufacturer strongly recommends that this product be professionally installed.
- ! WARNING** Failure to carefully follow the electrical installation steps could result in severe electrical shock which could harm the installer and/or damage the vehicle.

**! WARNING** This product is designed primarily to enhance the appearance of the vehicle and to shield the occupants from ordinary weather conditions. Do not rely in any way on the components of this product to contain occupants within the vehicle, or to protect against injury or death in the event of an accident. This product will not protect the occupants from falling objects. Never operate the vehicle in excess of manufacturer's specifications.

**WEAR SEAT BELTS AT ALL TIMES**

Read and follow, precisely, all installation instructions provided when installing product. Failure to do so may result in a poor fit and could place occupants of the vehicle in a potentially dangerous situation.

# PowerBoard® NX – Installation Instructions

## Parts List and Hardware Identification

Running Board Assembly, Qty - 2  
72" - Part Number 514.08  
79" - Part Number 514.07

Idle Linkage, Part Number 473.62, Qty - 2

Motor Linkage, Part Number 473.63, Qty - 2

Motor (for use with Blue Controller), Part Number 496.12, Qty - 2

Blue Controller, Part Number 496.11, Qty - 1

Light, Part Number 470.15, Qty - 4

Wireless Component Kit

- Sensor - Driver Side Front, Part Number 492.01, Qty - 1
- Sensor - Passenger Side Front, Part Number 492.00, Qty - 1
- Sensor - Driver Side Rear, Part Number 492.03, Qty - 1
- Sensor - Passenger Side Rear, Part Number 492.02, Qty - 1
- Receiver, Part Number 491.99, Qty - 1
- Magnet, Part Number 491.97, Qty - 5
- Magnet Holder, Part Number 491.98, Qty - 5
- 17" Nylon Zip Tie, Part Number 492.06, Qty - 2

M8 U-Nut, Part Number 460.98, Qty - 8

M8-1.25 x 30 Hex Bolt, Part Number 473.18, Qty - 8

M8-1.25 x 20 Hex Bolt, Part Number 460.46, Qty - 8

M6-1.0 x 35 Socket Cap Screw, Part Number 460.95, Qty - 6

M6-1.0 x 20 Socket Head Bolt, Part Number 470.00, Qty - 8

Small Washer, Part Number 470.05, Qty - 16

M6 Flat Washer, Part Number 481.96, Qty - 6

PSA Bumper, Part Number 475.43, Qty - 4

7" Cable Ties, Part Number 460.99, Qty - 25

11" Cable Ties, Part Number 470.02, Qty - 2

Wiring Harness, Part Number 495.57, Qty - 1

# PowerBoard® NX – Installation Instructions

## RF System Overview

The PowerBoards® are activated by Sensors that are to be mounted inside the door openings for each door. The Sensors are off when a magnet is next to the Sensor end that has the two screws. The Sensor triggers the PowerBoards® to deploy when the magnet is moved about 3 inches away from the Sensor. The magnet can work in either of the locations shown to signal the PowerBoards® to retract.

Be sure to mount the Sensors in a location that will allow removal of the screws for battery replacement. See Battery Replacement at the end of the instructions.

See Steps 12 – 18 for detailed instructions.

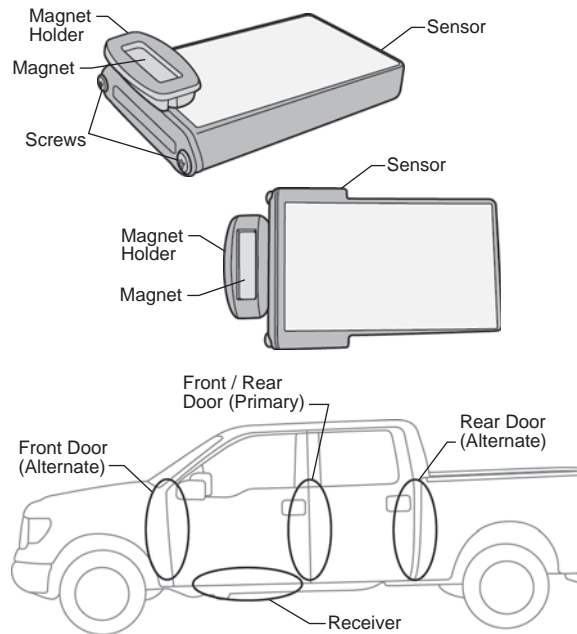

## 1 System Initialization

- Remove fuse from the PowerBoard® wire harness and connect the red lead to the battery positive and the black lead to negative.
- Layout the harness so the long leg crosses the engine compartment towards the drivers side and the short leg is on the passenger side.
- Attach a motor to each motor link with 3 M6-1.0 x 35mm Socket Cap Screws.
- Plug the Controller, Receiver, Motors and Lights into the harness.
- Plug the fuse back into the harness. After a one second delay the linkages will retract as shown.
- Lay out all four sensors as they would be installed on the vehicle with the drivers side to your left and the passengers side to your right. Place a magnet next to each sensor as shown in the overview above.
- Move the magnet more than 4 inches away from the driver front sensor. All four lights will come on and the drivers side linkage will deploy.
- Move the magnet back to the sensor and after a three second delay the lights will turn off and the linkage will retract.
- Repeat with the remaining sensors and the lights and corresponding linkage will operate in the same manner.
- Remove the motors to continue with the installation.

If the system does not operate as stated above see the Troubleshooting and Battery Replacement sections at the end of the instructions or go to our web site at <http://www.bestop.com/support>.

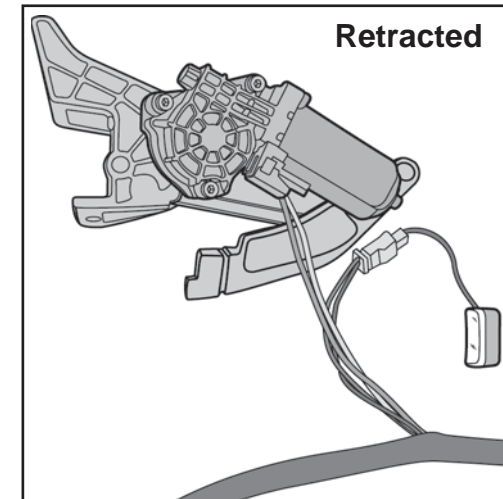
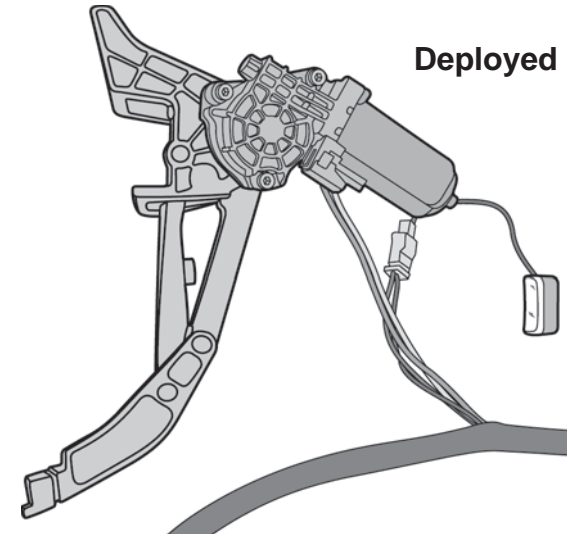

# PowerBoard® NX – Installation Instructions

## 2 Install Mounting Clips - Driver's Side

Counting from the front, locate the first (1st) and last set of mounting holes on the inner sill. Use an M8-1.25 x 30 Hex Bolt and a Small Washer to install a Mounting Clip on each side of each hole. Do not tighten the bolts at this time.

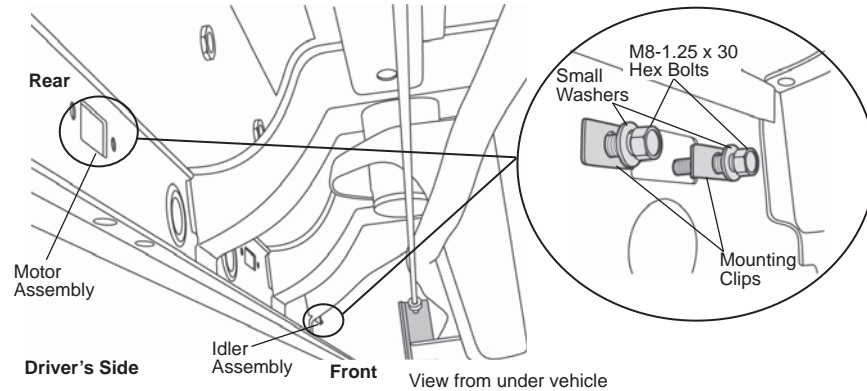

## 3 Install Linkages

Mount the Motor Linkage to the rear and the Idler Linkage to the front on both sides of the vehicle. Slip the notches in the Arms under the bolts and washers installed in Step One.

**Finger tighten fasteners at this time.**

Secure the bottom of the Arms with two M8-1.25 x 20 Hex Bolts and Small Washers. **Do not tighten the bolts yet.**

The Motor Linkage mounts toward the rear of the truck, except for the passenger side on SuperCab vehicles.

**NOTE** If the sheet metal holes are misaligned, you may need to file off the edge of the sheet metal.

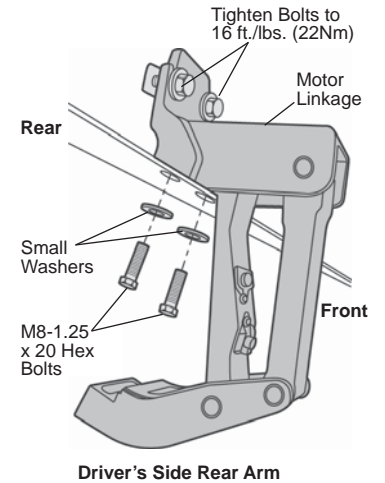

**! WARNING** Remove the fuse from the Wiring Harness.

## 4 Remove Fuse from Wiring Harness

Remove the fuse from the Wiring Harness. Failure to do so could result in severe electrical shock which could harm the installer and/or damage the vehicle.

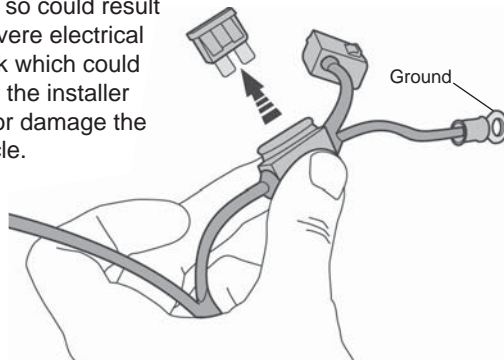

## 5 Install Controller and Wiring Harness

Connect the Wiring Harness to the Controller. Make sure that the locking tabs are fully engaged.

Use the 11" Cable Ties to mount the Controller to the factory conduit.

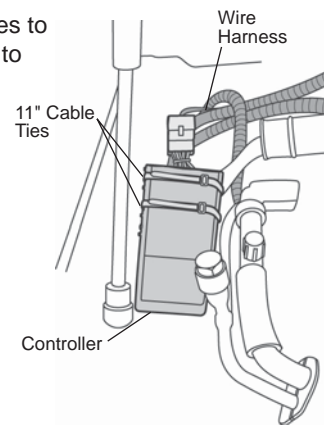

## 6 Connect Wiring Harness to Battery

Connect the red power lead to the positive battery terminal and the black lead to the negative terminal. (Skip if still attached from Step 1.)

Route the shorter leg of the harness to the wheel well on the passenger's side. Use the 7" Cable Ties to secure the harness.

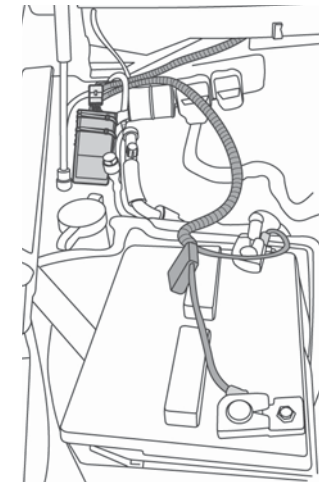

# PowerBoard® NX – Installation Instructions

**CAUTION** Do Not install on or near hot surfaces.

## 7 Route Wiring Harness

Route the long leg of the Wiring Harness across the firewall through the plastic cowl and down to the driver's side wheel well. Continue along the frame. Use the 7" Cable Ties to secure the harness along the way.

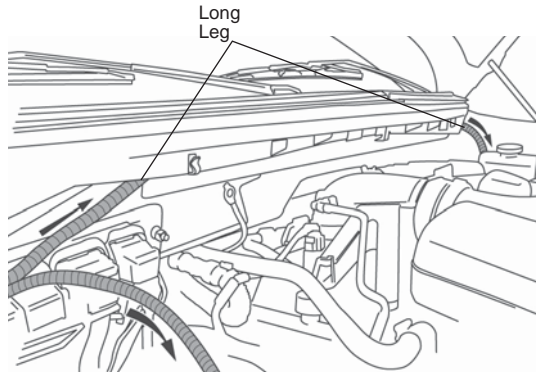

## 8 Install Receiver

Route the small diameter wire harness along the side of the frame. Find a location that is protected but is not surrounded by dense metal. Plug in the Receiver and insert 17" Nylon Zip Ties through the loops on the Receiver. Mount the Receiver with the stand off ribs against the vehicle.

**NOTE** Due to vehicle variations, installation may differ from that shown.

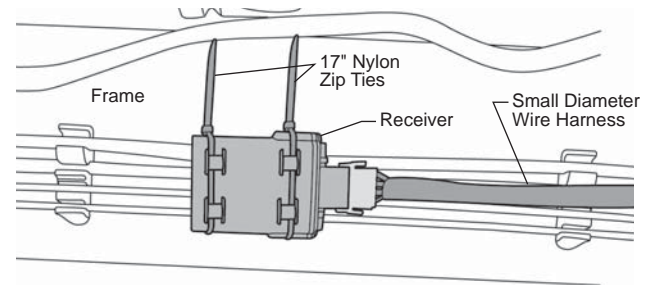

## 9 Install Running Boards

Mount the Steps to the linkages. Slide the mounting T-Nut into position. Install M6-1.0 x 20mm Socket Head Bolts to secure the boards. Use a 5mm Allen Wrench to tighten the bolts.

Make sure the board moves up and down freely by hand. If it binds, loosen the linkage to body attachment bolts and adjust the linkage position until the boards move freely. **Do not tighten the bolts at this time.**

**NOTE** Tightening the fasteners before cycling the step several times may create a bind, causing a squeaking sound and preventing the boards from retracting completely and evenly.

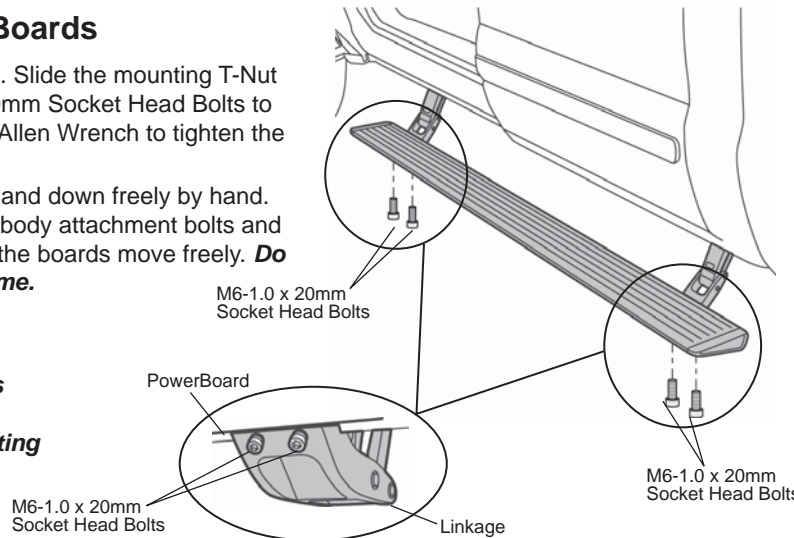

## 10 Install Motor

Slide Motor assembly onto drive shaft and mounting bosses of Motor Linkage assembly. Use three (3) M6-1.0 x 35mm Socket Cap Screws and M6 Flat Washers to secure Motor. Plug female connector into Motor.

**Torque**  
5-7 ft. lbs.  
(6.78-9.49 Nm / 60-84 in. lbs.)  
Do not exceed 7 ft. lbs. of torque

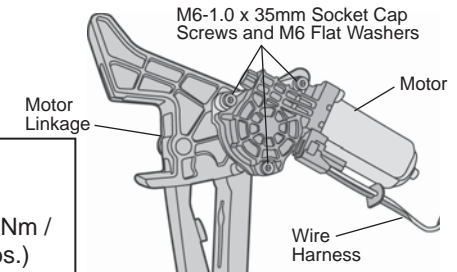

# PowerBoard® NX – Installation Instructions

## 11 Install Magnet

Open the back door on the driver's side and clean the area where the magnet and sensor will be installed with a 50/50 solution of water and alcohol. Stick a magnet to the back side of the front door as shown. Hold the Drivers Front Sensor against the door pillar and position the magnet so it is directly in front of the sensor.

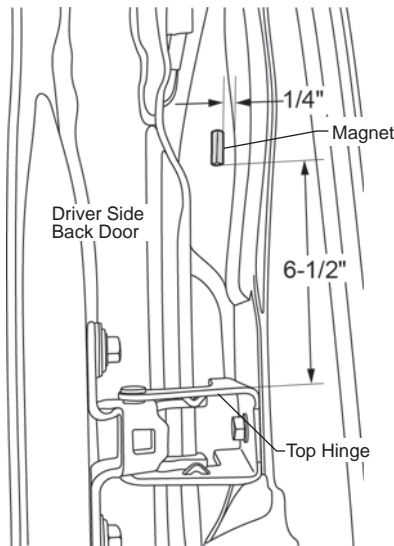

## 12 Install Driver's Side Front Sensor

Peel the liner off of the Drivers Side Front Sensor. Position it on the door pillar so it is about 1/6" away from the magnet. Press firmly on the Sensor to stick it to the pillar.

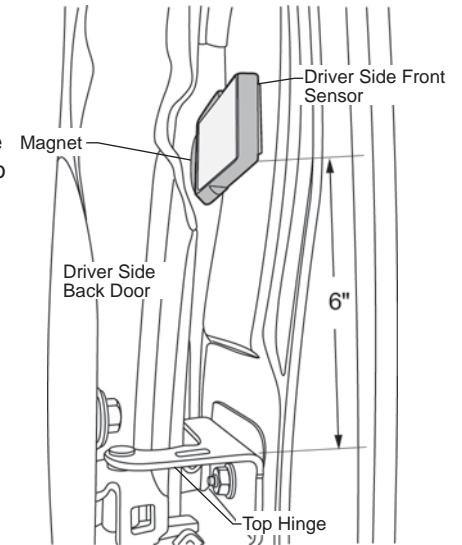

## 13 Install Magnet

Open the front driver's side door and clean the area where the magnet and sensor will be installed with a 50/50 solution of water and alcohol. Stick a magnet to the front side of the rear door as shown. Hold the Drivers Rear Sensor against the door pillar and position the magnet so it is directly in front of the sensor.

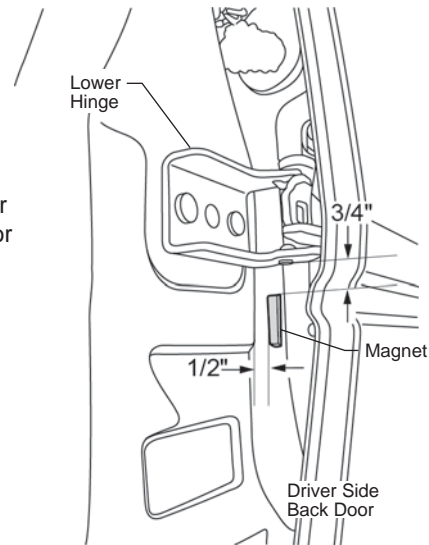

## 14 Install Driver's Side Rear Sensor

Peel the liner off of the Drivers Side Rear Sensor. Position it on the door pillar so it is about 1/6" away from the magnet. Press firmly on the Sensor to stick it to the pillar.

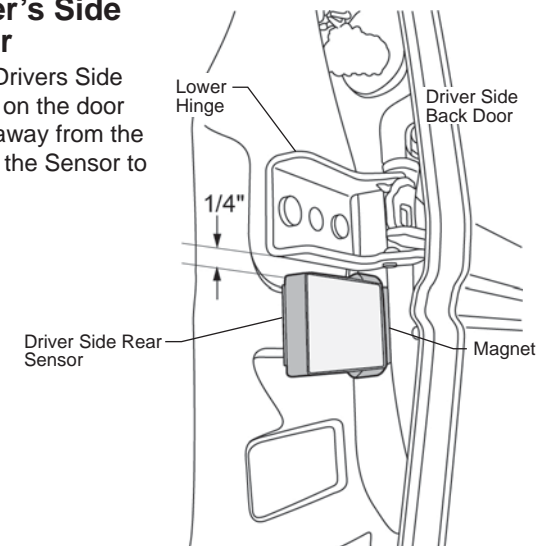

# PowerBoard® NX – Installation Instructions

## 15 Install Passenger Side Sensors and Magnets

Repeat Steps 11 through 14 on the passenger side of the vehicle.

## 16 Reinstall Fuse

Reinstall fuse in PowerBoard® wire harness.

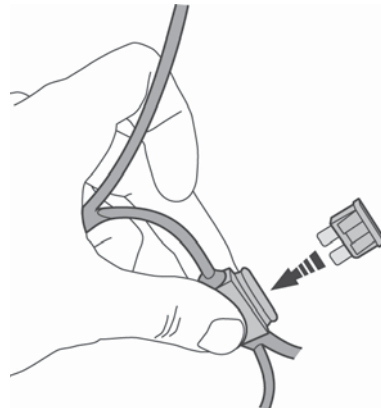

## 17 Test Doors and PowerBoards®

Open and shut each door to make sure the PowerBoards® deploy and retract. There is a slight delay in the board deployment so make sure they are fully down before stepping on them. There is also a 3-4 second delay in board retraction after the door is shut. This gives you time to open another door with out cycling the board again. **Cycle the boards several times and then fully tighten all of the fasteners.**

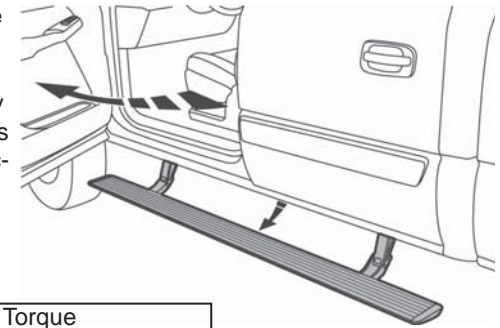

**CAUTION**

Never force the board up or down. Use the motors to cycle the board.

Torque  
5-7 ft. lbs.  
(6.78-9.49 Nm /  
60-84 in. lbs.)  
Do not exceed 7 ft.  
lbs. of torque

Order to tighten screws:  
Board to Linkage 1st  
Linkage to Body 2nd

## 18 Install Lights

Clean the outboard surface of the of the Linkage below the bottom mounting bolt. Peel the adhesive liner off the back of the Light and firmly press it 1/8" below the mounting bolt. Plug the light into the connector with the black and orange wires in the wire harness. Repeat with the other three lights. Secure loose wires with Cable Ties.

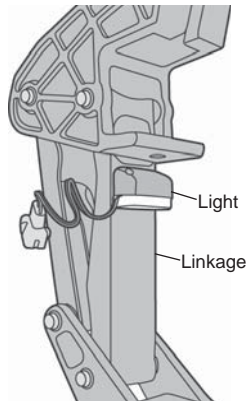

## 19 Install Magnet Holders

Peel the liner off the back of a magnet holder and place it around the magnet. Be careful not to move the magnet. Press firmly on the holder to stick it to the door.

Repeat for all Magnets.

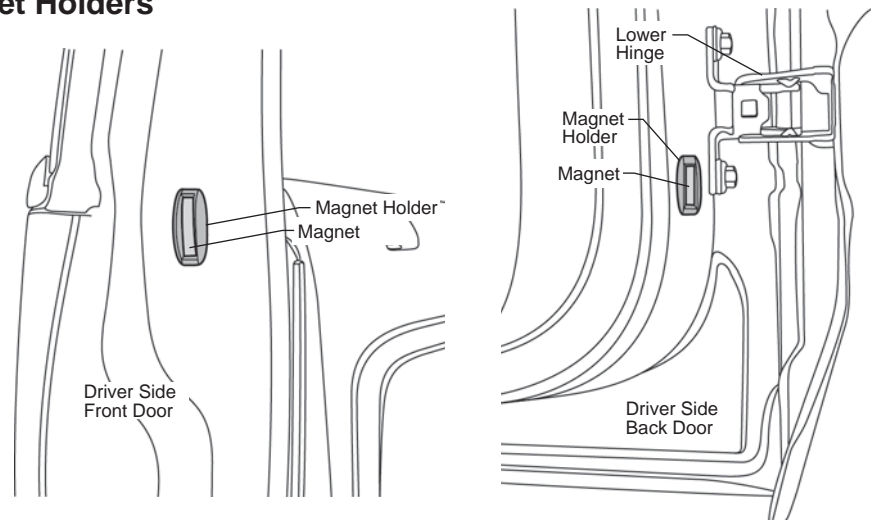

# PowerBoard® NX – Installation Instructions

## 20 Install PSA Bumper – Optional

Due to variations in vehicle build, the PowerBoards® may contact the vehicle body when in the up position. If you would like to stop the board's travel earlier, install the supplied PSA Bumpers to the inner links or stick the bumper to the body at the location of contact.

To stop the board travel earlier, look for the area on the inner link where the Stop Bumper on the outer link would make contact if the board did not stop early (see gap in illustration).

Open the door to lower the board. Stand on the board to keep it in the down position and shut the door. Remove the fuse. Peel the backing off of the PSA Bumper and stick it to the surface on the inner link where the Stop Bumper will contact it. Do this on both idler and motor links. Reinstall the fuse and check to make sure the Stop Bumper hits the PSA Bumper when the doors are shut.

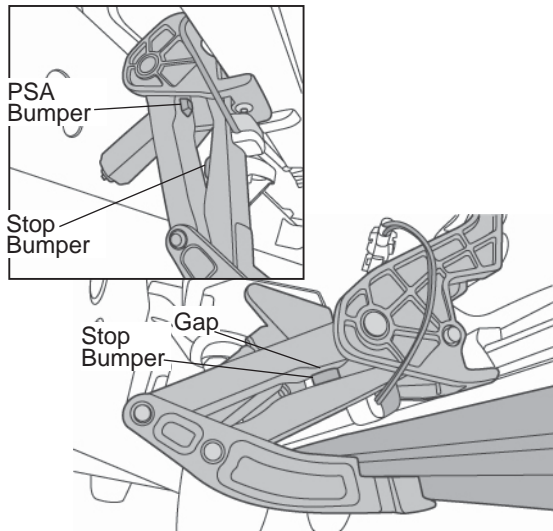

## Linkage Component Identification

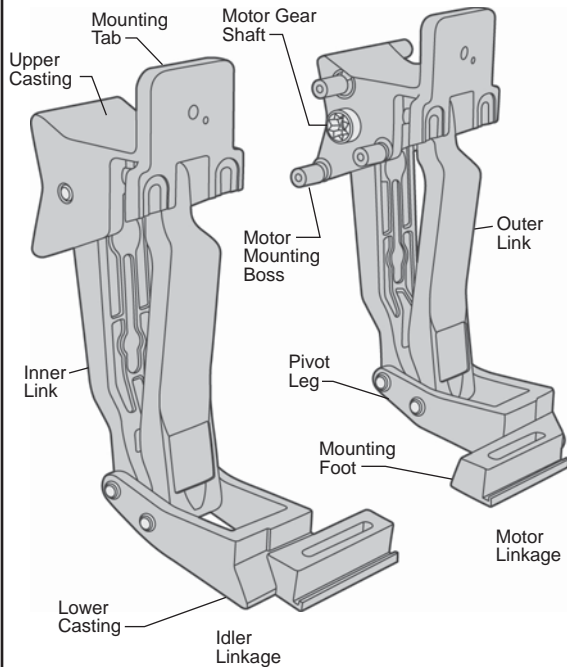



# PowerBoard® NX – Installation Instructions

## PowerBoard® NX Troubleshooting

### Issue:

- Possible cause

### Boards do not operate:

- Bad ground
- Bad battery connection
- Fuse burned
- Magnet is too far away from Sensor
- Bad receiver connection
- Sensor battery low

### Board creaks or squeaks during operation:

- Gear shaft wedge bolt is loose
- Loosen mounting bracket and board attachment screws. Adjust linkages so they are parallel to each other and the noise is gone. Tighten all fasteners.

### Intermittent operation:

- Bad battery connection
- Bad ground
- Magnet is too far away from Sensor
- Bad receiver connection
- Sensor battery low

### Boards operate randomly:

- Wire connections not secure
- Magnet is too far away from Sensor
- Bad receiver connection
- Sensor battery low

### Board stays down all the time and can be moved by hand:

- Gear shaft wedge screw is missing or loose

### Board shakes and or shutters during operation:

- Bad ground
- Wire connections not secure
- Bad battery connection
- Links misaligned

### Delay in board operation or boards operate after doors are shut:

- Magnet is too far away from Sensor
- Sensor battery low

### Board hits body

- Install supplied adhesive bumper per the installation instructions.

### Board does not fully retract or deploy

- The board is designed to stop travel when the system senses a load. Misalignment can cause the board to stop early. Remove the motor and adjust the linkage alignment until the board moves up and down freely without resistance by hand.

### Board retracts when doors are left open for a long period of time.

- This is normal to save sensor battery life.

## PowerBoard® NX Service Tips

### Adjusting Linkage alignment:

The board is designed to stop travel when the system senses a load. Misalignment can cause the board to stop early.

To adjust, remove running board and motor. Loosen mounting brackets. Adjust linkages parallel to each other. Shift the running board on linkages 1/8" in either direction and carefully set board on linkages. Start only a few threads of the allen head bolts – do not tighten yet. Lift running board to retracted position. Tighten allen head bolts that attach running board to linkage. Last, tighten linkages to body. Cycle running board by hand without motor and confirm zero resistance. Install motor and test.

## Battery Replacement

Each sensor is powered by a CR2450 3 volt battery that may periodically need to be replaced.

1. Remove the PowerBoard® wire harness fuse that is next to the car battery.
2. Remove the two screws and the cover plate on the sensor. Slide out the circuit board and note the orientation of the board. Replace the battery and slide the board back into the housing with its original orientation. Leave the vehicle door or doors open.
3. Reinstall the PowerBoard® fuse and wait 30 seconds. The sensor is reprogramming its address during this time.
4. Shut the door(s). Open and close the doors(s) to check for normal operation.

If opening a door fails to operate the PowerBoard, open the appropriate door and remove the PowerBoard® fuse. Wait 30 seconds and the reprogramming will repeat. Reinstall the fuse and check for normal operation.

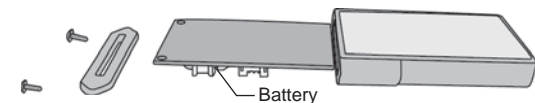

## PowerBoard® NX – Installation Instructions

This device complies with Industry Canada licence-exempt RSS standard(s). Operation is subject to the following two conditions: (1) this device may not cause interference, and (2) this device must accept any interference, including interference that may cause undesired operation of the device.

Le présent appareil est conforme aux CNR d'Industrie Canada applicables aux appareils radio exempts de licence. L'exploitation est autorisée aux deux conditions suivantes: (1) l'appareil ne doit pas produire de brouillage, et (2) l'utilisateur de l'appareil doit accepter tout brouillage radioélectrique subi, même si le brouillage est susceptible d'en compromettre le fonctionnement.

This device complies with Part 15 of the FCC Rules.

Operation is subject to the following two conditions:

- (1) This device may not cause harmful interference and
- (2) This device must accept any interference received, including interference that may cause undesired operation.

The user is cautioned that changes or modifications not expressly approved by the party responsible for compliance could void the user's authority to operate this equipment.

### Care and Maintenance

The step pad surface and linkage arms should be washed with mild soap and water using a soft brush or sponge to dislodge any mud, dirt or accumulated road grime. Rinse with fresh water and avoid spraying the motors directly. After it is dry, lubricate the hinge with 3-IN-ONE Oil.

To prevent slipping, avoid applying waxes, lubricants or protectants like Armor All® to the step surface.

#### Attention!

TrekStep™ SHOULD ALWAYS BE STOWED IN THE RETRACTED POSITION WHEN DRIVING.

### LIMITED WARRANTY

We warrant our product to be free from defects in material and workmanship, for the terms specified below, provided there has been normal use and proper maintenance. This warranty applies to the original purchaser only. All remedies under this warranty are limited to the repair or replacement of any item or items found by the factory to be defective within the time period specified. If you have a warranty claim, first you must call our factory at the number below for instructions. You must retain proof of purchase and submit a copy with any items returned for warranty work. Upon completion of warranty work, if any, we will return the repaired or replaced item or items to you freight prepaid. Damage to our products caused by accidents, fire, vandalism, negligence, misinstallation, misuse, Acts of God, or by defective parts not manufactured by us, is not covered under this warranty.

THE WARRANTY TIME PERIOD IS AS FOLLOWS FOR ALL PowerBoards® MANUFACTURED BY OUR COMPANY: THREE YEARS / 36,000 MILES FROM DATE OF PURCHASE.

ANY IMPLIED WARRANTIES OF MERCHANTABILITY AND/OR FITNESS FOR A PARTICULAR PURPOSE CREATED HEREBY ARE LIMITED IN DURATION TO THE SAME DURATION AND SCOPE AS THE EXPRESS WRITTEN WARRANTY. OUR COMPANY SHALL NOT BE LIABLE FOR ANY INCIDENTAL OR CONSEQUENTIAL DAMAGE.

Some states do not allow limitations on how long an implied warranty lasts, or the exclusion or limitation of incidental or consequential damages, so the above limitations or exclusions may not apply to you. This warranty gives you specific legal rights, and you may also have other rights which vary from state to state.

For further information or request for warranty work, please contact:  
Bestop Inc. Customer Service  
Toll-Free: (800)845-3567  
Main: (303)465-1755  
E-mail: [csbestop@Bestop.com](mailto:csbestop@Bestop.com)  
Website: [www.Bestop.com](http://www.Bestop.com)

