



Installation Instructions

Fabric Replacement Top with Tinted Side and Rear Windows

Upper Door Skins not included



Vehicle Application

- Jeep Wrangler Unlimited TJ
2004 – 2006
Part Number: 79140

www.Bestop.com - We're here to help! Visit our web site and click on ["Ask a Question"](#). Click here for more [Jeep Accessories by Bestop](#).

INSTALLATION TIME	SKILL LEVEL
 <p>1 1/2 Hours</p>	 <p>2 - Moderately Easy</p>



TOOLS	
 <p>Phillips Screwdriver</p>	 <p>Safety Glasses</p>

 **CAUTION** Safety glasses should be worn at all times while installing this product.

Installation Tips
Before you begin installing this assembly, read all instructions thoroughly.

For a smooth fit:
For ease in installation, the product should be installed at temperatures above 72° F. Below this temperature, the fabric may contract an inch or more, making it difficult to fit to the vehicle. It is normal for fabric to contract and wrinkle when stored in the shipping carton. Within a few days after the installation, the fabric will relax and the wrinkles will disappear.

 **WARNING** This product is designed primarily to enhance the appearance of the vehicle and to shield the occupants from ordinary weather conditions. Do not rely in any way on the components of this product to contain occupants within the vehicle, or to protect against injury or death in the event of an accident. This product will not protect the occupants from falling objects. Never operate the vehicle in excess of manufacturer's specifications.

WEAR SEAT BELTS AT ALL TIMES

Read and follow, precisely, all installation instructions provided when installing product. Failure to do so may result in a poor fit and could place occupants of the vehicle in a potentially dangerous situation.

Fabric Replacement Top – Installation Instructions

Parts List

Fabric Top	Qty - 1
Quarter Window, Right	Qty - 1
Quarter Window, Left	Qty - 1
Rear Window	Qty - 1
Elastic Garter	Qty - 2

1 Remove Quarter Windows and Rear Window

Remove the Quarter Windows and the Rear Window. Remove the metal Tailgate Bar from the bottom of the Rear Window and set it aside. Release the plastic strip sewn to the top above the doors. Pull down and out to slip the plastic out of the channel.

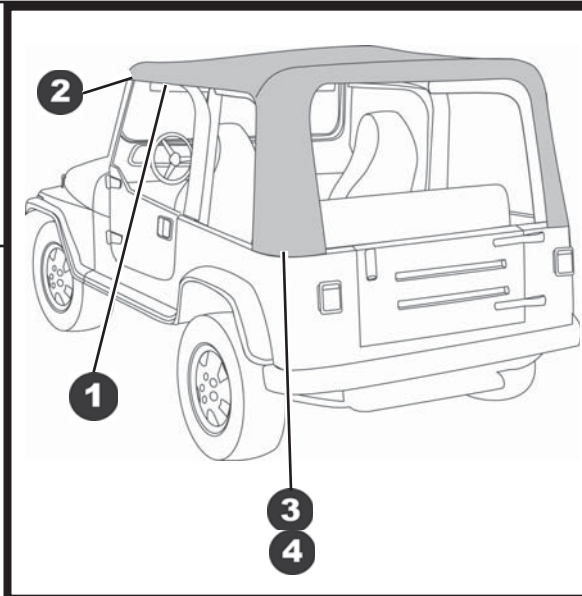
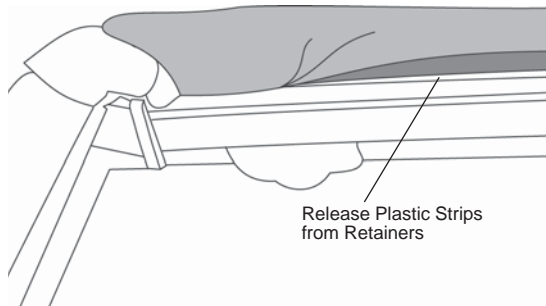

2 Release Windshield Latches

Release the latch that secures the header to the windshield. Pull up on the lever and then down and out to release the hook from the slot in the windshield frame.

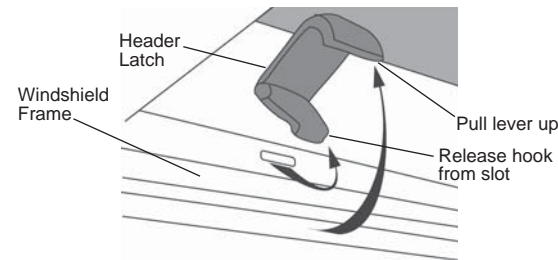

3 Remove Plastic Corner Stiffener

Locate the zipper inside the rear corner of the top. Open the zipper and remove the plastic stiffener in the pocket. Set the reinforcement aside to be reused later. Repeat this on both sides of the vehicle.

NOTE If you need to replace the stiffeners (Part Number 396.04P), please contact Bestop Customer Service for purchase information at 1-800-845-3567.

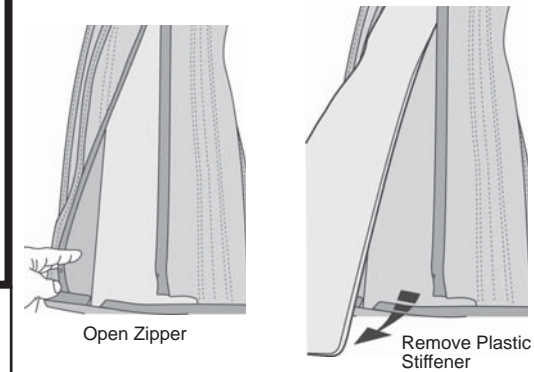

4 Release Rear Corners

Release the rear corners of the top. Pull gently down and then out to release the plastic strip from the retainer on the vehicle.

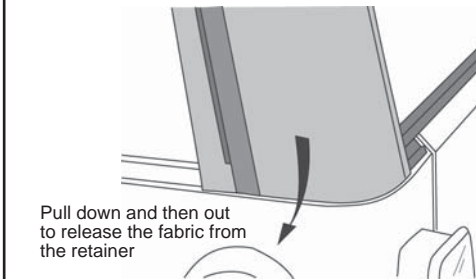

Fabric Replacement Top – Installation Instructions

5 Release Rear Bow

Use a phillips screwdriver to remove the four screws that attach the flap in the top to the rear bow. Set the screws aside to be reused later. Allow the bow to drop onto the tailgate.

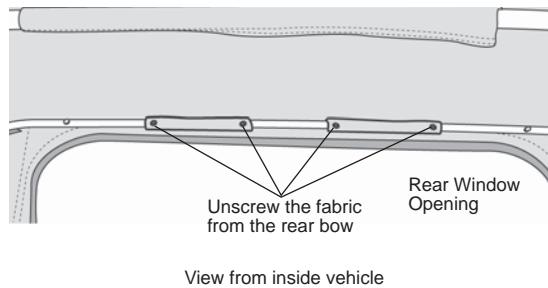

6 Unfasten Center Bows

Unfasten the hook and loop flaps around the Bows on each side of the sport bar.

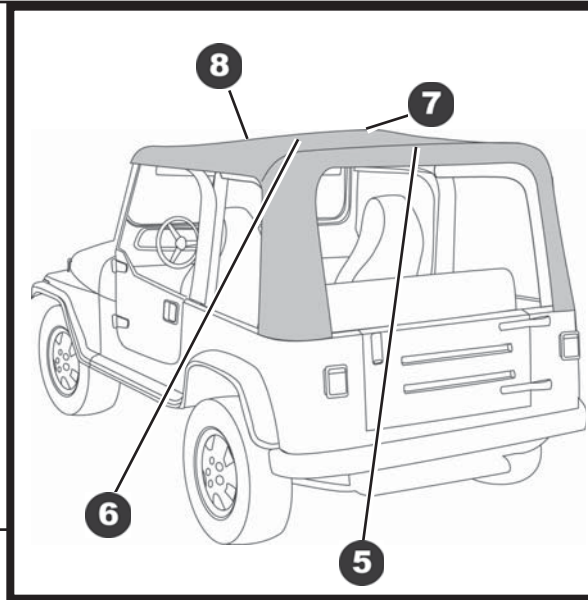
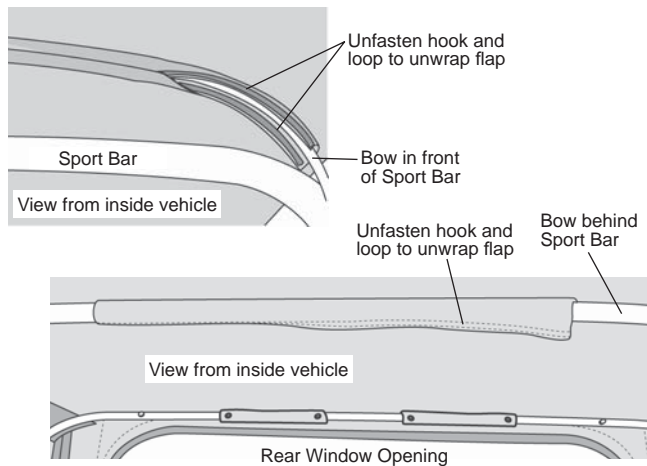

7 Remove Corner Screws

Collapse the bow assembly down onto the tailgate. With the bow assembly laying on the tailgate, remove the screws that fasten the fabric to the corners of the header. Set the screws aside for use in installing the new top fabric.

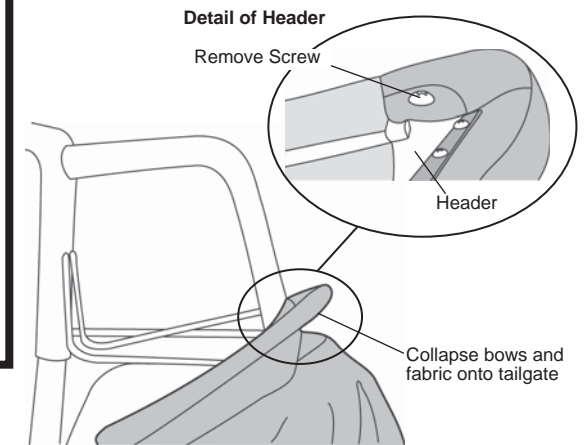

8 Remove Screws Holding Fabric to Header

Remove the eight screws that secure the fabric to the header. Set the screws aside for use in installing the new top. Then remove the old top fabric from the vehicle.

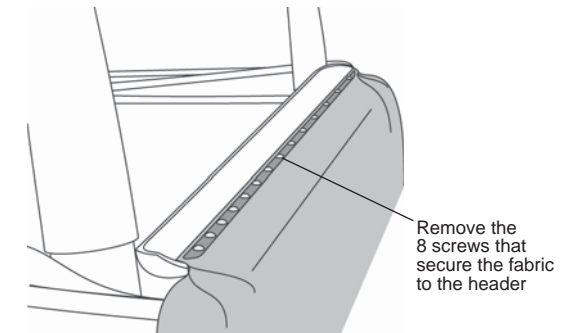

Fabric Replacement Top – Installation Instructions

9 Attach Top to Rear Bow

Orient the Replacement Top fabric on the vehicle. Raise the header and bow slightly to allow you to attach the rear bow flaps, that are inside the top above the rear window opening, to the rear bow. Use the four (4) screws that were removed in Step 5 to secure the flaps to the bow.

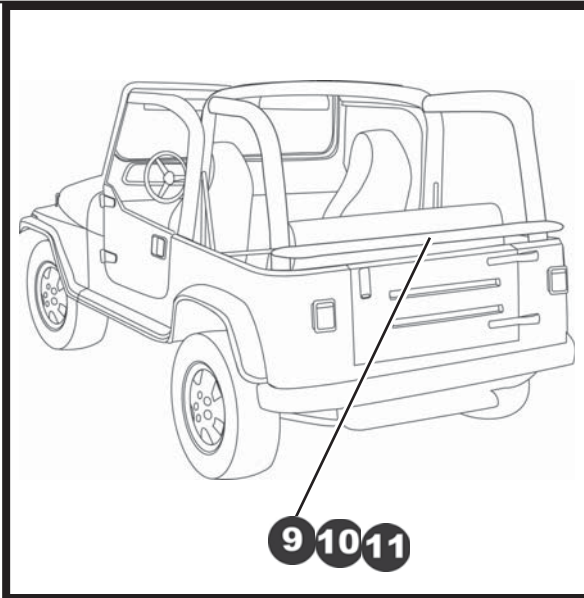
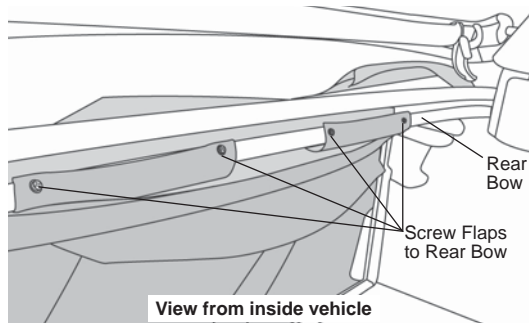

11 Install Top Fabric on Header

In order to install the top fabric, make sure that all the Bows are in the folded down position on the rear of the vehicle.

Lay the top fabric with the plastic strip facing up and aligned with the front edge of the header. Locate the round hole that marks the center of the plastic strip (all other holes are slotted). Install a screw in the round hole to secure the fabric to the header as well as to center the top. Then proceed to install screws in the remaining seven holes along the front of the header.

Detail of Center Screw Hole

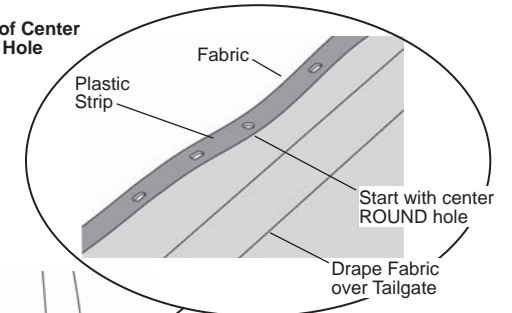

10 Secure Center Bows

Wrap the hook and loop flaps around the two Bows in the center of the top.

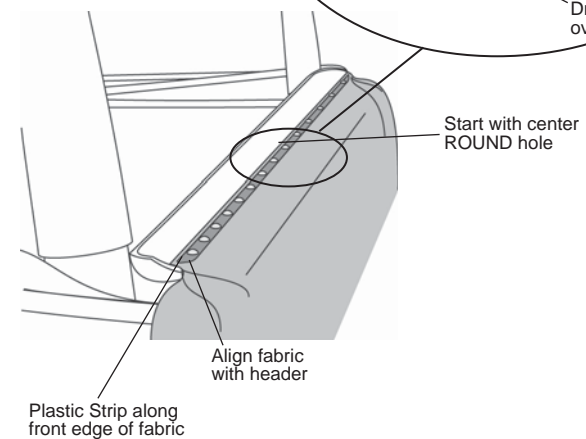
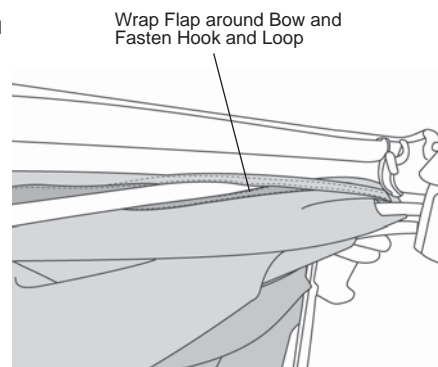
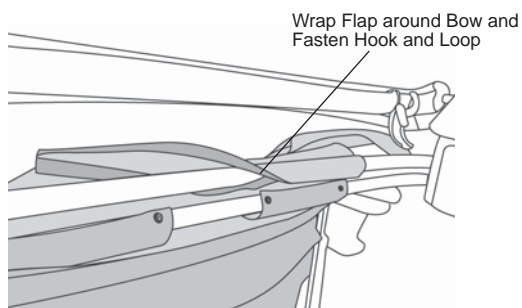

Fabric Replacement Top – Installation Instructions

12 Install Corner Screws

Wrap the fabric around the header and raise the header slightly to work the pockets in the fabric over the corners of the header. Install one of the screws removed in Step 7 in each corner to secure the fabric to the header.

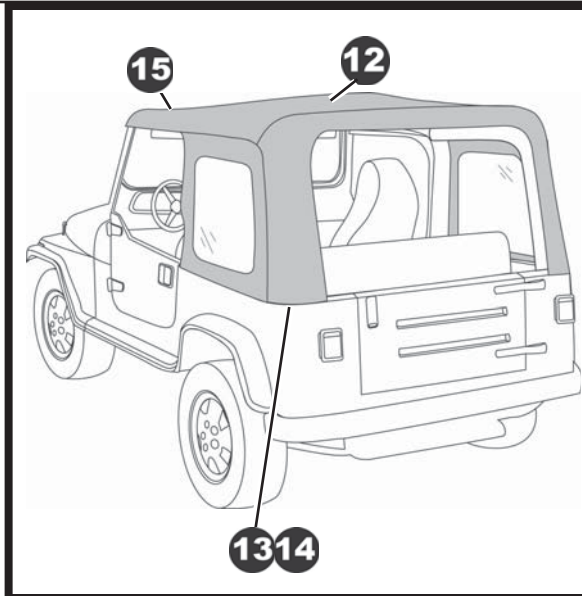
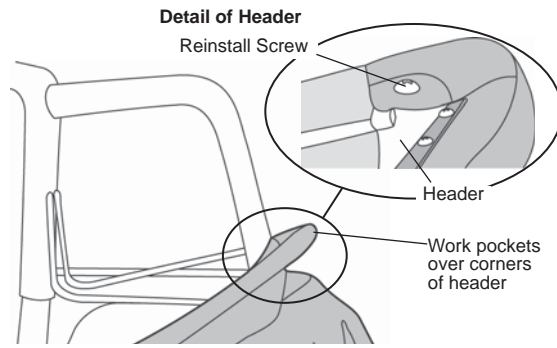

14 Secure Rear Corners

Pull down gently on the Rear Bow and work the plastic sewn to the rear corners of the top into the retainer on the vehicle.

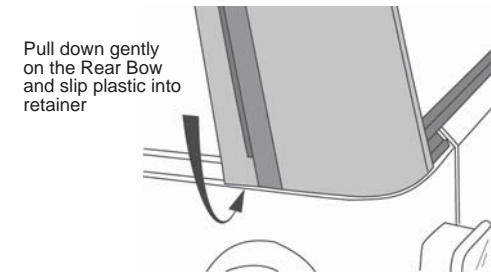

13 Install Plastic Corner Stiffeners

Open the zipper inside the rear corner of the top and install a plastic stiffener in the pocket. Repeat this on both sides of the vehicle.

NOTE If you need to replace the stiffeners (Part Number 396.04P), please contact Bestop Customer Service for purchase information at 1-800-845-3567.

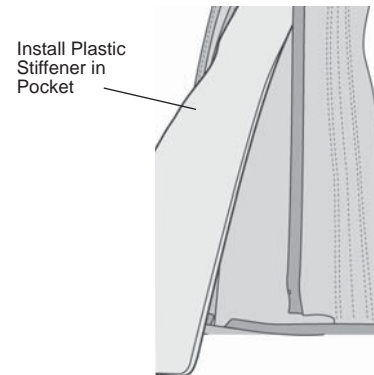

15 Secure Header to Windshield

Close the header latches to secure the front of the top to the windshield. Catch the hook in the slot in the windshield frame and then close the lever over it so that it lays flat against the windshield frame.

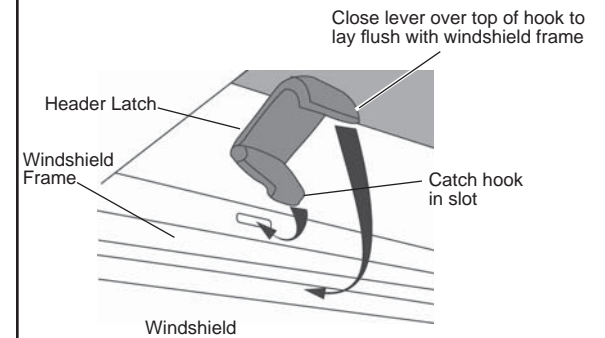

Fabric Replacement Top – Installation Instructions

16 Attach Quarter Panel Zippers

Locate the left and right Quarter Panels and orient them with the zipper along the top and rear of the panel. Start the zipper at the front top corner of the Quarter Panel, next to the door. Hold the end of the zipper and close the zipper slider 10" - 12" along the top of the panel.

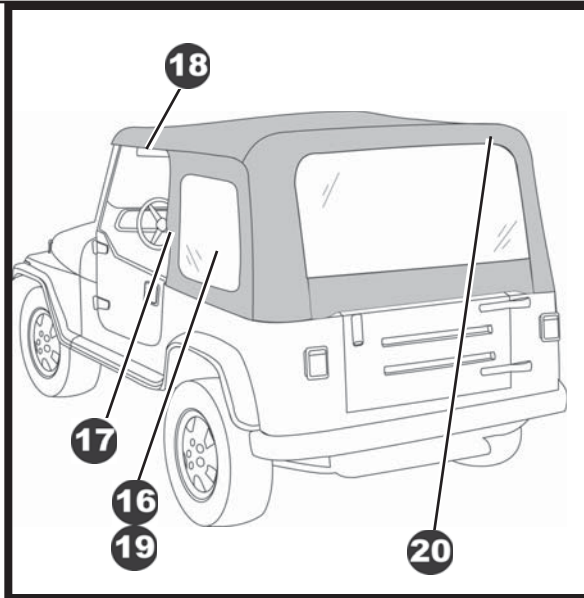
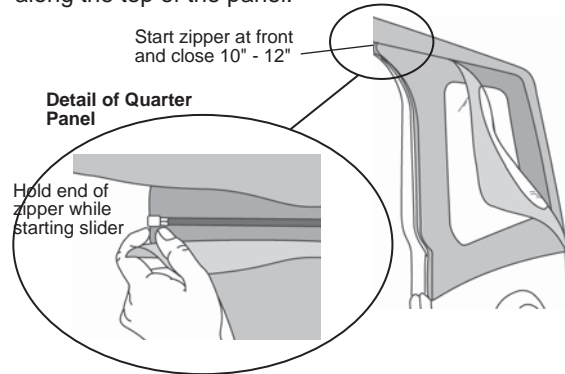

19 Secure Quarter Panels

Close the zippers on the Quarter Panels the rest of the way to the lower rear corner of the panel. Start at the rear and roll the plastic along the bottom of the panel into the retainer on the vehicle. Then fasten the hook and loop strips along the top and rear of the panel to the top.

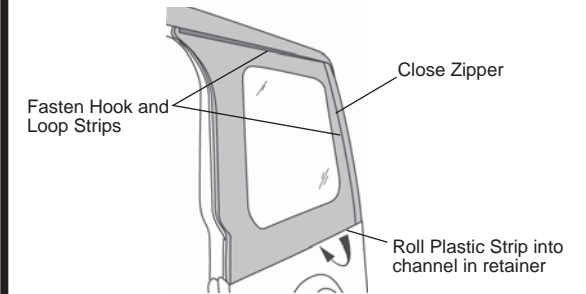

17 Secure Front of Quarter Panels

Roll the plastic along the front of the Quarter Panel into the channel of the Door Surround on the vehicle.

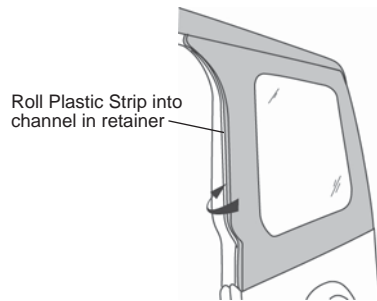

18 Secure Top above Door Openings

Locate the two plastic strips sewn to the sides of the top, above each door. Slip the strips into the channel in the Door Surround above the door opening. It is easiest to insert the front plastic strip into the channel first.

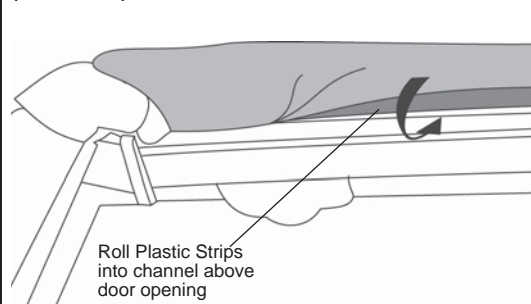

20 Install Elastic Garters

Snap the Elastic Garters to the snaps on the Rear Bow above the rear window opening.

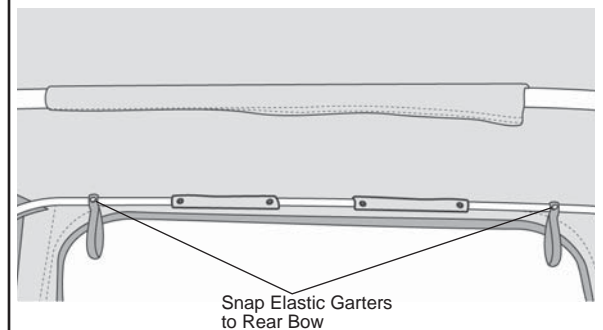

Fabric Replacement Top – Installation Instructions

21 Install Tailgate Bar on Rear Window

Remove the Rear Window from the box and lay it flat with the backing side up. Locate the Tailgate Bar set aside in Step One. The bar has a “C” shaped channel, when viewed from the end. Orient the bar with the round seal down and slide the “C” channel on the retainer onto the tubed strip sewn to the backing side of the Rear Window.

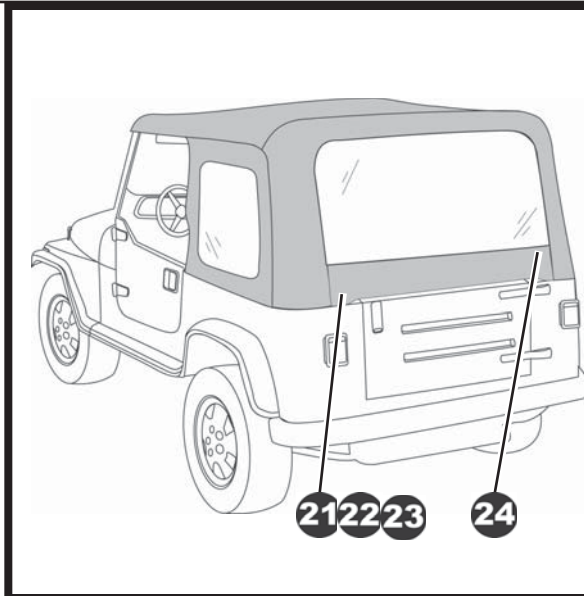
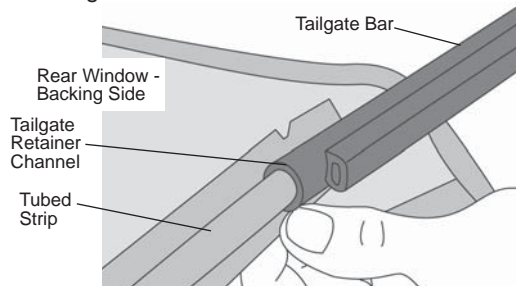

22 Install Tailgate Bar on Vehicle

Insert the Tailgate Bar into the mounts on each side of the tailgate opening with the vinyl side of the Rear Window toward the outside of the vehicle.

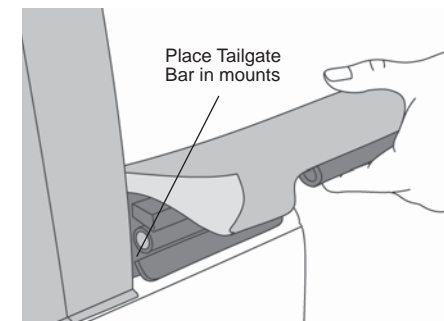

23 Secure Rear Window Zippers

To start the zipper, pull the two sliders as far down as possible on the driver's side of the window in order to catch the sliders to the pin. Once the zipper is caught, start the top slider 1/2". Then hold up the top of the window with one hand and close the zipper with the other. The zipper is sandwiched between layers of fabric in the corners so be careful not to catch extra fabric in the zipper. Close the zipper. Make sure that the Tailgate Bar is centered and is securely in the mounts. Then tuck the flaps on the Rear Window under the top fabric.

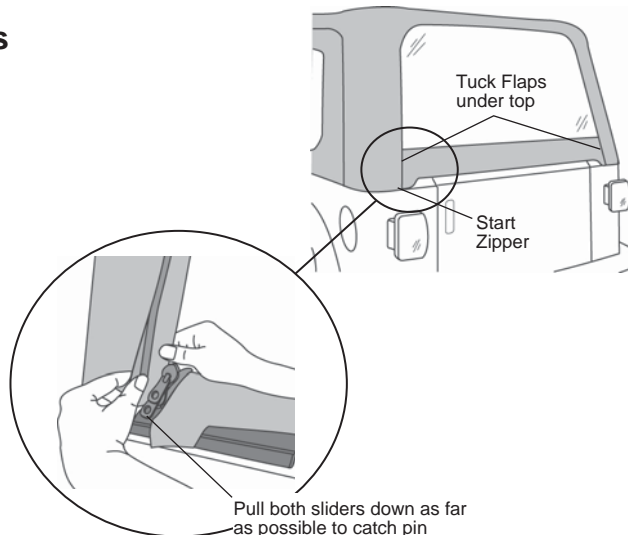

24 Secure Rear Window Flaps

Inside the top locate the flaps sewn to the top on each side of the rear window opening. Pull the flaps over to cover the zipper and tuck them in.

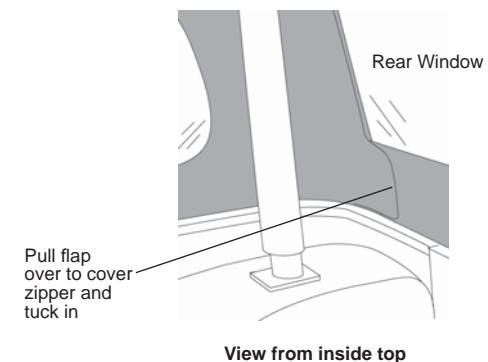

Fabric Replacement Top – Installation Instructions



WARNING

When operating the vehicle without the Quarter Windows, the Rear Window should be rolled up and secured with the elastic garters for proper ventilation.

25 To Fold the Top Down Remove Quarter Panels and Rear Window

Remove the Quarter Panels and the Rear Window. To remove the Quarter Windows, unzip the rear and top zippers. Release the plastic strip from the retainer. Release the Hook and Loop Fasteners from around the Vertical Retainer.

To roll up the Rear Window, remove the Tailgate Bar and open the zippers on each side of the window to the top. Start at the bottom and roll the window to the inside. Avoid wrinkles in the fabric and window. Secure it in place with the elastic garters inside of the top.

26 To Fold the Top Down Collapse Top

Release the front of the top from the windshield. Raise the front of the deck and collapse the rear bows, tucking the two plastic strips above the door openings and the stay pad on the rear bow inside of the bows. Wrap the fabric around the bows, then tuck the rear legs of the top under the bows.

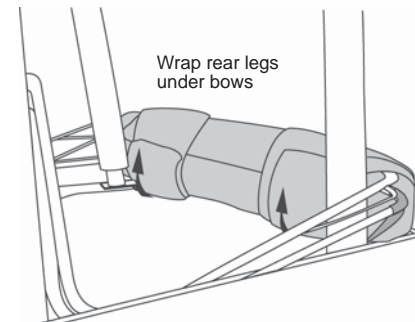
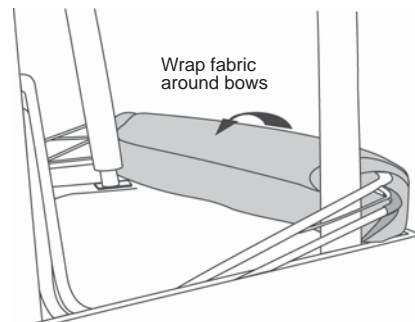
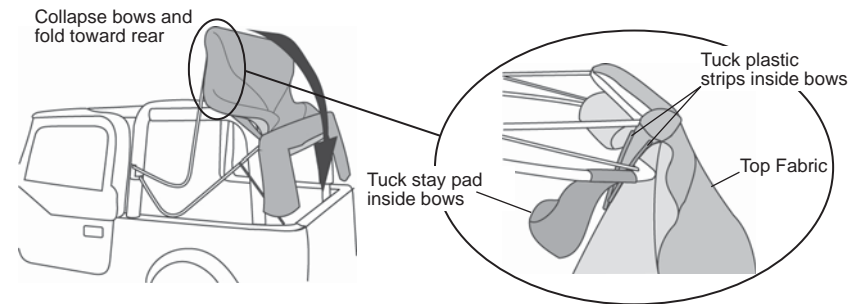

Fabric Replacement Top – Installation Instructions

Care and Maintenance of your New Top

Your top is made of the finest materials available. To keep it looking new and for the maximum possible wear, it will need periodic cleaning and maintenance.

Washing: The fabric should be washed often using soap, warm water and a soft bristle brush. Rinse with clear water to remove all traces of soap.

Zippers: Keeping the zipper cleaned and lubricated with a silicone lubricant will help prevent damage and keep the zippers in a smooth working condition. If a zipper opens behind the slider, the slider may have been spread apart. This problem can usually be repaired by using an ordinary pair of pliers to bring the sides back into parallel. Return slider to the end of the zipper in the normal Open position. Squeeze lightly at first and test the zipper. If the zipper continues to remain open squeeze more firmly with the pliers and try the zipper again. Repeat this procedure until the zipper operates correctly.

Water: In the event of seeping through the seams, 3M Scotchgard® may be applied on the inside of the seams to stop the seepage. Rips in the fabric may be repaired with Bondex® iron on patches. Iron the patches to the Inside of the top, carefully following the Bondex® instructions.

Snaps: Keep snaps cleaned and lubricated with silicone to help prevent snaps from sticking to the studs. If a snap does become stuck to a stud, use a screwdriver and GENTLY pry apart to prevent permanent damage to the snap or the top fabric.

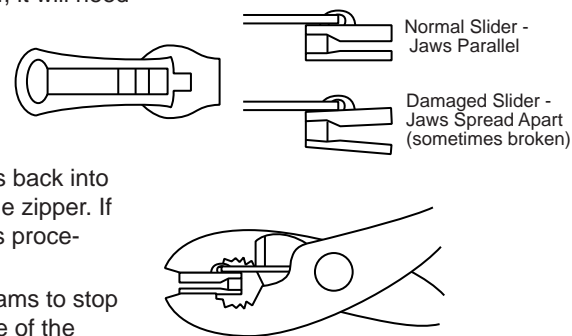



BESTOP WARRANTY SUMMARY

Updated July 2017



WHAT BESTOP WARRANTS

Subject to the terms and conditions of sale, including any terms and conditions set forth by Bestop, Inc. ("Bestop" or "us" or "we") in our then-current terms of sale on our website (collectively, the "Terms"), Bestop represents and warrants that: the covered products listed in the "Covered Products and Warranty Periods" section (a "Product") will substantially be free from defects in materials and workmanship for the specified warranty periods set forth in that section.

THE WARRANTY IS LIMITED AND CONDITIONAL

This warranty applies to the original purchaser of the Product only. The warranty is valid only as long as the original retail purchaser owns the vehicle upon which the Product is installed. The warranty expires should the Product be removed from the original vehicle or if the original vehicle is transferred to another owner. This warranty is not transferable or assignable. The warranty does not apply to Product bought from auction-style or price-bid websites.

THE LIMITED WARRANTY AND STATED REMEDIES ARE SOLE AND EXCLUSIVE AND IN LIEU OF ALL OTHER WARRANTIES AND REMEDIES, AND COMPANY EXPRESSLY DISCLAIMS ALL IMPLIED OR STATUTORY OR OTHER WARRANTIES, INCLUDING WITHOUT LIMITATIONS WARRANTIES OF MERCHANTABILITY, NON-INFRINGEMENT, OR FITNESS FOR A PARTICULAR PURPOSE. IN NO EVENT WILL COMPANY BE LIABLE FOR ANY SPECIAL, INCIDENTAL, CONSEQUENTIAL, PUNITIVE, INDIRECT OR EXEMPLARY DAMAGES OF ANY KIND, INCLUDING LOST PROFITS OR REVENUE, HOWEVER CAUSED, WHETHER FOR BREACH OR REPUDIATION OF CONTRACT, TORT, BREACH OF WARRANTY, NEGLIGENCE, OR OTHERWISE, WHETHER OR NOT COMPANY WAS ADVISED OF THE POSSIBILITY OF SUCH LOSS OR DAMAGES. *Some states do not allow exclusion or limitation, so this may not apply to you. This warranty gives you specific legal rights, and you may have other rights which vary from state to state.*

EXCLUSIONS TO THE WARRANTY

The Limited Warranty excludes, and Bestop is not liable in any way for any warranty claims, damages, or defects related to:

- Misuse, abuse, accidents, vandalism, negligence, fire, or improper installation or modification, or improper or inadequate maintenance;
- Failure to comply with any Product documentation, Bestop instructions, or applicable law or regulations; use in extreme conditions
- Force Majeure including but not limited to, earthquake, hurricane, tornado, flooding, or other disasters natural or man-made, civil unrest, strikes, declared or undeclared war, or lack of performance by, or discontinued product of, supply chain partners whose products, software, operations or management is beyond the control of Bestop;
- Damage resulting in breakage (including without limitation, spontaneous breakage, accidental breakage or breakage by any other means) of a Product or any component part;
- Damage to vinyl windows due to misuse, or cracking due to varying weather conditions.

YOUR SOLE REMEDY

During the applicable warranty period, Bestop shall, at its option, either repair or replace any Product that it confirms, in its discretion, is non-compliant with the warranties herein. Bestop will not pay for labor charges associated with installation or removal of the Product. Should a specific Product be discontinued, Bestop may, at its option, replace the discontinued Product with a current product or like product. If Bestop opts to repair or replace your Product as set forth herein, Bestop shall use reasonable efforts to match any patch or replacement to the color and texture of your existing Product. There is no guarantee however, that Bestop will be able to match the color or texture. If Bestop is not able to match the color or texture, it may provide you with a black or neutral colored patch replacement in its discretion.

Please retain your proof of purchase. Original proof of purchase for the Product must accompany any warranty claim. If you have a warranty claim, first you must email Bestop Customer Service at csbestop@bestop.com for instructions. All claims must be emailed to csbestop@bestop.com within 30 days of discovery of a defective Product, but in no event later than thirty days after the end of the applicable Warranty Period (the "Warranty Notice Period"). Warranty claims made after the Warranty Notice Period are null and void and Bestop shall have no responsibility with respect to such claims.

THIS SECTION SETS FORTH BESTOP'S SOLE OBLIGATION & YOUR SOLE REMEDY WITH RESPECT TO ANY DEFECTS OR OTHER PRODUCT ISSUE. ANY PRODUCTS REPLACED UNDER TERMS OF THIS WARRANTY WILL BE COVERED UNDER TERMS & BALANCE OF THE DURATION OF THE ORIGINAL LIMITED WARRANTY FOR SUCH PRODUCT.

COVERED PRODUCTS AND WARRANTY PERIODS: The warranty time periods are as follows for Products manufactured by Bestop:

BESTOP® LIMITED LIFETIME WARRANTY

Trektop® Pro Twill Fabric Top	Sunrider® for Hardtop Twill Fabric Top
Trektop® NX Glide Twill Fabric Top	Replace-a-Top™ Twill Fabric Top
Trektop® NX Twill Fabric Top	Supertop® NX Twill Fabric Top
EZFold™ Soft Tonneau	Floor & Cargo Liners
ZipRail™ Soft Tonneau	Pet Barriers
EZRoll™ Soft Tonneau	

BESTOP® 5-YEAR LIMITED WARRANTY

Trektop® NX Glide™ Top (non-Twill)	Sunrider® for Hardtop (non-Twill)
Replace-a-Top™ Top (non-Twill)	Trektop® NX Top (non-Twill)
Sailcloth Replace-a-Top™	Supertop® NX Top (non-Twill)
TigerTop™ and HalfTop™	Supertop® Classic Soft Top
Sunrider® Complete Soft Top	Supertop® for Truck
EZ Fold Hard Tonneau	

BESTOP® 3-YEAR/100K MILES LIMITED WARRANTY

Powerboard® & Powerboard® NX
Trekstep®, Side Mount
Trekstep®, Rear Mount

BESTOP® 3-YEAR LIMITED WARRANTY

Pavement Ends Sprint Top

BESTOP® 2-YEAR LIMITED WARRANTY

Trektop® Classic Soft Top
RoughRider™ Soft Storage

BESTOP® 1-YEAR LIMITED WARRANTY

All other Bestop® & Pavement Ends™ products not specified above.