



# Duster Deck Cover Installation Instructions

For: Jeep® Wrangler, 1997 - 2002  
with Factory Original Soft Top

Part Number: 90019



**DO NOT INSTALL THIS PRODUCT ON ANY VEHICLE OTHER THAN THOSE LISTED ABOVE.**  
This product is only designed for the vehicles listed above. Failure to install this product on the proper vehicle could cause injury to the vehicle occupants and damage to the product.

#### Installation Time



30 Minutes

#### Skill Level



1 - Easy



## WARNING

This product is designed to enhance the appearance of the vehicle. Do not rely in any way on the components of this product to contain occupants or cargo within the vehicle, or to protect against injury or death in the event of an accident. Never operate vehicle in excess of manufacturer's specifications.

### WEAR SEAT BELTS AT ALL TIMES

Read and follow, precisely, all installation instructions provided when installing this product. Failure to do so could place occupants or cargo of the vehicle in a potentially dangerous situation. After installing or reinstalling, check to make sure it has been properly installed.

## Installation Tips

Before you begin installing this product, read all instructions thoroughly. Below are a few tips to make this installation easier. After completing the installation, keep these instructions for further reference.

### For a smooth fit:

For ease in installation, the Duster should be installed at temperatures above 72° F. Below this temperature, the fabric may contract an inch or more, making it difficult to fit to the vehicle.

It is normal for the fabric to contract and wrinkle when stored in the shipping carton. Within a few days after the installation, the fabric will relax and the wrinkles will disappear.

## Installation

### Parts List

Duster

Qty - 1

**Note:** This product is designed for a "Custom Fit".  
Be patient during the installation, it fits tight!



### Caution

Safety glasses should be worn at all times while installing this product.

### Step One

#### FOLD DOWN TOP

Remove the Rear Quarter Windows and Rear Window from the top. Remove the Tailgate Retainer from the Rear Window. Cover the "glass" in the Rear Quarter Windows and the Rear Window and store them while not in use. Release the front of the top from the windshield. Raise the front of the deck and collapse the rear bows, tucking the two plastic strips above the door openings and the stay pad on the rear bow inside of the bows,

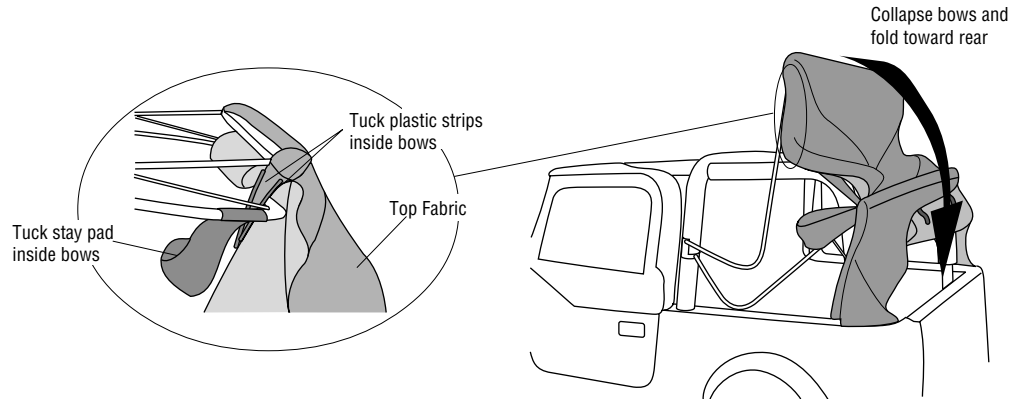

### Step Two

#### WRAP FABRIC AROUND BOWS

Lay the bows down along the rear of the vehicle. Wrap the fold of fabric from the rear of the vehicle up around the bows. Then tuck the rear legs of top under the bows and wrap them around the deck fabric as tight as possible. Tuck the fabric and bows down into the tub as far as possible.

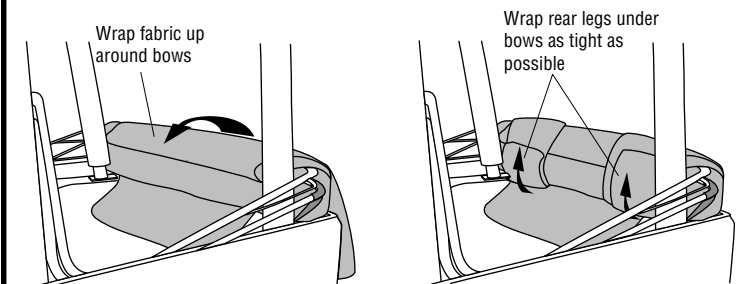

### Step Three

#### INSTALL TAILGATE BAR

Fold down the rear seat. From the back of the vehicle, hold the Duster with the backing side toward you. Slide the tubing into the channel in the Tailgate Retainer and install the retainer into the Tailgate Retainer Mount.

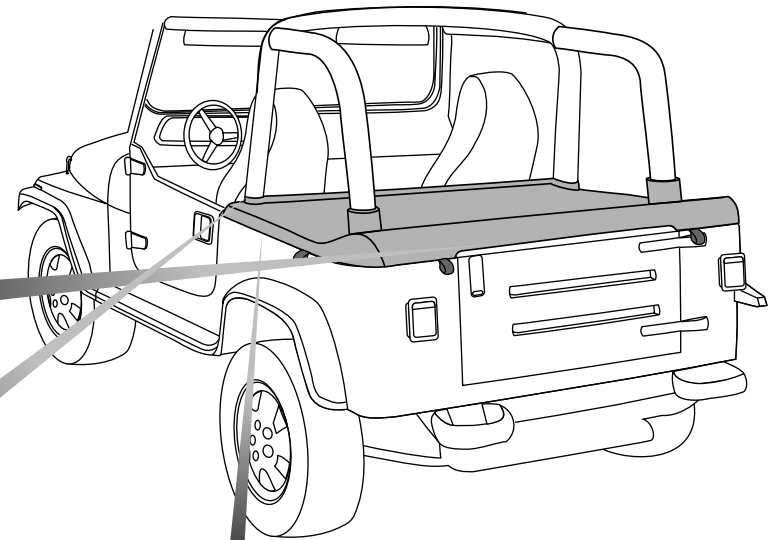
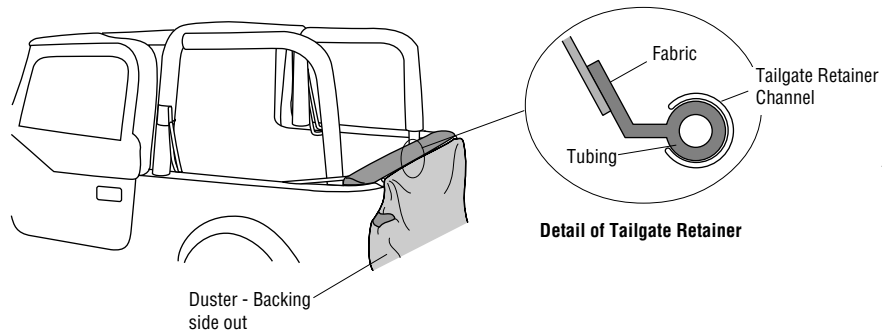

### Step Four

#### SECURE WEB STRAPS

Drape the fabric forward over the rear of the vehicle and locate the web straps, with buckles attached, on the front of the Duster. Wrap the straps around the front sport bars and thread the ends loosely through the buckles. Do not pull the straps tight at this time.

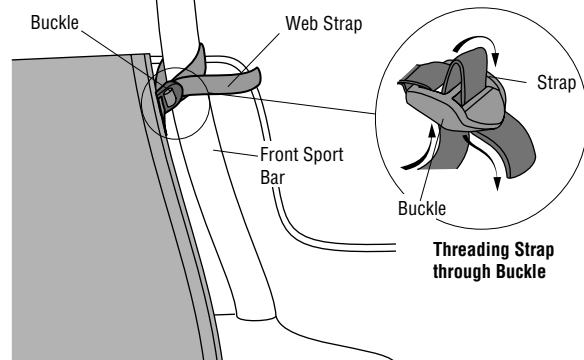

### Step Five

#### SECURE PLASTIC STRIPS

Locate the plastic strip sewn to the Duster along each side of the vehicle. Start at one end on each side and roll the plastic strip into the Side Retainers.

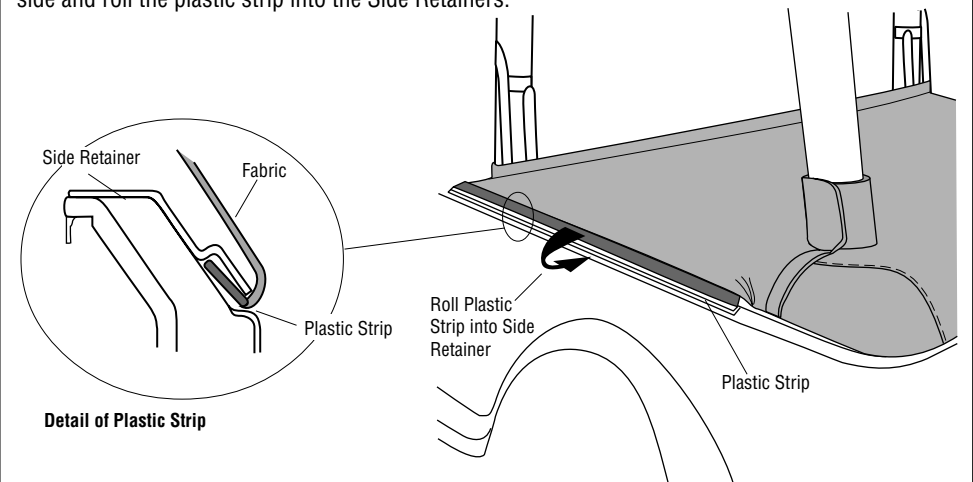

## Step Six

### SECURE REAR CORNERS

Roll the plastic strips, sewn into the rear corners of the Duster into the Corner Retainers. Slide the corner plastic strip toward the front of the vehicle and make sure that the plastic strip fits up into the retainer so that the collar fits properly.

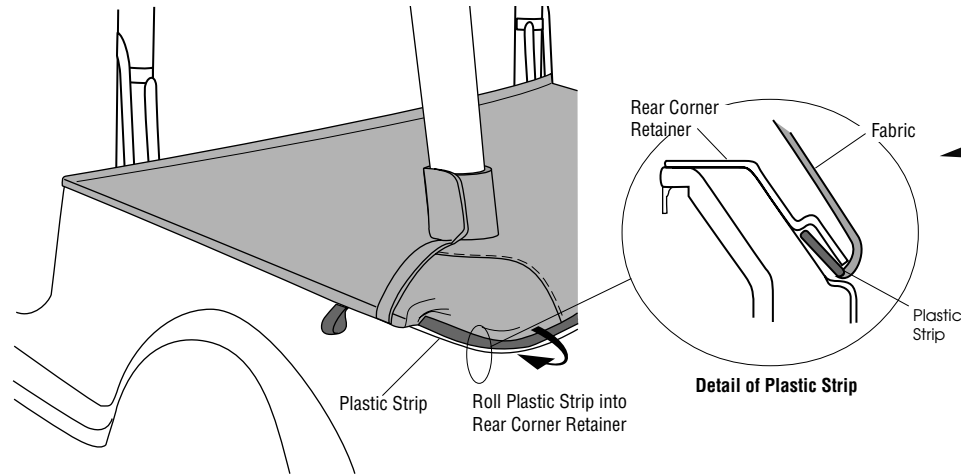

*Note: The Plastic Protector sewn into the fabric must be located over the ends of the Tailgate Bar.*

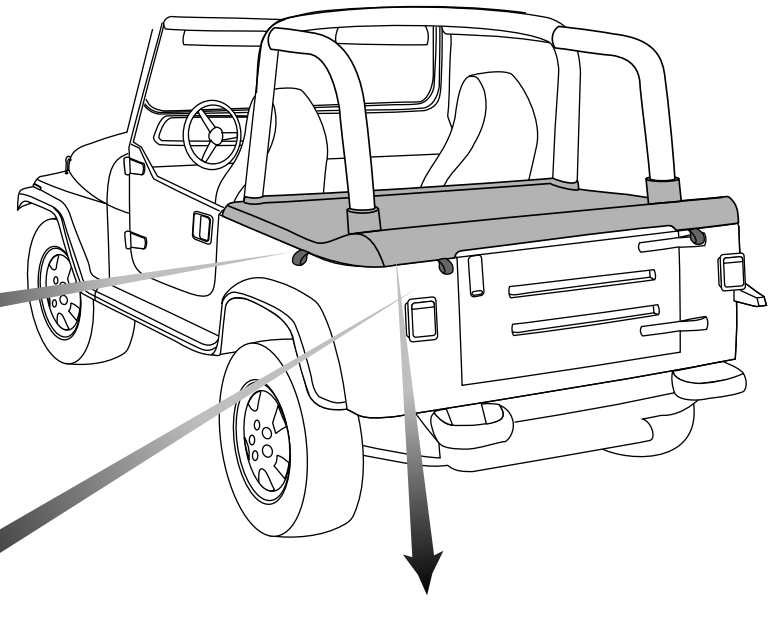

## Step Seven

### SECURE COLLARS

Tuck the seat belt assemblies into the rear sport bar collars and close the rear sport bar collars by pulling firmly on the fabric and fastening the Hook and Loop Strips to each other.

Tighten the straps on the front of the Duster.

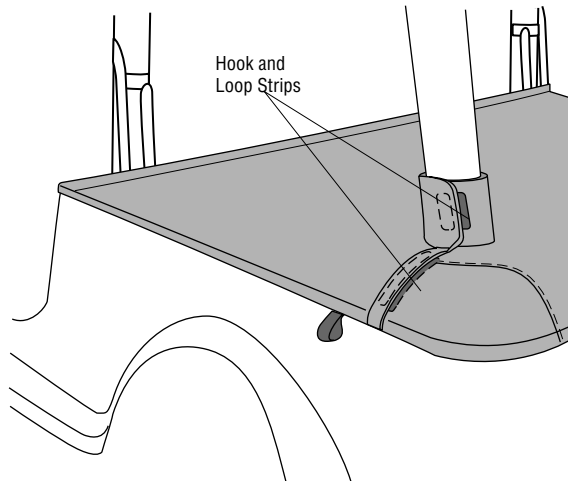

## To Remove Duster

When removing the Duster, use the loops sewn to the fabric to release the plastic strips. Pull gently down, then straight out to release the plastic strip from the retainers.

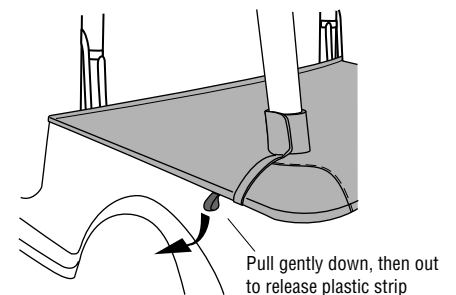

## If You Have a New Windjammer on Your Vehicle Optional Installation

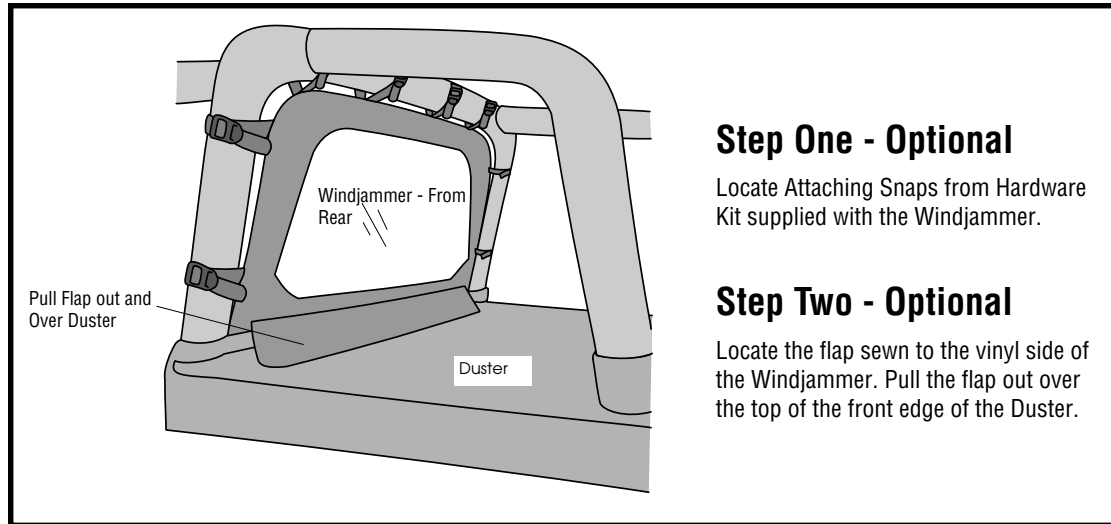

### Step One - Optional

Locate Attaching Snaps from Hardware Kit supplied with the Windjammer.

### Step Two - Optional

Locate the flap sewn to the vinyl side of the Windjammer. Pull the flap out over the top of the front edge of the Duster.

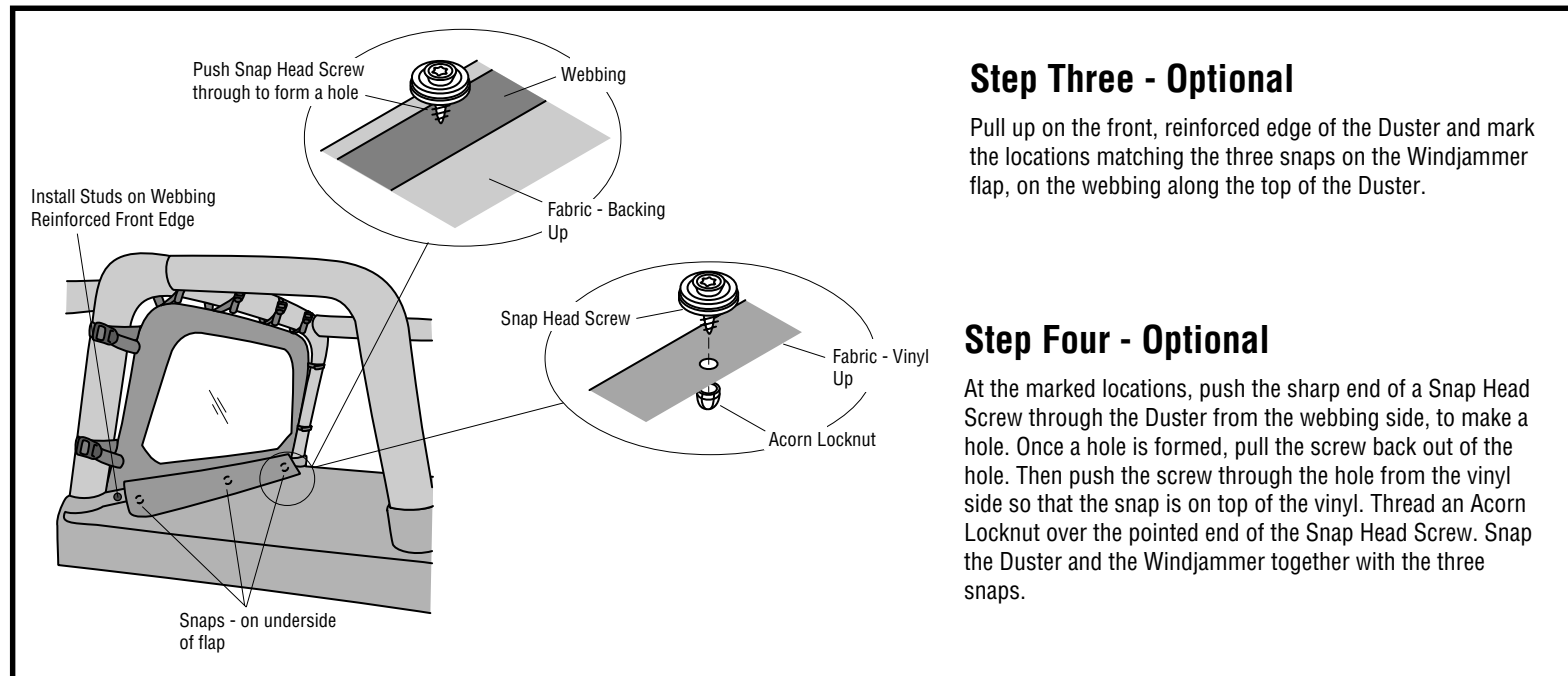

### Step Three - Optional

Pull up on the front, reinforced edge of the Duster and mark the locations matching the three snaps on the Windjammer flap, on the webbing along the top of the Duster.

### Step Four - Optional

At the marked locations, push the sharp end of a Snap Head Screw through the Duster from the webbing side, to make a hole. Once a hole is formed, pull the screw back out of the hole. Then push the screw through the hole from the vinyl side so that the snap is on top of the vinyl. Thread an Acorn Locknut over the pointed end of the Snap Head Screw. Snap the Duster and the Windjammer together with the three snaps.

## ***Care and Maintenance of your New Duster***

Your Duster is made of the finest materials available. To keep it looking new and for the maximum possible wear, it will need periodic cleaning and maintenance.

**Washing:** The fabric should be washed often using soap, warm water and a soft bristle brush. Rinse with clear water to remove all traces of soap.

**Water:** Seeping through at the seams may be stopped by applying 3-M Scotchgard® on the inside of the seams. Rips in the fabric may be repaired with Bondex® iron on patches. Iron the patches to the Inside of the top, carefully following the Bondex® instructions.

**Snaps:** Keep snaps cleaned and lubricated with silicone to help prevent snaps from sticking to the studs. If a snap does become stuck to a stud, use a screwdriver and GENTLY pry apart to prevent permanent damage to the snap or the top fabric.

## **LIMITED WARRANTY**

We warrant our product to be free from defects in material and workmanship, for terms specified below, provided there has been normal use and proper maintenance. This warranty applies to the original purchaser only. All remedies under this warranty are limited to the repair or replacement of any item or items found by the factory to be defective within the time period specified.

If you have a warranty claim, first you must call our factory at the number below for instructions. You must retain proof of purchase and submit a copy with any items returned for warranty work. Upon completion of warranty work, if any, we will return the repaired or replaced item or items to you freight prepaid. Damage to our products caused by accidents, fire, vandalism, negligence, misinstallation, misuse, Acts of God, or by defective parts not manufactured by us, is not covered under this warranty.

THE WARRANTY TIME PERIOD IS AS FOLLOWS: ALL "SOFT GOODS" MANUFACTURED BY OUR COMPANY: ONE YEAR FROM DATE OF PURCHASE.

ANY IMPLIED WARRANTIES OF MERCHANTABILITY AND/OR FITNESS FOR A PARTICULAR PURPOSE CREATED HEREBY ARE LIMITED IN DURATION TO THE SAME DURATION AND SCOPE AS THE EXPRESS WRITTEN WARRANTY. OUR COMPANY SHALL NOT BE LIABLE FOR ANY INCIDENTAL OR CONSEQUENTIAL DAMAGE.

Some states do not allow limitations on how long an implied warranty lasts, or the exclusion or limitation of incidental or consequential damages, so the above limitations or exclusions may not apply to you.

This warranty gives you specific legal rights, and you may also have other rights which vary from state to state.

For further information, please contact:

Bestop Inc.  
Customer Service  
(800) 845-3567

