

BX1671

2003 Cadillac DTS

Installation Instructions

Parts List

Ref. No.	Qty.	Part #	Description
1	1	61-6339	Weldment, Baseplate, BX1671
2	8	61-3799	1/2-13 Nut Plate with 10" Wire
3	8	201-0153	1/2-13 x 2 1/2" Hex Bolt, Grd. 5, ZP
4	8	203-0012	1/2" Lock Washer, ZP
5	1	101-6845	Electrical Bracket
6	2	201-0050	1/4-20 x 3/4" Hex Bolt, Grd. 5, ZP
7	4	203-0001	1/4" Flat Washer, ZP
8	2	202-0069	1/4-20 Hex Whiz Lock Nut, ZP
9	2	201-0192	#10-32 x 1/2 Slot, Rd. Hd. Screw
10	2	203-0054	#10 Lock Washer
11	2	202-0047	#10-32 Hex Nut
12	2	101-5822	Adapter, 4 Way Connector
13	2	201-0654	#10-16 x 1" Self Drilling Screw, ZP
14	2	62-3468	Attachment, Assembly, SF/SB (R)
	2	226-0049	Baseplate Safety Cable, 36" CL IV (Not Shown)
	2	229-0512	Quicklink, 1/2, ZP (Not Shown)
	2	290-0437	Receiver, Cap Plug (BLK) (Not Shown)

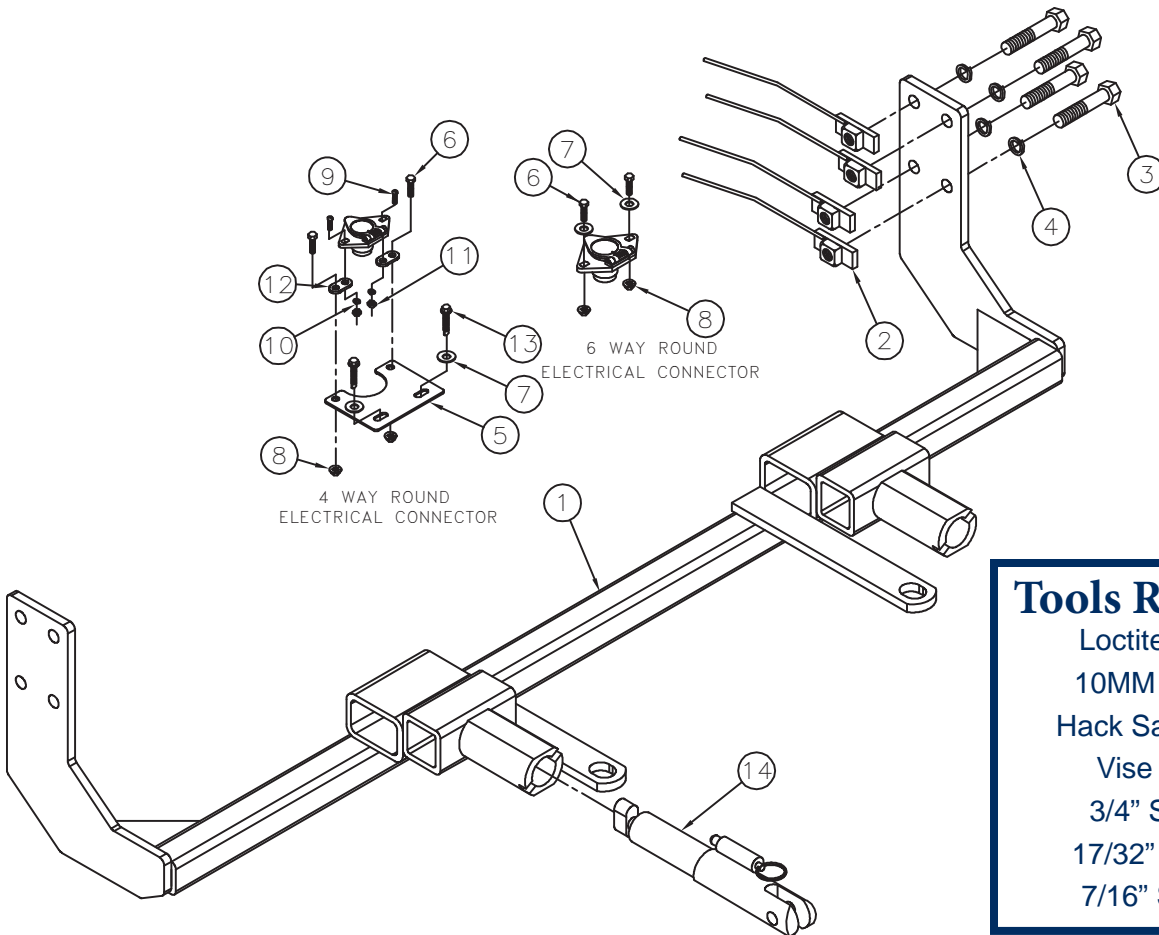

Tools Required

- Loctite® RED
- 10MM Socket
- Hack Saw Blade
- Vise Grips
- 3/4" Socket
- 17/32" Drill Bit
- 7/16" Socket

Important:

Use only genuine factory replacement parts on your baseplate. Do **NOT** substitute homemade or non-typical parts. If a bolt is lost or in need of replacement, for your safety and the preservation of your baseplate, be sure to use a replacement bolt of the same grade (In most cases it will be Grade 5, please reference the parts list above). Replacement parts may be ordered through your nearest Blue Ox® Dealer or Distributor.

BX1671
2003 Cadillac DTS
Installation Instructions

Attachment Tabs:

Due to the design of the removable tabs, the RangeFinderII tow bar can not be used. Adapters, except the BX8833 and BX88151, can not be used with this baseplate.

Installation Notes: The engine compartment covers, fascia and belly pan are removed for installation. Drilling is required. The grille must be trimmed.

The dimensional variations between otherwise identical vehicles can be considerable. While the baseplate was designed for easy installation, it may be necessary to tailor the baseplate slightly to compensate for auto manufacturer's tolerances. These minor adjustments may include filing a hole slightly, bending electrical rods, and/ or bending end plates.

The BX8848 Diode Wiring Kit is recommended for this vehicle.

Installation Instructions:

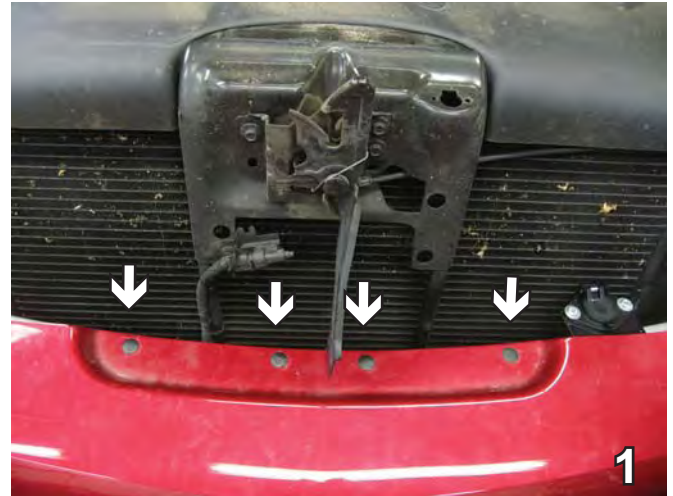

1. Remove four christmas trees from the top edge of fascia, just between the headlights. Set christmas trees aside to be reinstalled later.

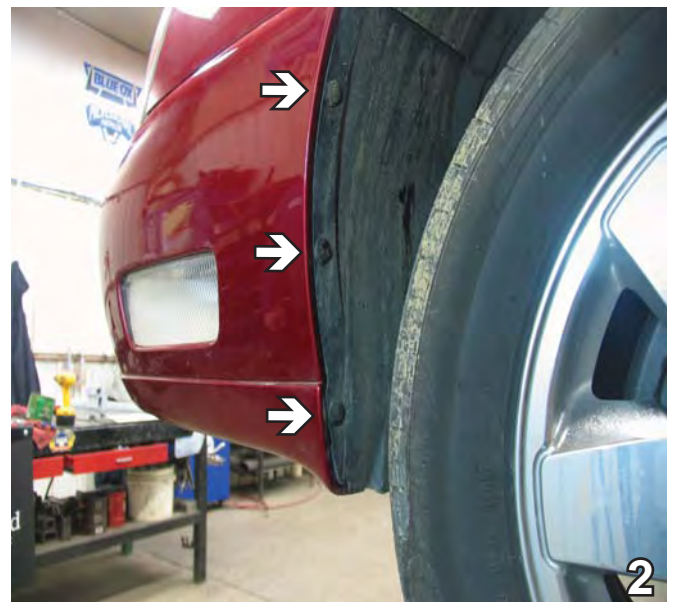

2. Just forward of the front tire, inside the wheel well, remove three pushpins. Do this to both sides of the vehicle. Set pushpins aside to be reinstalled later.

BX1671
2003 Cadillac DTS
Installation Instructions



3. Just forward the front tire on the lower edge of the wheel well, remove two pushpins. Do this to both sides of the vehicle. Set pushpins aside to be reinstalled later.



4. Just forward the front tire, on the bottom side of the fascia, remove two pushpins. Do this to both sides of the vehicle. Set pushpins aside to be reinstalled later.

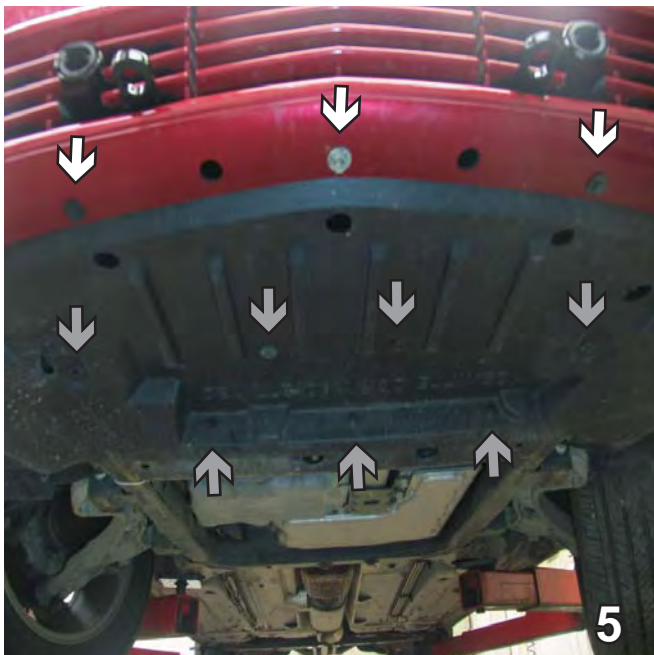

5. Remove three pushpins from the front lower edge of fascia underneath (see white arrows), four pushpins from the center of the belly pan and three christmas trees from the back of the belly pan (see grey arrows). Set pushpins and belly pan aside to be reinstalled later.



6. Underneath fascia on the back edge of the belly pan, remove one pushpin. Do this to both sides of the vehicle. Set aside to be reinstalled later.

BX1671
2003 Cadillac DTS
Installation Instructions



7. Using a 10MM socket, remove one metric bolt from inside the fascia on the corner and loosen (do not remove) two other bolts just forward the first one. Take fascia corner and pull it towards the front of the vehicle, then down and forward again to release it the rest of the way. Disconnect fog and side marker lights. Do this to both sides of the vehicle. Set bolts and fascia aside to be reinstalled later.



8. Using a 10MM socket, remove the metric bolt on the horn bracket. Set bolt and horn bracket aside to be reinstalled later.

BE SURE TO USE LOCTITE® RED ON ALL BOLTS BEFORE TIGHTENING. TIGHTEN ALL BOLTS ACCORDING TO THE TORQUE CHART ON THE FRONT PAGE OF THESE INSTRUCTIONS OR ON PAGE 3 OF THE BASEPLATE TOWING GENERAL INSTRUCTIONS.

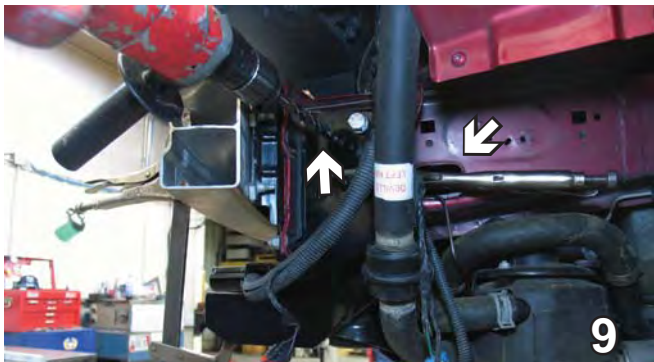

9. Disconnect wiring from area in front of the frame rail. Slide baseplate up so its 1/4" below the top edge of the frame rail and 1/8" away from nut plate built for bumper bracket. Take the vise grips through the hole in the frame and clamp baseplate to frame rail. Then drill all four holes using the baseplate as a template with a 17/32" drill bit. Do this to both sides of the vehicle.

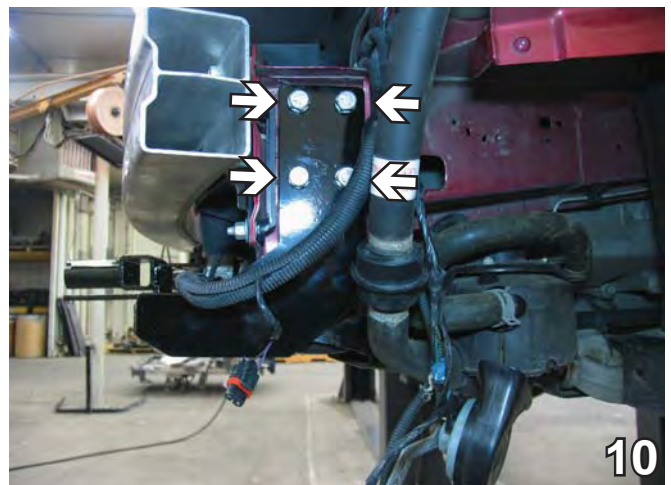

10. Insert 1/2-13 nut plates through the hole in the frame and align to drilled holes. Insert the 1/2-13x2 1/2" hex bolts and 1/2" lock washers and tighten with 3/4" socket. Trim nut plate wires. Do this to both sides of the vehicle.

BX1671
2003 Cadillac DTS
Installation Instructions



11. Hold the fascia up to its original location. Mark and cut the fascia just on the outside edges of the receiver tube. You should only have to cut the two lower ribs on the fascia. The convenience links should come through the lower opening. Do this to both sides of the vehicle.



12. Attach electrical bracket to the top of the metal bumper just inside bumper area on the drivers side, using two #10-16x1" self drilling screws and two 1/4" flat washers. Install electrical connector per parts list diagram.

12. Reinstall horn bracket, belly pan, fascia, pushpins and bolts. The baseplate is now installed.

Be sure that **ALL** electrical connections are plugged in properly and functioning **BEFORE** installing the fascia.

DEALER or INSTALLER:
Be certain the user receives the instruction sheets for their products.

Install the tow bar and safety cables according to the instructions provided in their packages. When demonstrating this to the customer, be sure to include all the contents and packages.

Do **NOT** substitute other devices if the tow bar pins and clips are misplaced.

BX1671
2003 Cadillac DTS
Installation Instructions



Shown without removable tabs installed.

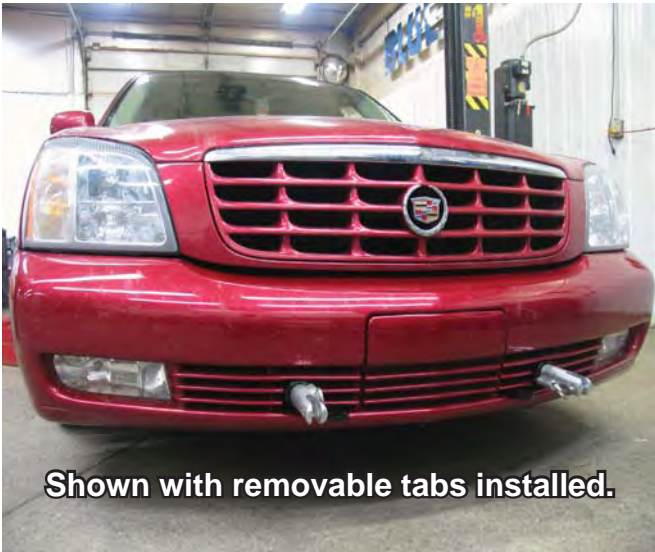

Shown with removable tabs installed.

Customer Service Commitment

Blue Ox® is focused on providing exemplary customer service, as observed in our mission statement and guiding principles. In accordance with this objective, Blue Ox® is proud to provide services such as repairs and general maintenance of Blue Ox® products at over 150 RV Rallies. Look for our Destination America or Blue Ox® Racing service crews at the next rally or race that you attend. If you were not present, you will find an informative, personalized note explaining any services that may have been performed to your Blue Ox® products.

Blue Ox® also offers educational seminars at rallies and through our Park and Resort teams. In addition, Blue Ox® customers visiting our factory may take advantage of the well-equipped Blue Ox® RV park at no charge to you, our valued and appreciated customer.



© 2006 Blue Ox
One Mill Road, Industrial Park
Pender, Nebraska 68047
Phone: (402) 385-3051 • Fax: (402) 385-3360
www.blueox.com
7/8/08