



BX1674

2007-13 Chevy/GMC 1500 Hybrid & New Style Installation Instructions

Serial Number

Attachment Tab Height: 15-1/4"

Attachment Tab Width: 31-1/2"

Please read BOTH these Installation Instructions and the General Instructions prior to installing or operating this equipment.

- Blue Ox® towing products and accessories are intended to be installed by Blue Ox® Dealers who are familiar with our products and have the equipment and knowledge necessary to do "fit work". If needed, Blue Ox® Dealers can be found at www.blueox.com or by contacting our Customer Care Department at (402) 385-3051.
- Many Blue Ox® baseplates are designed to use existing holes and hardware to mount the baseplate to the towed vehicle. Even though bolts are there, do not assume they are adequate for baseplate mounting. Always use the hardware supplied in the hardware kit and existing hardware as specified in the installation instructions.

Bolt Torque Specifications
Torque in Foot-Pounds for Metric Bolts

| Bolt Size | Grade 8.8 | Grade 10.9 |
|-----------|-----------|------------|
| 6MM | 6 | 8 |
| 8MM | 16 | 22 |
| 10MM | 31 | 40 |
| 12MM | 54 | 70 |
| 14MM | 89 | 117 |

Bolt Torque Specifications
Torque in Foot-Pounds for Inch Bolts

| Bolt Size | Grade 5 | Grade 8 |
|-----------|---------|---------|
| 1/4" | 10 | 14 |
| 5/16" | 19 | 29 |
| 3/8" | 33 | 47 |
| 7/16" | 54 | 78 |
| 1/2" | 78 | 119 |
| 5/8" | 154 | 230 |



If the front of your vehicle looks different than this, please contact us at (402)385-3051.

Reference your vehicle owner's manual for manufacturer's towing specifications.

! WARNING

Failure to read and follow these instructions could result in separation of the towed vehicle from the tow bar, causing property damage, loss of towed vehicle, personal injury or death.

BX1674
2007-13 Chevy/GMC 1500 Hybrid & New Style
Installation Instructions

Instruction Notes: Some drilling and trimming of the tow hook shield is required.

Place all components that are removed on a flat, sturdy surface. All items will be reinstalled unless otherwise noted after the baseplate is installed.

The dimensional variations between otherwise identical vehicles can be considerable. While the baseplate was designed for easy installation, it may be necessary to tailor the baseplate slightly to compensate for vehicle manufacturer's tolerances.

The BX8869 Tail Light Wiring Kit is recommended for this vehicle.



Drill a hole according to the tail
light wiring kit instructions.

NOTICE

- Handling of some cosmetic parts when installing this product may require the use of protective covers, rags, specialty tools, etc. to prevent damage.
- When using power drills be aware of the dangers of torque and drill bit length.
- Be sure that **ALL** electrical connections are plugged in properly and functioning before reinstalling the fascia.
- Do not use the towed vehicle for storing luggage, equipment, etc. This may cause you to exceed the towing capacity of the tow bar, baseplate and its accessories.
- Be sure to use Loctite® Red on all bolts before tightening. Tighten all bolts according to the torque chart provided.

BX1674

2007-13 Chevy/GMC 1500 Hybrid & New Style Installation Instructions

Tools Required

Reciprocating Saw
Hacksaw Blade
Torque Wrench
Loctite® RED
17/32" Drill Bit
18MM Socket
3/4" Socket

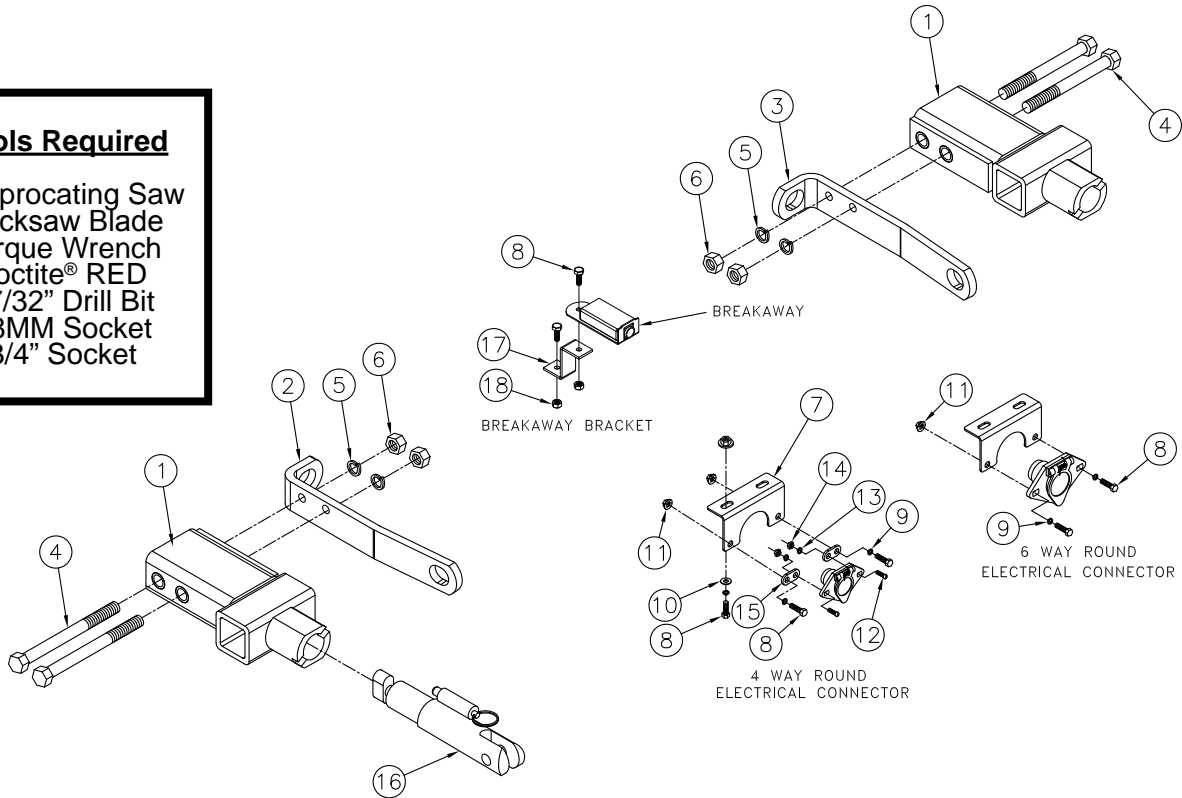

| Item No. | Part No. | Description | Qty. |
|----------|--------------------------|--|------|
| 1..... | 61-6380..... | BX1674 Baseplate..... | 1 |
| 2..... | 102-6797..... | BX1674 Convenience Link, 12", PS..... | 1 |
| 3..... | 102-6798..... | BX1674 Convenience Link, 12", DS..... | 1 |
| 4..... | 201-0786..... | 1/2"-13 x 5" Hex Head Bolt, Grade 5, ZP..... | 4 |
| 5..... | 203-0012..... | 1/2" Lock Washer, ZP..... | 4 |
| 6..... | 202-0094..... | 1/2"-13 Hex Nylon Insert Lock Nut, ZP..... | 4 |
| 7..... | 101-6135..... | 90 Degree Electrical Bracket..... | 1 |
| 8..... | 201-0050..... | 1/4"-20 x 3/4" Hex Head Bolt, Grade 5, ZP..... | 6 |
| 9..... | 203-0008..... | 1/4" Lock Washer, ZP..... | 4 |
| 10..... | 203-0001..... | 1/4" Flat Washer, ZP..... | 2 |
| 11..... | 202-0069..... | 1/4"-20 Hex Flange Whiz Lock Nut, ZP..... | 4 |
| 12..... | 201-0192..... | #10-32 x 1/2" Round Slot Head Screw..... | 2 |
| 13..... | 203-0054..... | #10 Lock Washer..... | 2 |
| 14..... | 202-0047..... | #10-32 Hex Nut..... | 2 |
| 15..... | 101-5822..... | 4 Way Connector Adapter..... | 2 |
| 16..... | 62-3468..... | SF/SB Assembly Attachment..... | 2 |
| 17..... | 102-7056..... | Coolant Bracket Breakaway..... | 1 |
| 18..... | 202-0102..... | 1/4"-20 Hex Nylon Nut, ZP..... | 2 |
| 19..... | 203-0005(not shown)..... | 1/2" Flat Washer..... | 8 |
| 20..... | 226-0046(not shown)..... | Class III Safety Cables..... | 2 |
| 21..... | 229-0512(not shown)..... | 1/2" Quicklink, ZP..... | 2 |
| 22..... | 290-0437(not shown)..... | Black Cap Plug..... | 2 |

Important:

Use only genuine factory replacement parts on your baseplate. Do **NOT** substitute homemade or non-typical parts. If a bolt is lost or in need of replacement, for your safety and the preservation of your baseplate, be sure to use a replacement bolt of the same grade (in most cases it will be Grade 5, please reference the parts list above). Replacement parts may be ordered through your nearest Blue Ox® Dealer or Distributor. Failing to follow and/or altering these installation instructions in either installation or required equipment will void the manufacturer's warranty.

BX1674
2007-13 Chevy/GMC 1500 Hybrid & New Style
Installation Instructions



1. Using a 18MM socket, remove two metric bolts from the inside edge of the frame rail. Do this to both sides of the vehicle. Set the metric bolts and nuts aside to be returned to customer.



2. Using a 18MM socket, remove one nut from the outside edge of the frame rail. Pull the tow hook forward and remove it. Do this to both sides of the vehicle. The factory tow hooks will not be reinstalled. **Note: Please insure that the tow hooks and hardware are returned to customer after baseplate installation.**



3. Using a utility knife, trim the top part of the tow hook shield. Do this to both sides of the vehicle.

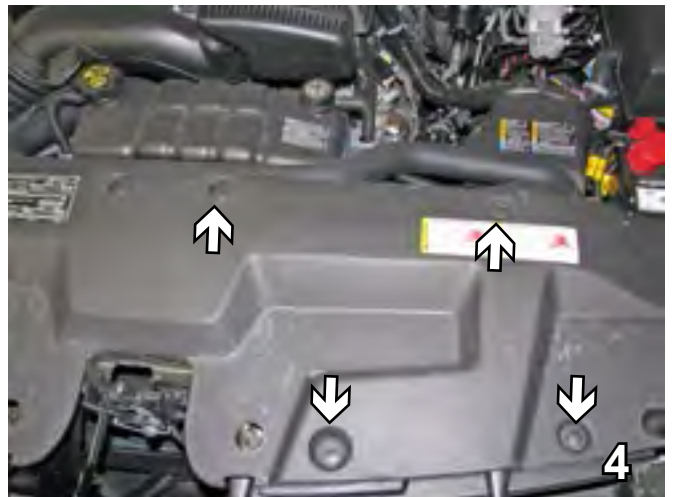

4. Remove four pushpins from the flat plastic piece on top of fascia. Do this to both sides of the vehicle. Set pushpins aside to be reinstalled later.

BX1674
2007-13 Chevy/GMC 1500 Hybrid & New Style
Installation Instructions



5. Using a 10MM socket remove two bolts from the top front edge of the grille. Do this to both sides. Set bolts aside to be reinstalled later.



6. Remove metric bolt on top of frame end, just below plastic removed in Step 4 with 21MM socket. Reinstall bolt with four 1/2" flat washers. Do this to both sides, one side at a time.
Note: On some 2012 models the nut on underside may need to be cut off for baseplate clearance.



7. Remove two push pins from the opening in the grille (7A). They will be replaced with bolts and brackets (7B). Install the breakaway bracket on the passenger side with 1/4"-20 x 3/4" hex bolt and 1/4"-20 hex nut. Attach the breakaway to the bracket also with 1/4"-20 x 3/4" hex bolt and 1/4"-20 hex nut.



8. Slide the baseplate into frame end to align with the front tow hook hole on the outside of the frame rail. Insert straight portion of the convenience link through tow hook opening and align with the existing holes of the frame rail. Insert a 1/2"-13 x 5" hex bolt, 1/2" lock washer and 1/2"-13 hex nylon lock nut into the front hole and tighten down. Do this to both sides of the vehicle.

BX1674
2007-13 Chevy/GMC 1500 Hybrid & New Style
Installation Instructions



9. Using the existing back hole and the baseplate as a template, drill through to the other side of the frame wall with a 17/32" drill bit. Insert a 1/2"-13 x 5" hex bolt, 1/2" lock washer and 1/2"-13 hex nylon lock nut into the back hole and tighten down. Do this to both sides of the vehicle.



10. Attach the permanent baseplate safety cables to the provided convenience link on the baseplate. The photo above shows the recommended installation of the cables to frame of vehicle. Additional options may interfere with suggested mounting; in this case secure the cables to a solid piece of the frame as described in the instructions included with the permanent baseplate safety cables. Be sure the safety cables do not rub against any hoses or moving parts. Do this to both sides of the vehicle.

11. Dealer or installer be certain the user receives the instruction sheet.

Install the tow bar and safety cables according to the instructions provided in their packages. When demonstrating this to the customer, be sure to include all the contents and packages.

Do **NOT** substitute other devices if the tow bar pins and clips are misplaced.

If the baseplate is in an accident, it must be replaced. DO NOT use it again! An accident can cause unseen damage and using it again could result in more damage or serious injury. DO NOT use the baseplate if it is damaged or missing parts.

BX1674
2007-13 Chevy/GMC 1500 Hybrid & New Style
Installation Instructions



2007 - shown without removable tabs installed



2007 - shown with removable tabs installed



2009 - shown without removable tabs installed



2009 - shown with removable tabs installed



2011 - shown without removable tabs installed



2011 - shown with removable tabs installed

BX1674
2007-13 Chevy/GMC 1500 Hybrid & New Style
Installation Instructions

CUSTOMER SERVICE COMMITMENT

Blue Ox® is committed to providing you with exceptional customer care throughout your lifetime with our products. Our team is here to assist you with any questions you may have regarding the performance of your product. Simply call (402) 385-3051 and you can speak with our customer care team.

Additionally, please visit our website to see which rallies our Destination America team will be attending. For a nominal fee, our service technician will service your towing system to ensure it's in proper working condition. Also, as a commitment to our customers, should you visit our factory, you can stay at our full service Blue Ox® campground at no charge along with enjoying a factory tour.

Again, thank you for being our customer and for the confidence you have shown in the performance of our products. It is because of customers like you we enjoy the success we have today.

© 2012 Blue Ox
One Mill Road, Industrial Park
Pender, Nebraska 68047
Phone: (402) 385-3051
Fax: (402) 385-3360
www.blueox.com