



Baseplate Installation Instructions

BX1847 2011 Nissan Juke (No Foglights) Installation Instructions

Serial Number

Please read BOTH these Installation Instructions and the General Towing Instructions before attempting to install or operate this equipment.

- Blue Ox® towing products and accessories are intended to be installed by Blue Ox® Dealers who are familiar with our products and have the equipment and knowledge to do “fit work”. When necessary, Blue Ox® Dealers can be found at www.blueox.com or by contacting our Customer Care Department at (402) 385-3051.
- Many Blue Ox® baseplates are designed to use existing holes and hardware to mount the baseplate to the towed vehicle. Even though bolts are there, do not assume they are adequate for baseplate mounting. Always use hardware supplied in the hardware kit or existing hardware specified in the Baseplate Installation Instructions.

Attachment Tab Height: 16 1/2”

Attachment Tab Width: 19”

Bolt Torque Specifications
Torque in Foot-Pounds for Metric Bolts

Bolt Size	Grade 8.8	Grade 10.9
6MM	6	8
8MM	16	22
10MM	31	40
12MM	54	70
14MM	89	117

Confirm the towability and pre-towing procedures for your vehicle with the owner’s manual or contact the vehicle’s manufacturer for specific towing procedures.

Bolt Torque Specifications
Torque in Foot-Pounds for Inch Bolts

Bolt Size	Grade 5	Grade 8
1/4”	10	14
5/16”	19	29
3/8”	33	47
7/16”	54	78
1/2”	78	119
5/8”	154	230



If the front of your vehicle looks different than this, call us at (402) 385-3051.

! WARNING

Failure to read and follow these instructions could result in separation of the towed vehicle from the tow bar, causing property damage, loss of towed vehicle, personal injury or death.

BX1847

2011 Nissan Juke (No Foglights)

Installation Instructions

Parts List

Ref. No.	Qty.	Part #	Description
1	1	61-6872	WLDM'T, BP, BX1847
2	1	61-6873	WLDM'T, PS, BX1847
3	1	201-0443	3/8-16 X 1 HEX BOLT GRD.5, ZP
4	2	201-0368	3/8-16 X 1 1/4 HEX HEAD BOLT,GRD. 5
5	6	201-0440	3/8-16 X 1 1/2 HEX BOLT, GRD.5, ZP
6	2	201-0011	1/2-13 X 1 1/4 HEX BOLT GRD.5, ZP
7	8	203-0010	3/8 LOCK WASHER, ZP
8	5	203-0003	3/8 FLAT WASHER, ZP
9	2	203-0012	1/2 LOCK WASHER, ZP
10	6	202-0090	3/8-16 HEX NYL. INS. LOCK NUT, ZP
11	2	61-5208	WLD, NUT PLT, 1/4X1X1, 3/8"/14" WIRE
12	2	202-0094	1/2-13 HEX NYL. INS. LOCK NUT, ZP
13	2		Existing Metric Bolt
14	3	201-0655	6MM-1.0 X 30MM HEX BOLT, GRD8.8,ZP
15	3	203-0161	6MM, LOCK WASHER, ZP
16	3	203-0001	1/4 FLAT WASHER, ZP
17	2	201-0553	1/4-20 X 1/2 HX.WSHD.TYPE F TCS, ZP
18	2	201-0192	10-32 X 1/2 SLOT, RD. HD. SCREW
19	2	203-0054	#10 LOCK WASHER
20	2	202-0047	#10-32 HEX NUT
21	2	101-5822	ADAPTER, 4 WAY CONNECTOR
22	1	102-7186	BREAKAWAY BRKT
23	1	201-0654	#10-16 X 1 SELF DRILLING SCREW
24	1	201-0050	1/4-20 X 3/4 HEX BOLT GRD.5, ZP
25	1	202-0102	1/4-20 HEX NYL NUT, ZP
26	2	62-3468	ATT TAB ASSY, REM, SF/SB, 1 HOLE
	4	290-0275	CABLE TIE, 8 INCH NYLON (Not Shown)
	2	290-0437	RECEIVER, CAP PLUG (BLK) (Not Shown)
	2	229-0359	QUICKLINK, 3/8, ZP (Not Shown)
	2	226-0046	BASEPLATE SAFETY CABLE, 36" CL III (Not Shown)

Tools Required

10MM Socket
 17MM Socket
 9/16" Socket/Wrench
 3/4" Socket/Wrench
 Large Vise Grip
 Reciprocating Saw
 Flat Screw Driver
 Utility Knife
 Torque Wrench
 Tape Measure
 Drill
 13/32" Drill Bit
 Loctite® RED

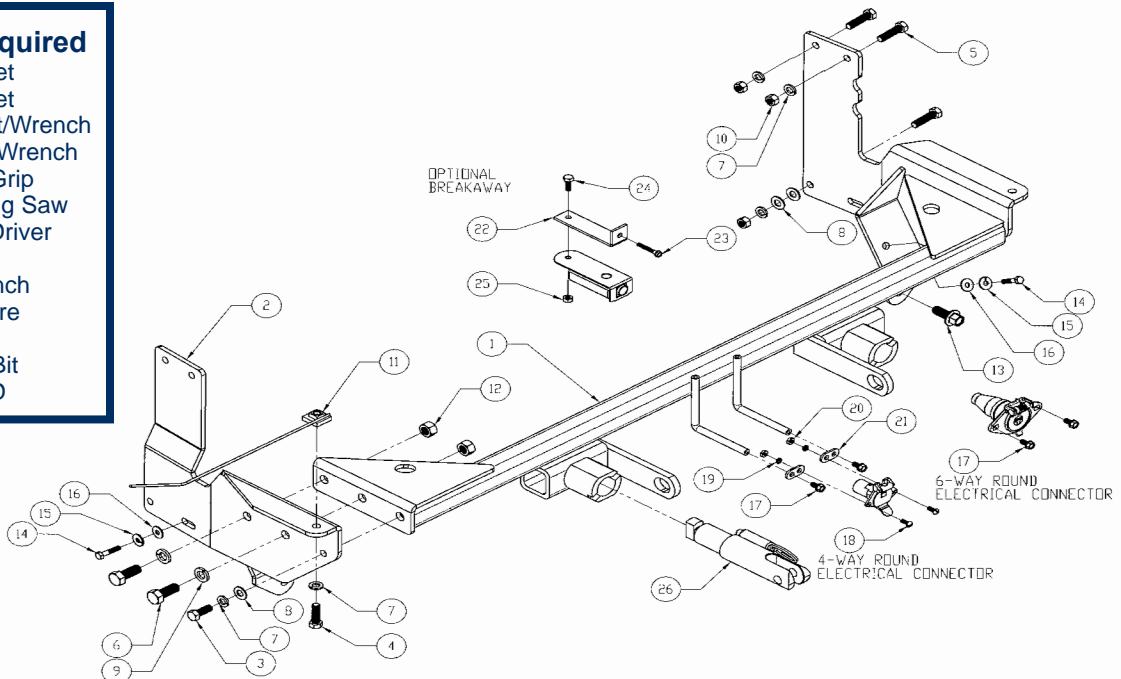

Important:

Use only genuine factory replacement parts on your baseplate. Do NOT substitute homemade or non-typical parts. If a bolt is lost or in need of replacement, for your safety and the preservation of your baseplate, be sure to use a replacement bolt of the same grade (In most cases it will be Grade 5, please reference the parts list above). Replacement parts may be ordered through your nearest Blue Ox® Dealer or Distributor. Failing to follow and/or altering these installation instructions in either installation or required equipment will void the manufacturer's warranty.

BX1847

2011 Nissan Juke (No Foglights)

Installation Instructions

Attachment Tabs: Due to the design of the removable tabs, the RangeFinder II, Acclaim and Ambassador tow bars can not be used. Adapters, except the BX8833 and BX88151, can not be used with this baseplate.

Installation Notes: The fender flares, fascia, washer reservoir, air temperature sensor, air baffle and styrofoam bumper are removed for installation. Trimming of the air dams and frame rail webbing is required. Drilling is required.

The dimensional variations between otherwise identical vehicles can be considerable. While the baseplate was designed for easy installation, it may be necessary to tailor the baseplate slightly to compensate for auto manufacturer's tolerances. These minor adjustments may include filing a hole slightly, bending electrical rods or bending end plates.

The BX8869 Bulb and Socket Wiring Kit is recommended for this vehicle.

Handling of some cosmetic parts when installing this product may require the use of protective covers, rags, specialty tools, etc. to prevent damage.



Possible location for the Bulb and Socket Wiring Kit (BX8869).

Installation Instructions:

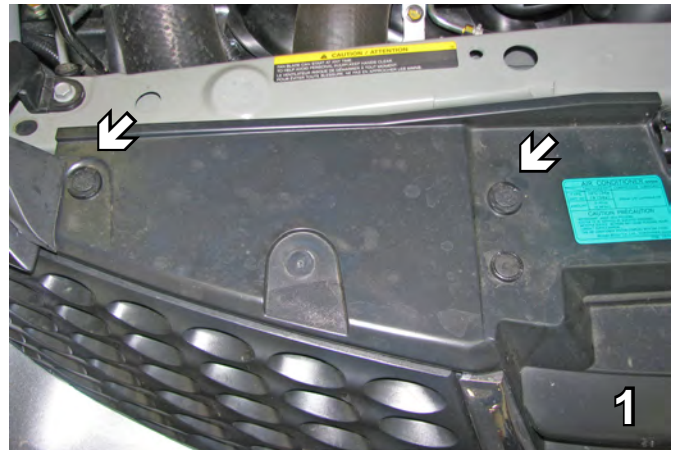

1. Remove two pushpins from the top of the fascia. Do this on both sides of the vehicle. Set pushpins aside to be reinstalled later.



2. Remove two pushpins from each wheel well. Do this on both sides of the vehicle. Set pushpins aside to be reinstalled later.

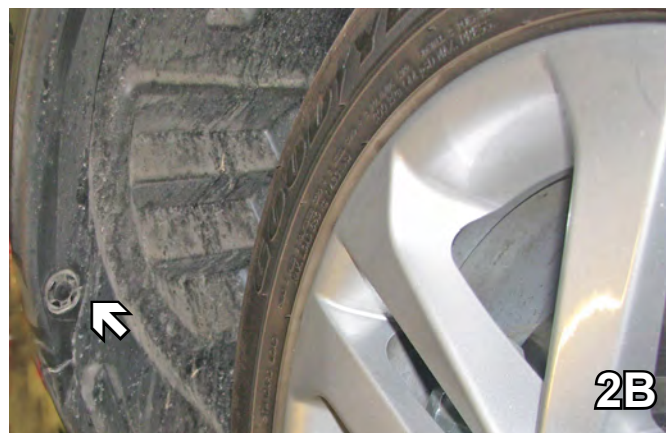

BX1847

2011 Nissan Juke (No Foglights) Installation Instructions



3. Remove the fender flares by pulling out and using a flat screw driver to help release the four tabs from the inside of the fascia. Do this on both sides of the vehicle. Flares to be reinstalled later.
4. Using a 10MM socket, remove the bolt from behind the fender flare. Do this to both sides of the vehicle. Set bolts aside to be reinstalled later.

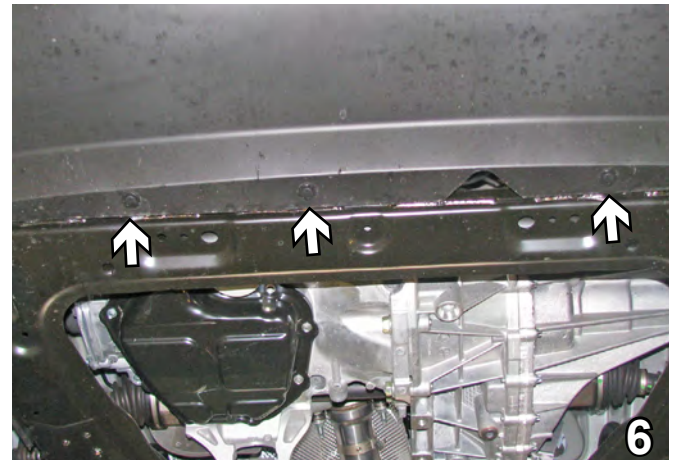

5. Using a 10MM socket, remove two bolts from the bottom of the fascia. Do this to both sides of the vehicle. Set bolts aside to be reinstalled later.
6. Remove three pushpins from the bottom center of the fascia. Pull fascia corners out to the side and forward to remove. Set fascia and pushpins aside carefully to be reinstalled later.

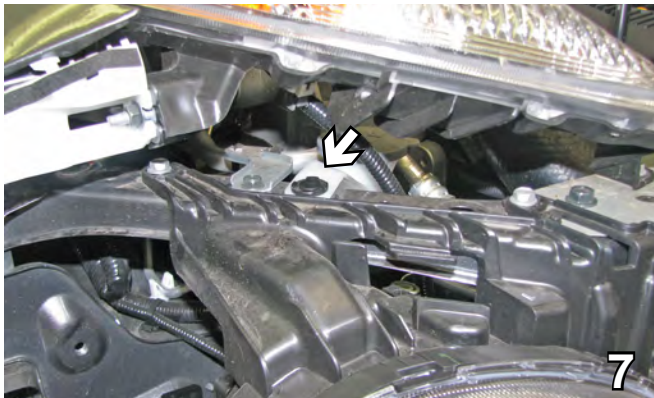

7. Remove one pushpin from the top of the washer reservoir between the passenger side headlight and the blinker. Set pushpin aside to be reinstalled later.

BX1847

2011 Nissan Juke (No Foglights) Installation Instructions

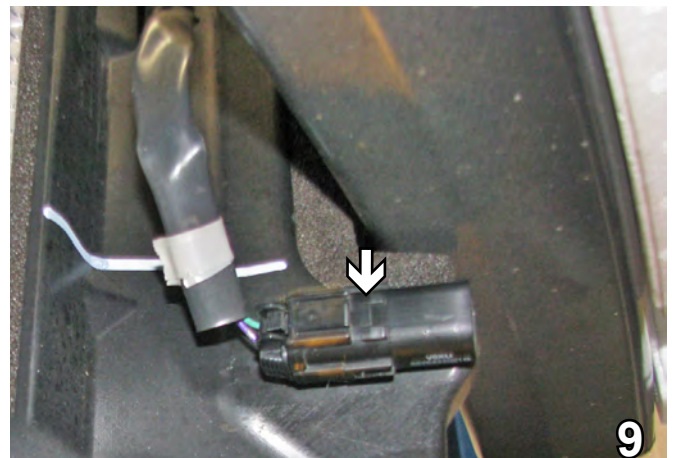
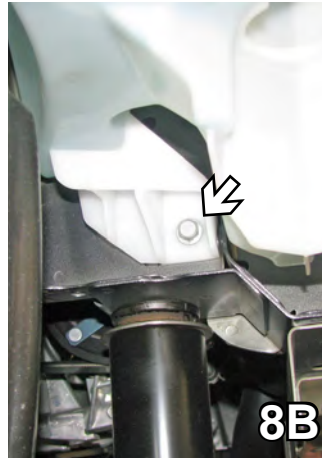
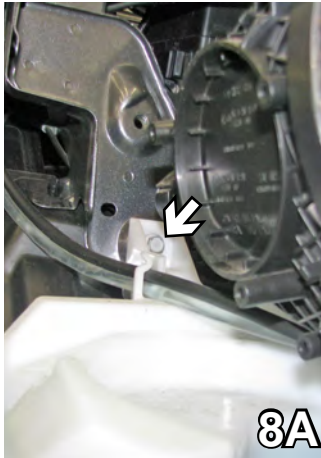

8. On the passenger's side, disconnect electrical connection from the washer reservoir. Using a 10MM socket, remove one metric bolt each from the reservoir's upper and lower brackets. Disconnect and plug the reservoir. Set the bolts and reservoir aside to be reinstalled later.
9. On the drivers side, remove air temperature sensor. Set the sensor aside to be relocated later.

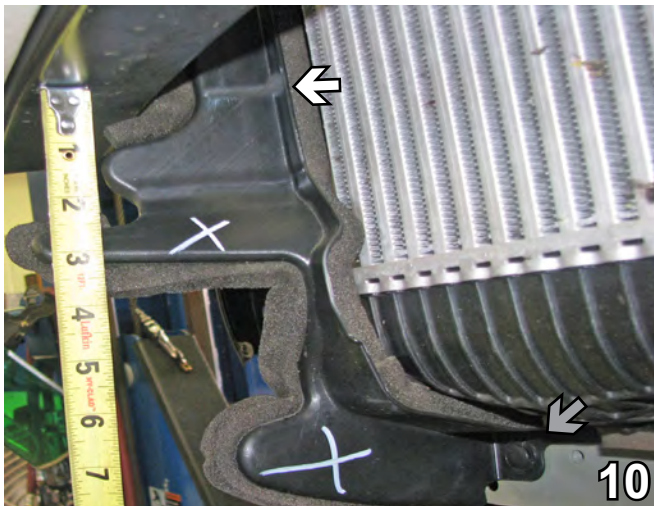

10. Cut with the utility knife the plastic air dam flush with the bottom of the bumper (white arrow). Remove the air dams from each side by removing the push pin from the bottom of each air dam (grey arrow). They will not be reinstalled.
11. Remove the air baffle by removing the push pin from under the headlight. Set the pin aside to be reinstalled later.



12. Using a 10MM socket, remove the bolt from the air baffle underneath the headlight. Set the baffle and bolt aside to be reinstalled later.

BX1847

2011 Nissan Juke (No Foglights) Installation Instructions

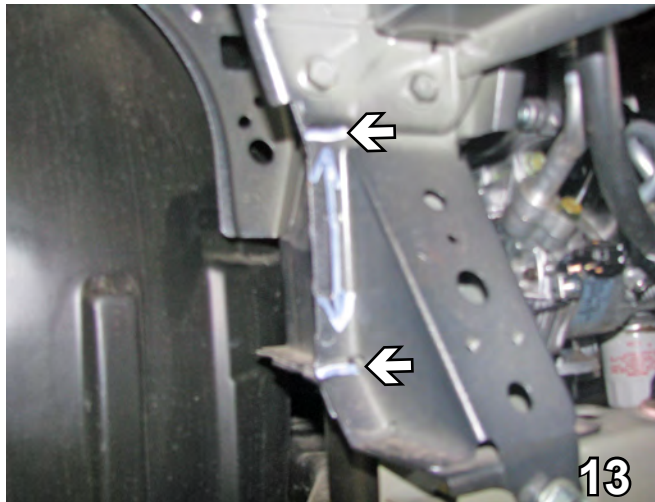

13. Using the reciprocating saw, cut two notches in the lower portion of webbing to the frame rail. Bend this section toward the front of the vehicle. Do this to both sides of the vehicle.

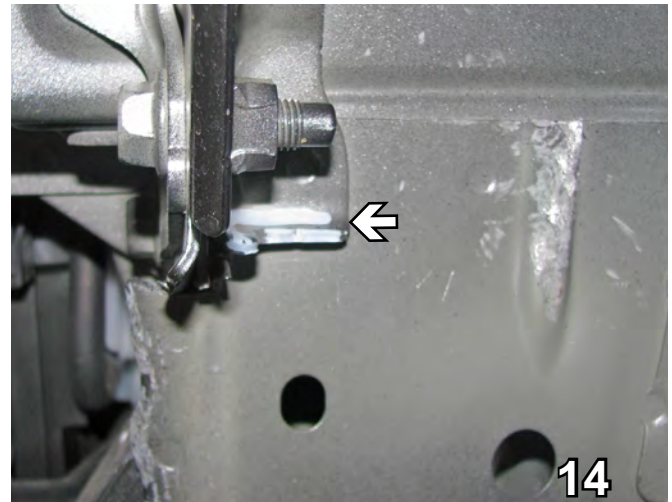

14. On the drivers side only, cut the lip under the bolt on the frame webbing with a reciprocating saw.

When using power drills be aware of the dangers of torque and drill bit length.

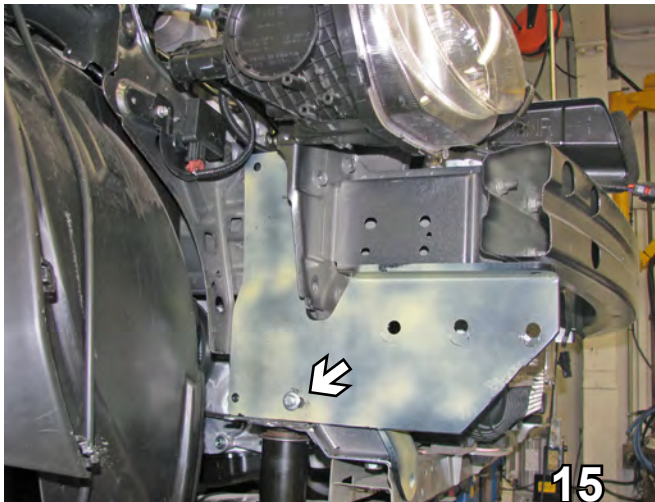

15. Slide the end plate on the passenger side to align the bottom center hole with existing hole in frame rail. It will be a tight fit and may need to be tapped in place. Hand tighten a 6MM-1.0 x 30MM hex bolt with a 1/4" flat washer in the bottom center hole.



16. Attach the 3/8" quick link to the drivers side baseplate before lifting it up to the vehicle. Be sure the baseplate is flush in the back and clamp with a large vise grip.

BX1847

2011 Nissan Juke (No Foglights) Installation Instructions

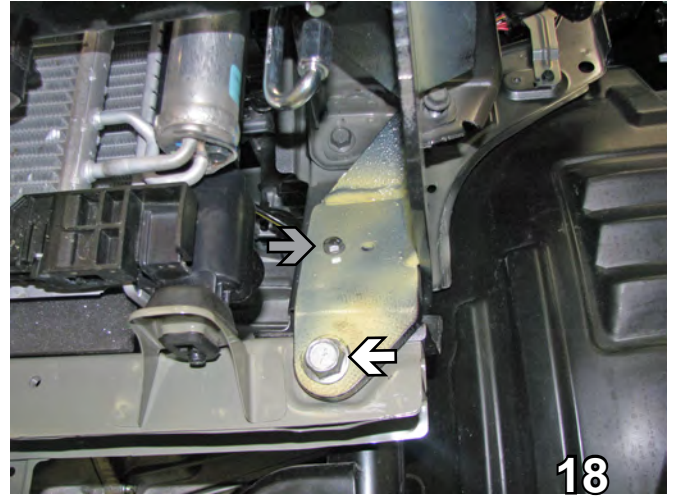
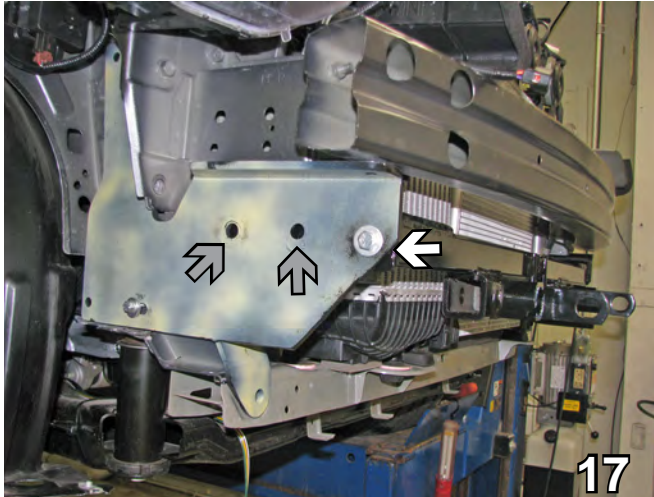

17. Fasten the cross member to the passenger end plate by installing a 3/8-16 x 1" hex bolt with 3/8" lock washer and 3/8" flat washer in the outside hole while aligning the back two with the cross member (grey arrows). Be sure to use Loctite Red on all bolts.
18. Reinstall the existing bolts in the lower holes in the lower bolt location (white arrow). Install 6MM-1.0 x 30MM hex bolt with 6MM lock washer and 1/4" flat washer (grey arrow). Be sure to use Loctite Red on all bolts. Do this on both sides.

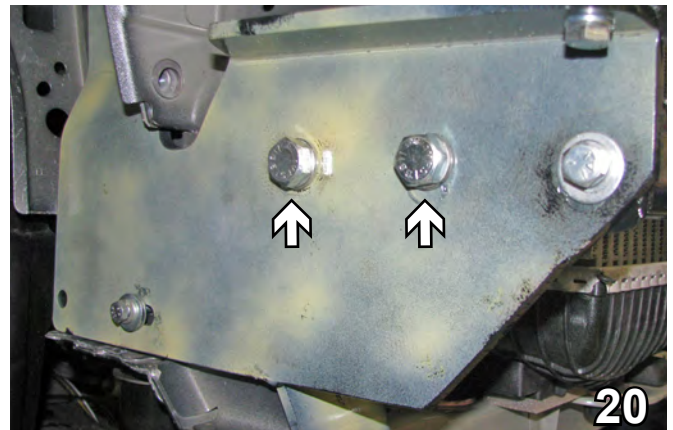
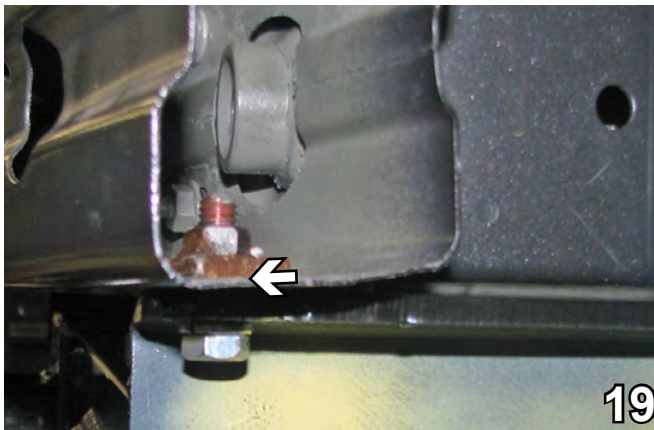

19. Using the baseplate as a template, with a 13/32" drill bit, drill up into the bumper. Insert a 3/8-16 x 1 1/4" hex bolt with 3/8" lock washer and 3/8-16 nut plate inside the bumper. Be sure to use Loctite Red on all the bolts. Do this on both sides of the vehicle.
20. In the remaining top middle holes on the passenger side, insert 1/2-13 x 1 1/4" hex bolts with a 1/2" lock washers and 1/2-13 hex nuts. Be sure to use Loctite Red on all bolts.

BE SURE TO USE LOCTITE® RED ON ALL BOLTS BEFORE TIGHTENING. TIGHTEN ALL BOLTS ACCORDING TO THE TORQUE CHART ON THE FRONT PAGE OF THESE INSTRUCTIONS OR ON PAGE 3 OF THE BASEPLATE TOWING GENERAL INSTRUCTIONS.

BX1847

2011 Nissan Juke (No Foglights)

Installation Instructions

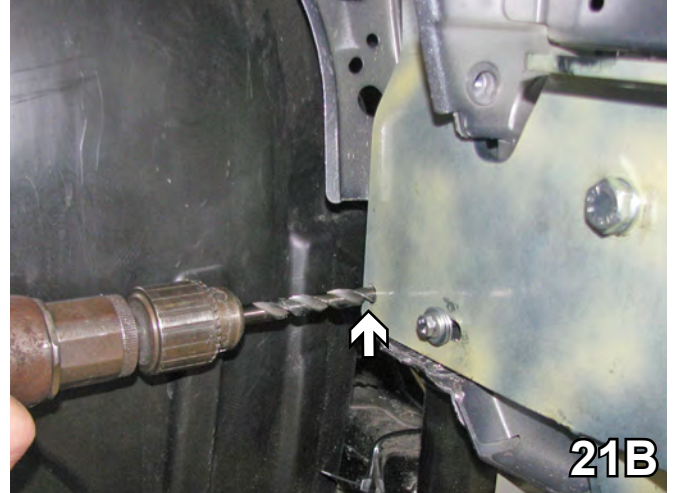
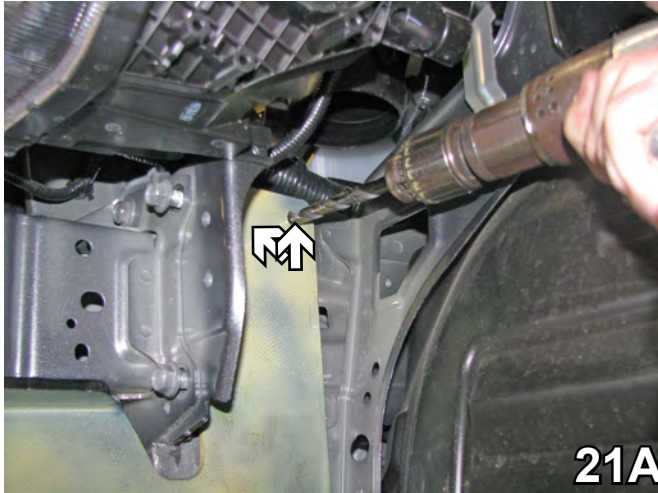

21. Using the baseplate as a template with a 13/32" drill bit, drill out the two holes on the very top of the baseplate (21A) and the one on the bottom corner (21B). Do this on both sides.

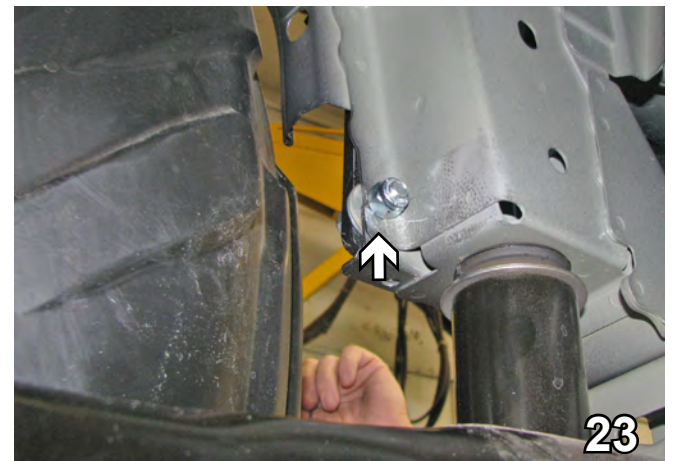
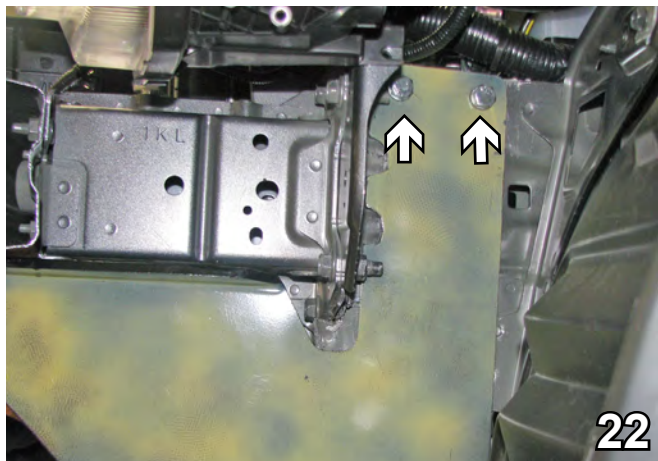

22. In the upper holes, install 3/8-16 x 1 1/2" bolts with 3/8" lock washers, 3/8-16 hex nuts and tighten. There will be a 1/4" gap between the frame and the baseplate. Tighten the baseplate up to the webbing. Be sure to use Loctite Red on all the bolts. Do this on both sides.

23. In the bottom corner holes, install 3/8-16 x 1 1/2" bolts with two 3/8" flat washers in between, 3/8" lock washers, 3/8-16 hex nuts and tighten. Be sure to use Loctite Red on all the bolts. Do this on both sides of the vehicle.

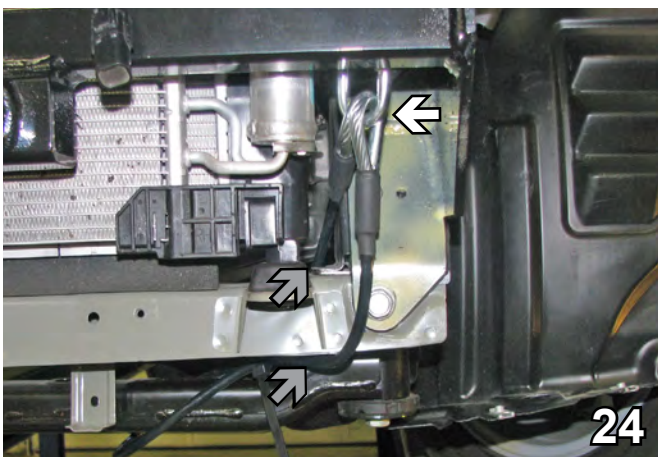

24. Attach the permanent baseplate safety cables to the provided convenience link on the baseplate (white arrow). The photo above shows the recommended installation of the cables to the frame of vehicle (grey arrow). Additional options may interfere with the suggested mounting. In this case, secure the cables to a solid piece of the frame as described in the instructions included with the permanent baseplate safety cables. Be sure the safety cables do not rub against any hoses or moving parts. Do this to both sides of the vehicle.

BX1847
2011 Nissan Juke (No Foglights)
Installation Instructions

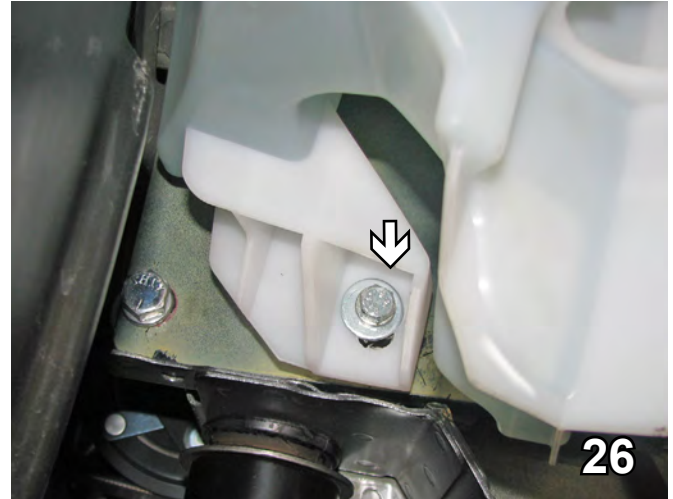
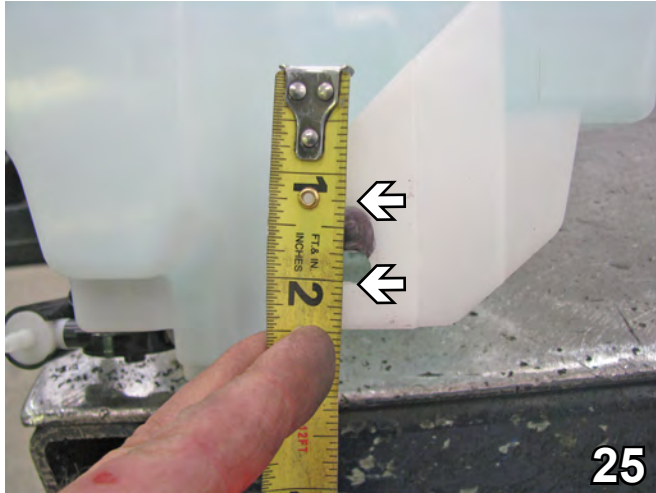

25. Slot the lower bolt hole on the washer reservoir up 3/4" from the bottom of the hole with a 13/32" drill bit.
26. Reinstall the washer reservoir, using the existing bolt on the top. On the bottom, use a 6MM-1.0 x 30MM hex bolt with 6MM lock washer and 1/4" flat washer. Also reattach the pushpin at the top of the washer reservoir under the headlight. Reconnect the electrical plug and the hose.

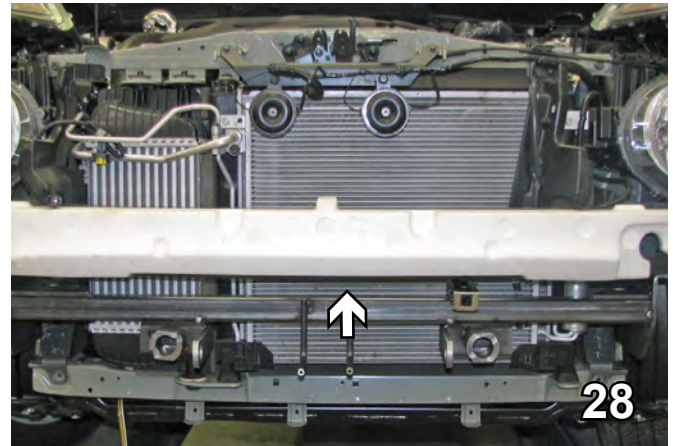

27. On the drivers side of the bumper, relocate the temperature sensor on the cross tube with cable ties.
28. **Optional:** If installing the breakaway bracket, remove the styrofoam from the front of the metal bumper.

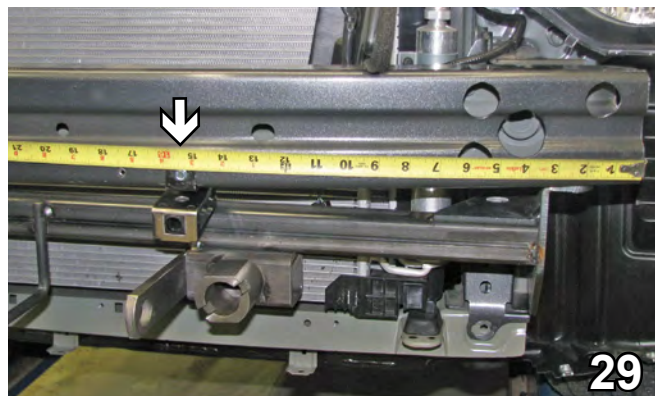

29. Measure 15 1/2" over from the end of the bumper on the drivers side.

BX1847
2011 Nissan Juke (No Foglights)
Installation Instructions

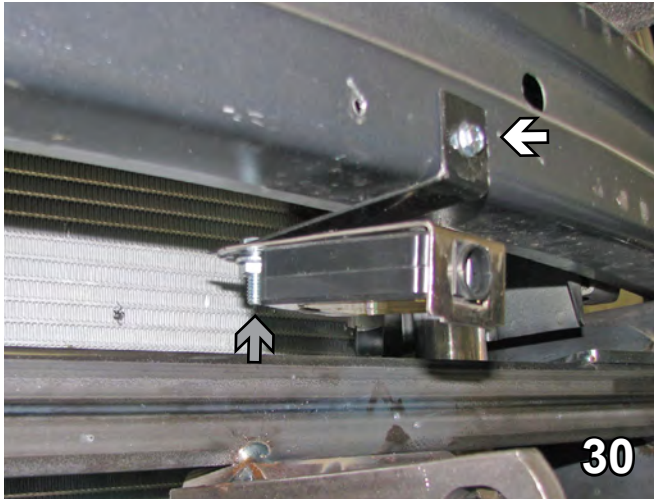

30. Attach the breakaway bracket to the bumper with a 10-16 x 1" self drilling screw (white arrow). Attach the breakaway to the bracket with a 1/4-20 x 3/4" hex bolt and a 1/4-20 hex nut (grey arrow). Reattach the styrofoam.

31. On the passenger side of the fascia, using a utility knife, cut the second section of the fascia out so that it is open.

32. Reinstall the air baffle, fascia, fender flares, pushpins and bolts.

Install the tow bar and safety cables according to the instructions provided in their packages. When demonstrating this to the customer, be sure to include all the contents and packages.

Do **NOT** substitute other devices if the tow bar pins and clips are misplaced.

Be sure that **ALL** electrical connections are plugged in properly and functioning **BEFORE** installing the fascia.

Do not use the towed vehicle for storing luggage, equipment, etc. This may cause you to exceed the towing capacity of the tow bar, baseplate, and its accessories.

DEALER or INSTALLER:
Be certain the user receives the instruction sheets for their products.

BX1847

2011 Nissan Juke (No Foglights)

Installation Instructions



Shown without removable tabs installed.



Shown with removable tabs installed.

CUSTOMER SERVICE COMMITMENT

Blue Ox is committed to providing you with exceptional customer care throughout your lifetime with our products. Our team is here to assist you with any questions you may have regarding the performance of your product. Simply call (402) 385-3051 and you can speak with our customer care team.

Additionally, please visit our website to see which rallies our Destination America team will be attending. For a nominal fee, our service technician will service your towing system to ensure it's in proper working condition. Also, as a commitment to our customers, should you visit our factory you can stay at our full service Blue Ox campground at no charge along with enjoying a factory tour.

Again, thank you for being our customer and for the confidence you have shown in the performance of our products. It is because of customers like you we enjoy the success we have today.

If the baseplate is in an accident, it must be replaced. DO NOT use it again! An accident can cause unseen damage and using it again could result in more damage or serious injury. DO NOT use the baseplate if it is damaged or missing parts.



© 2011 Blue Ox
One Mill Road, Industrial Park
Pender, Nebraska 68047
Phone: (402) 385-3051
Fax: (402) 385-3360
www.blueox.com