



**BX1935**  
**98-00 Chrysler Town & Country**  
**1998-00 Dodge Caravan**  
 (Includes Grand Caravan)  
**1998-00 Plymouth Grand Voyager**  
**Installation Instructions**

**Serial Number**

**Please read BOTH these Installation Instructions and the General Instructions before attempting to install or operate this equipment.**

- Blue Ox® towing products and accessories are intended to be installed by Blue Ox® Dealers who are familiar with our products and have the equipment necessary and knowledge to do “fit work”. When necessary Blue Ox® Dealers can be found at [www.blueox.us](http://www.blueox.us) or by contacting our 24/7 Customer Care Department at (402) 385-3051 or toll free (888) 425-5382.
- Many Blue Ox® Baseplates are designed to use existing holes and hardware to mount the baseplate to the towed vehicle. Even though bolts are there, do not assume they are adequate for baseplate mounting. Always use hardware supplied in the hardware kit and existing hardware specified in the Baseplate Installation Instructions.

Attachment Tab Height: 13”  
 Attachment Tab Width: 24”

Confirm the towability and pre-towing procedures for your vehicle with the owner’s manual or contact the vehicle’s manufacturer for specific towing procedures. You can also contact REMCO for additional information at 1(800)228-2481.

**⚠ WARNING**

Failure to read and follow these instructions could result in separation of the towed vehicle from the tow bar, causing property damage, loss of towed vehicle, personal injury or death.

**Bolt Torque Specifications**  
Torque in Foot-Pounds per Metric Bolts

Bolt Size	Grade 8.8	Grade 10.9
6MM	6	8
8MM	16	22
10MM	31	40
12MM	54	70
14MM	89	117

**Bolt Torque Specifications**  
Torque in Foot-Pounds per Inch Bolts

Bolt Size	Grade 5	Grade 8
1/4”	10	14
5/16”	19	29
3/8”	33	47
7/16”	54	78
1/2”	78	119
5/8”	154	230

# BX1935 1998-00 Chrysler Town & Country 1998-00 Dodge Caravan (including Grand Caravan) 1998-00 Plymouth Grand Voyager Installation Instructions

## Parts List

Ref. No.	Qty.	Part #	Description
1	1	61-5167	Weldment, Baseplate, BX1935
2	2	102-5300	Weldment, Side Brace, BX1935
3	2	61-4931	1/2" Nut Plate, with Wire
4	4	201-0011	1/2-13 x 1 1/4" Hex Bolt, Grade 5
5	6	203-0012	1/2" Lock Washer
6	4	61-4029	1/2" Wire Nut
7	2	201-0283	1/2-13 x 2" Hex Bolt, Grade 5

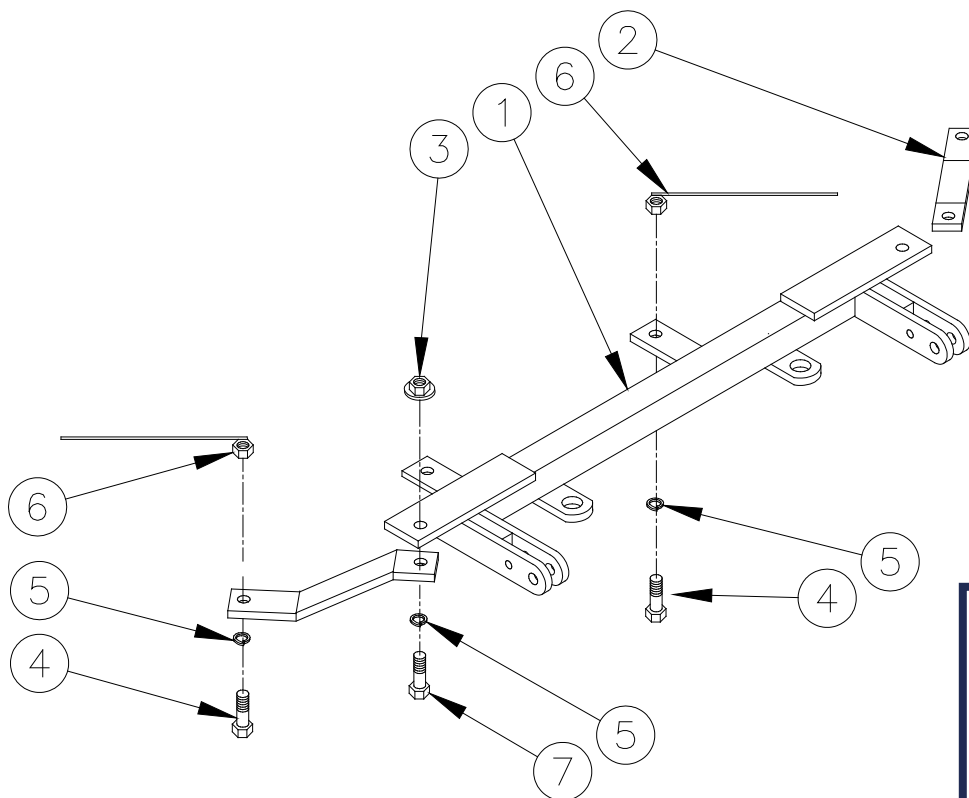

## Tools Required

3/4" Wrench  
10MM Wrench  
17/32" Drill Bit  
Phillips Screwdriver  
LOCTITE Red

### Important:

Use only genuine factory replacement parts on your baseplate. Do NOT substitute homemade or non-typical parts. If a bolt is lost or in need of replacement, for your safety and the preservation of your baseplate, be sure to use a replacement bolt of the same grade (In most cases it will be Grade 5, please reference the parts list above). Replacement parts may be ordered through your nearest Blue Ox® Dealer or Distributor, or call our 24/7 Customer Care Team at (402)385-3051.

BX1935  
1998-00 Chrysler Town & Country  
1998-00 Dodge Caravan (including Grand Caravan)  
1998-00 Plymouth Grand Voyager  
**Installation Instructions**

## Standard Tab Spacing Guidelines:

To use certain adapters or a RangeFinder II tow bar in conjunction with standard tab baseplates an additional 5/16" hole must be drilled in the attachment tabs. The Ambassador tow bar will require an adapter for attachment tabs that are not 24" wide. The Adventurer tow bar will require an adapter for attachment tabs that are less than 24" wide. The Acclaim tow bar will not fold and store without the use of an adapter on vehicles with attachment tabs less than 24" wide. The BX88152 adapter cannot be used with this baseplate.

## Instruction Notes:

Installation of this baseplate requires removing the bumper and the black plastic air dam. Holes will need to be drilled into the frame of the vehicle. Both the bumper and the air dam will need to be trimmed.

The dimensional variations between otherwise identical vehicles can be considerable. While the baseplate was designed for easy installation, it may be necessary to tailor the baseplate slightly to compensate for auto manufacturer's tolerances. These minor adjustments may include filing a hole slightly, bending electrical rods, and/ or bending end plates.

These vehicles weigh over 3500 lbs. and require a Class III (5,000 lbs) rated tow bar, hitch, and accessories. Utilization of Blue Ox baseplates with any tow bar not approved by Automatic Equipment Mfg. Co. invalidates the warranty.

## Installation Instructions

1. Read the Baseplate General Instructions Sheet included with this baseplate.
2. The bumper will need to be removed so the baseplate can be attached to the frame of the vehicle. There are five screws and two bolts on the top of the bumper and four bolts (two on each side) that connect the bumper to the side quarter panels. To get to these bolts, remove three of the Phillips screws that hold the fender well molding to the bumper. You will need a 10MM wrench and a Phillips screwdriver. There are also ten push plugs on the bottom of the bumper that need to be removed. Disconnect the electrical connections to the lights before removing the bumper.
3. The black plastic air dam will need to be removed next. There are six bolts that will need to be removed. You will need a 10MM wrench for these bolts.

**Figure 1**

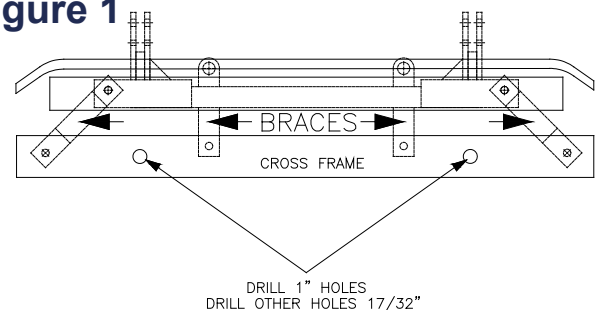

BX1935  
1998-00 Chrysler Town & Country  
1998-00 Dodge Caravan (including Grand Caravan)  
1998-00 Plymouth Grand Voyager  
**Installation Instructions**

4. When the plastic bumper molding is removed, you will see a metal bumper with slotted holes in it. Center the baseplate, left to right under the bumper and be certain the holes in the braces extend over the cross frame of the vehicle to allow drilling and bolting. When the baseplate is centered correctly, mark and drill 17/32" holes.
5. The two braces that extend to the back frame will need to have 17/32" holes drilled also. Holes for the wire nuts also need to be drilled. There are slotted holes that need to be drilled to 1" holes. There are two braces that extend from the outside of the baseplate to the outside edge of the frame. Bolt the braces to the baseplate and move them to the side of the frame, drill 17/32" holes.
6. Bolt the baseplate to the frame, once all the bolts have been started, **APPLY LOCTITE RED**, and tighten all the bolts.
7. The air dam and bumper can now be replaced. Both will need to be trimmed because of the braces and the baseplate. Start with the air dam and then the bumper.

Install the tow bar and safety cables according to the instructions included in their packages.

Do not substitute other devices if the tow bar pin and clip are lost.

**DEALER OR INSTALLER:** BE CERTAIN THE USER RECEIVES THE INSTRUCTION SHEETS.

## Customer Service Commitment

Blue Ox® is focused on providing exemplary customer service, as observed in our mission statement and guiding principles. In accordance with this objective, Blue Ox® is proud to provide services such as repairs and general maintenance of Blue Ox® products at over 150 RV Rallies. Look for our Destination America or Blue Ox® Racing service crews at the next rally or race that you attend. If you were not present, you will find an informative, personalized note explaining any services that may have been performed to your Blue Ox® products.

Blue Ox® also offers educational seminars at rallies and through our Parks and Resort teams. In addition, Blue Ox® customers visiting our factory may take advantage of the well-equipped Blue Ox® RV park at no charge to you, our valued and appreciated customer.



© 2005 Blue Ox  
One Mill Road, Industrial Park  
Pender, Nebraska 68047  
Phone: (402) 385-3051  
Toll Free: (888) 425-5382  
Fax: (402) 385-3360  
www.blueox.us  
292-2297