

2007-09 Chrysler Aspen  
2007-09 Dodge Durango  
Installation Instructions

**Serial Number**

**Please read BOTH these Installation Instructions and the General Towing Instructions before attempting to install or operate this equipment.**

- Blue Ox® towing products and accessories are intended to be installed by Blue Ox® Dealers who are familiar with our products and have the equipment and knowledge to do “fit work.” When necessary, Blue Ox® Dealers can be found at [www.blueox.us](http://www.blueox.us) or by contacting our Customer Care Department at (888) 425-5382.
- Many Blue Ox® Baseplates are designed to use existing holes and hardware to mount the baseplate to the towed vehicle. Even though bolts are there, do not assume they are adequate for baseplate mounting. Always use hardware supplied in the hardware kit or existing hardware specified in the Baseplate Towing Installation Instructions.

Attachment Tab Height: 14 1/2”  
Attachment Tab Width: 29”

**Bolt Torque Specifications**

Torque in Foot-Pounds per Metric Bolts

Bolt Size	Grade 8.8	Grade 10.9
6MM	6	8
8MM	16	22
10MM	31	40
12MM	54	70
14MM	89	117

Confirm the towability and pre-towing procedures for your vehicle with the owner’s manual or contact the vehicle’s manufacturer for specific towing procedures. You can also contact REMCO for additional information at 1(800)228-2481.

**Bolt Torque Specifications**

Torque in Foot-Pounds per Inch Bolts

Bolt Size	Grade 5	Grade 8
1/4”	10	14
5/16”	19	29
3/8”	33	47
7/16”	54	78
1/2”	78	119
5/8”	154	230



**! WARNING**

Failure to read and follow these instructions could result in separation of the towed vehicle from the tow bar, causing property damage, loss of towed vehicle, personal injury or death.

BX1977  
 2007-09 Chrysler Aspen  
 2007-09 Dodge Durango  
 Installation Instructions

## Parts List

Ref. No.	Qty.	Part #	Description
1	1	61-6382	Weldment, Baseplate, BX1977
2	6	61-4604	Weldment, 1/2" Nut Plate, w/10" Wire
3	6	201-0051	1/2-13 x 1 1/2" Hex Bolt, GRD. 5, ZP
4	6	203-0012	1/2" Lock Washer, ZP
5	2	201-0553	1/4-20x1/2" Hex WSHD, Type F Screw
6	2	201-0192	#10-32x1/2" Slot, Round Head Screw
7	2	203-0054	#10 Lock Washer
8	2	202-0047	#10-32 Hex Nut
9	2	101-5822	Adapter, 4 Way Connector
10	2	62-3469	Attachment, Assembly, SF/LB, 1 Hole
	2	290-0437	Cap Plug, Black (Not Shown)
	2	229-0512	Quicklink, 1/2", ZP (Not Shown)
	2	226-0049	Baseplate Safety Cable, 36" Class IV (Not Shown)

### Tools Required

Loctite® RED  
 10MM Socket  
 18MM Socket  
 17/32" Drill Bit  
 Hack Saw Knife  
 Vise Grips

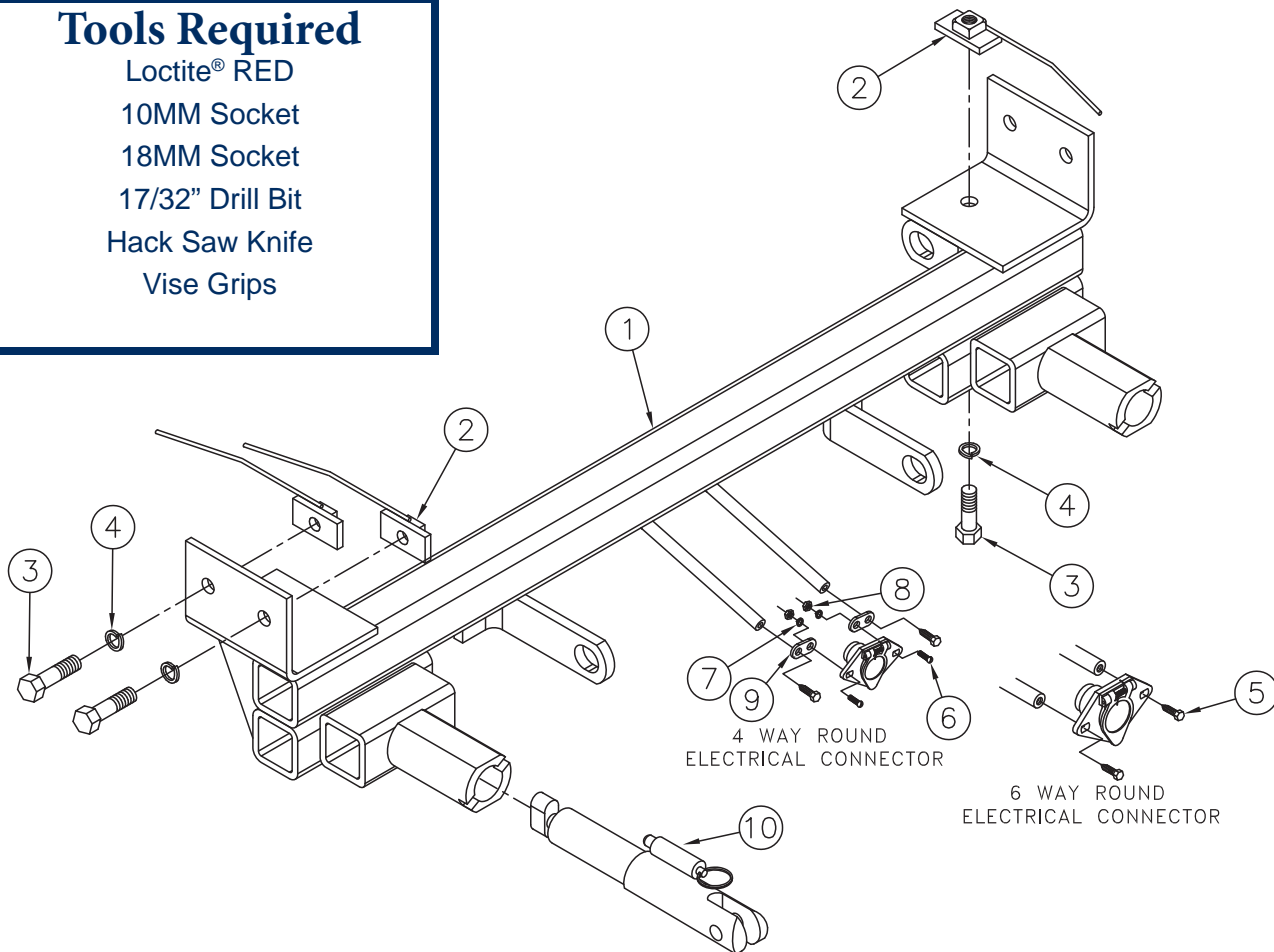

### Important:

Use only genuine factory replacement parts on your baseplate. Do **NOT** substitute homemade or non-typical parts. If a bolt is lost or in need of replacement, for your safety and the preservation of your baseplate, be sure to use a replacement bolt of the same grade (In most cases it will be Grade 5, please reference the parts list above). Replacement parts may be ordered through your nearest Blue Ox® Dealer or Distributor.

BX1977  
2007-09 Chrysler Aspen  
2007-09 Dodge Durango  
Installation Instructions

**Vehicle Weight:**

The weight of this vehicle is near the Class III, 5,000 lb. rating limitations. Some models, depending on options, may well exceed this 5,000 lb. rating. Be sure to confirm the weight of your individual vehicle before towing. As of 1999, the Aventa® II is now 10,000 lbs. and either the Aventa® II or the Aventa® LX tow bar must be used for these applications.

**Tow Bar Adapters are NOT to be used with vehicles weighing over 5,000 lbs.**

**Installation Notes:** The fascia and metal bumper are removed and reinstalled during installation of the baseplate. Drilling is required. Trimming of the fascia is required.

The dimensional variations between otherwise identical vehicles can be considerable. While the baseplate was designed for easy installation, it may be necessary to tailor the baseplate slightly to compensate for auto manufacturer's tolerances. These minor adjustments may include filing a hole slightly, bending electrical rods and/ or bending end plates.

The BX8869 Bulb and Socket Wiring Kit is recommended for this vehicle.



**Installation Instructions:**



1. Using a 10MM socket, remove three metric bolts just forward the front tire, on the wheel well. Once bolts are removed from the wheel well, pull plastic back and remove two metric bolts with a 10MM socket. Set bolts aside to be reinstalled later. Do this to both sides of the vehicle.



2. Using a 10MM socket, remove one metric bolt from the front of the fascia. Set bolt aside to be reinstalled later. Do this to both sides of the vehicle.



BX1977  
2007-09 Chrysler Aspen  
2007-09 Dodge Durango  
Installation Instructions



3. Using a 10MM socket, remove one metric bolt located on the side of the opening in the fascia. Set bolt aside to be reinstalled later. Do this to both sides of the vehicle.

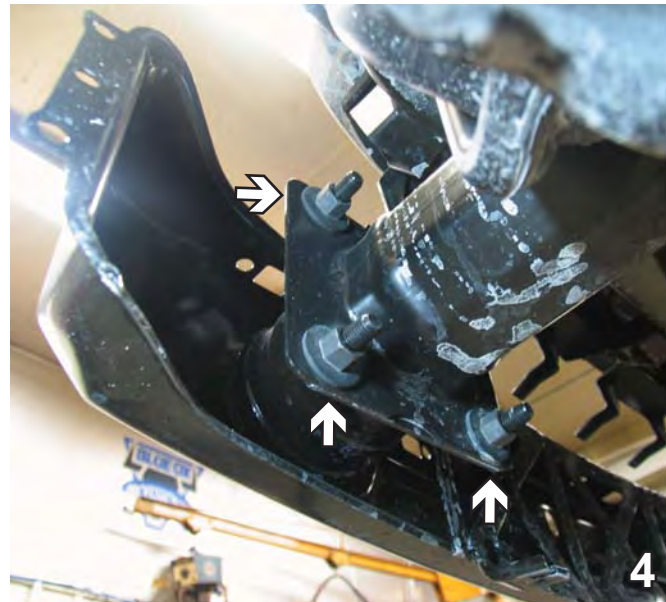

4. Using a 18MM socket, remove three metric nuts from the metal bumper. Set bumper and nuts aside to be reinstalled later. Do this to both sides of the vehicle. Some models may have a tow hook that will need to be removed, if applicable.



5. Lift baseplate straight up and slide forward up to dimple in frame. Baseplate should be straight and clamped into place with vise grips.



6. Using the baseplate as a template, drill two holes into the side of the frame and one hole in the bottom of the frame with a 17/32" drill bit. Place a piece of tubing over drill bit for protection while drilling out holes. Insert the 1/2" nut plates into the frame and align with drilled holes. Insert a 1/2-13X1 1/2" hex bolt and 1/2" lock washer into each hole and tighten down with a 3/4" socket. Do this to both sides of the vehicle.

BX1977  
2007-09 Chrysler Aspen  
2007-09 Dodge Durango  
Installation Instructions

**BE SURE TO USE LOCTITE® RED ON ALL BOLTS BEFORE TIGHTENING. TIGHTEN ALL BOLTS ACCORDING TO THE TORQUE CHART ON THE FRONT PAGE OF THESE INSTRUCTIONS OR ON PAGE 3 OF THE BASEPLATE TOWING GENERAL INSTRUCTIONS.**



7. Attach permanent baseplate safety cables to the convenience link on the baseplate. The photo above shows recommended installation of the cables to frame of vehicle. If vehicle has additional options (not shown above) which interfere with mounting permanent baseplate safety cables, secure the cables to a solid piece of the vehicle frame as described in instructions included with the permanent baseplate safety cables.

8. Reinstall metal bumper, by just barely starting the two outside nuts (leaving them really loose) and then tip bumper out towards the front to start the back nut. You will then be able to tighten down all three nuts.



9. Using a hack saw knife, mark and trim out opening in the fascia for the attachment tabs, using the photos above as a template. Do this to both sides of the vehicle. Models that have tow hooks will not need to cut out opening in fascia.



BX1977  
2007-09 Chrysler Aspen  
2007-09 Dodge Durango  
Installation Instructions

Be sure that **ALL** electrical connections are plugged in properly and functioning **BEFORE** installing the fascia.

Install the tow bar and safety cables according to the instructions provided in their packages. When demonstrating this to the customer, be sure to include all the contents and packages.

Do **NOT** substitute other devices if the tow bar pins and clips are misplaced.

**DEALER or INSTALLER:**  
Be certain the user receives the instruction sheets for their products.



### CUSTOMER SERVICE COMMITMENT

Blue Ox is committed to providing you with exceptional customer care throughout your lifetime with our products. Our team is here to assist you with any questions you may have regarding the performance of your product. Simply call 1-800-228-9289 and you can speak with our customer care team.

Additionally, please visit our website to see which rallies our Destination America team will be attending. For a nominal fee, our service technician will service your towing system to ensure it's in proper working condition. Also as a commitment to our customers, should you visit our factory you can stay at our full service Blue Ox campground at no charge along with enjoying a factory tour.

Again thank you for being our customer and for the confidence you have shown in the performance of our products. It is because of customers like you we enjoy the success we have today.



© 2007, 08 Blue Ox  
One Mill Road, Industrial Park  
Pender, Nebraska 68047  
Phone: (402) 385-3051 • Fax: (402) 385-3360  
[www.blueox.us](http://www.blueox.us)