



BX2160

2002-05 Ford Explorer XLT 2002-05 Mercury Mountaineer Installation Instructions

Serial Number

Please read BOTH these Installation Instructions and the Baseplate General Towing Instructions before attempting to install or operate this equipment.

Attachment Tab Height: 21"

Attachment Tab Width: 18"

- Blue Ox® towing products and accessories are intended to be installed by Blue Ox® Dealers who are familiar with our products and have the necessary equipment and knowledge to do "fit work". When necessary Blue Ox® Dealers can be found at www.blueox.com or by contacting our Customer Care Department at (402) 385-3051 or toll free at (888) 425-5382.
- Many Blue Ox® baseplates are designed to use existing holes and hardware to mount the baseplate to the towed vehicle. Even though bolts are there, do not assume they are adequate for baseplate mounting. Always use hardware supplied in the hardware kit and existing hardware specified in the Baseplate Installation Instructions.

Bolt Torque Specifications
Torque in Foot-Pounds for Metric Bolts

Bolt Size	Grade 8.8	Grade 10.9
6MM	6	8
8MM	16	22
10MM	31	40
12MM	54	70
14MM	89	117

Confirm the towability and pre-towing procedures for your vehicle with the owner's manual or contact the vehicle's manufacturer for specific towing procedures.

Bolt Torque Specifications
Torque in Foot-Pounds for Inch Bolts

Bolt Size	Grade 5	Grade 8
1/4"	10	14
5/16"	19	29
3/8"	33	47
7/16"	54	78
1/2"	78	119
5/8"	154	230

! WARNING

Failure to read and follow these instructions could result in separation of the towed vehicle from the tow bar, causing property damage, loss of towed vehicle, personal injury or death.

BX2160
2002-05 Ford Explorer XLT
2002-05 Mercury Mountaineer
Installation Instructions

Parts List

Ref. No.	Qty.	Part #	Description
1	1	62-5606	Weldment, Baseplate, BX2160
2	6	61-3799	Weldment, 1/2-13 Nutplate
3	6	201-0068	1/2-13 x 1 3/4" Hex Bolt, Grade 5, ZP
4	6	203-0012	1/2" Lock Washer, ZP
5	4	203-0005	1/2" Flat Washer, ZP
6	2	201-0569	1/4-20 x 3/4" Hex Bolt, Grade 5, ZP
7	2	203-0001	1/4" Flat Washer, ZP
8	2	203-0008	1/4" Lock Washer, ZP
9	2	202-0001	1/4-20 Hex Nut, ZP
10	2	201-0192	#10-32 x 1/2" Slot, Rd. Hd. Screw
11	2	203-0054	#10 Lock Washer
12	2	202-0047	#10-32 Hex Nut
13	1	101-6135	Electrical Bracket
14	2	201-0553	1/4-20 x 1/2" Hx Wshd, Type F Screw
	2	226-0049	Baseplate Safety Cable, 36" CL IV (Not Sh.)
	4	229-0512	Quicklink, 1/2, ZP (Not Shown)

Tools Required

15MM Socket	17/32" Drill Bit
10MM Socket	7/32" Drill Bit
3/4" Socket	Flat Screwdriver
7/16" Wrench	Vise Grips
Loctite Red®	

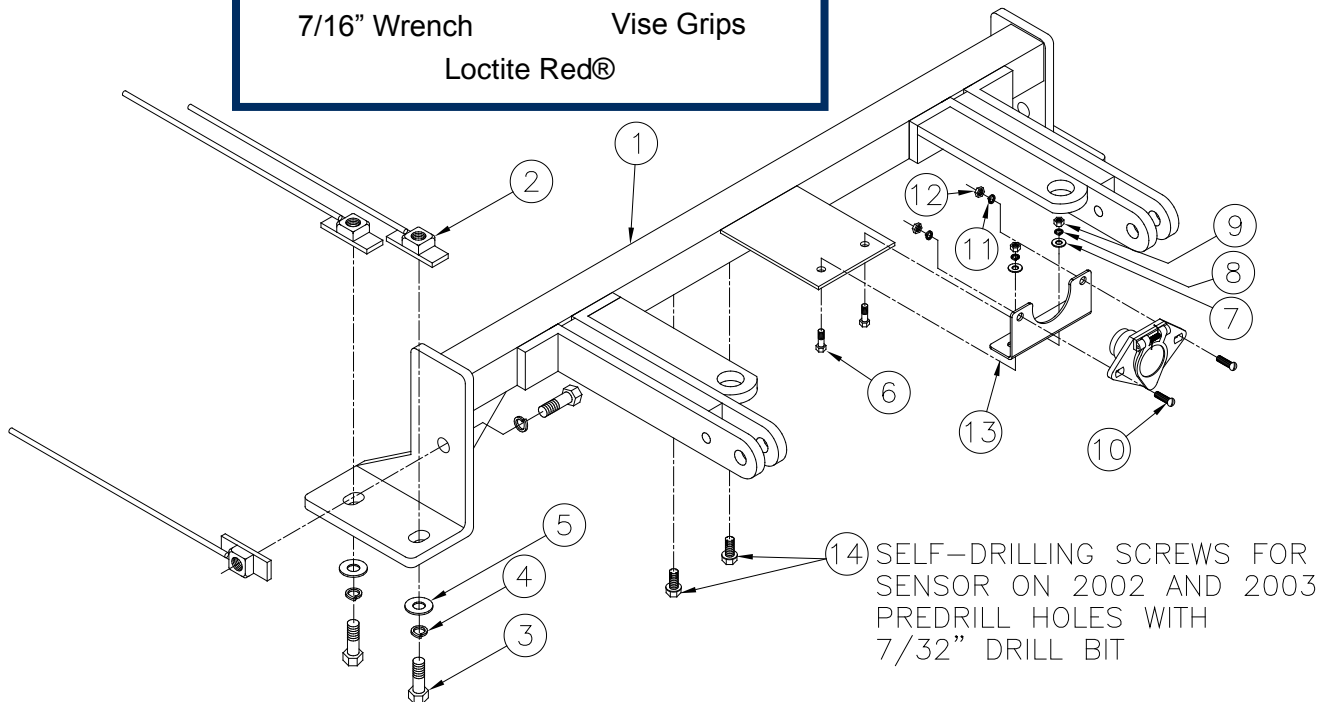

Important:

Use only genuine factory replacement parts on your baseplate. Do NOT substitute homemade or non-typical parts. If a bolt is lost or in need of replacement, for your safety and the preservation of your baseplate, be sure to use a replacement bolt of the same grade. In most cases it will be Grade 5. Please reference the parts list above. Replacement parts may be ordered through your nearest Blue Ox® dealer or distributor, or call our Customer Care Team at (402)385-3051 or toll free (888) 425-5382.

BX2160
2002-05 Ford Explorer XLT
2002-05 Mercury Mountaineer
Installation Instructions

Standard Tabs:

To use certain adapters or a RangeFinder II tow bar in conjunction with standard tab baseplates an additional 5/16" hole must be drilled in the attachment tabs. The Ambassador tow bar will require an adapter for attachment tabs that are not 24" wide. The Adventurer tow bar will require an adapter for attachment tabs that less than 24" wide. The Acclaim tow bar will not fold and store without the use of an adapter on vehicles with attachment tabs less than 24" wide.

Instructions:

The front fascia and bumper is removed and reinstalled for the baseplate installation. Drilling is required. Trimming of the air dam is required.

The dimensional variations between otherwise identical vehicles can be considerable. Although the baseplate was designed for easy installation, it may be necessary to tailor the baseplate slightly to compensate for auto manufacturer's tolerances. These minor adjustments may include filing a hole slightly, bending electrical rods, and/ or bending end plates.

The BX8869, Bulb and Socket Wiring Kit is recommended for this vehicle.



1. Using a Phillips screwdriver, remove two Phillips screws just in front of the front tires on the wheel well. Do this to both sides of the vehicle. Set the screws aside to be reinstalled later.



2. Using a 10MM socket, remove two metric bolts with a 10MM socket and push pins on the bottom side of the fascia. There is a (the 2005 models have two) 10MM bolt to remove inside the wheel well. Do this to both sides of the vehicle. Set the metric bolts aside to be reinstalled later.

BX2160
2002-05 Ford Explorer XLT
2002-05 Mercury Mountaineer
Installation Instructions

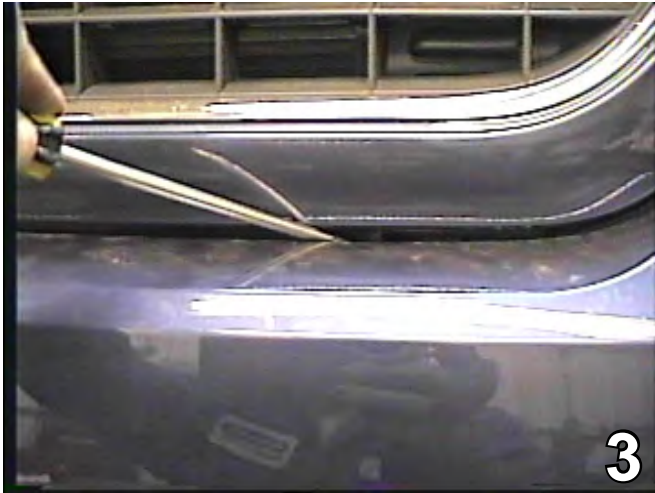

3. There is a slot under each headlight and three under the grille assembly that join the bumper fascia. Insert a flat head screw driver and pry down while pulling the fascia forward. Set the headlight assemble aside to be reinstalled later.

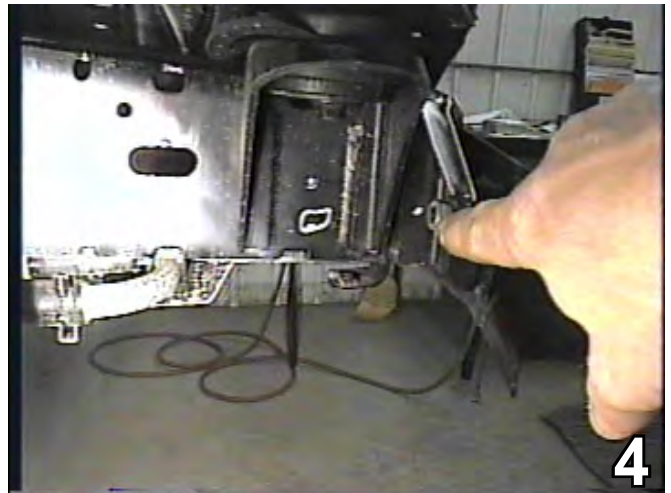

4. Remove the air dam and set aside to be reinstalled later. Using a 15MM socket remove four metric nuts from the metal bumper. Set the metric nuts aside to be reinstalled later. Using the 10MM socket, remove the air bag sensor from the cross member and set out of the way.



5. Hold the baseplate into place and align with the existing holes on the bottom side of the frame. Install the 1/2-13 x 1 3/4" hex washer, 1/2" lock washer, and the 1/2" flat washer. Then insert the 1/2-13 nut plate into the frame end. **(See LOCTITE note)**



6. Using the baseplate as a template, drill a 17/32" hole. Do this to both sides of the vehicle. Install the 1/2-13 nut plate, 1/2-13 x 1 3/4" hex bolt, and the 1/2" lock washer.

BE SURE TO USE LOCTITE® RED ON ALL BOLTS BEFORE TIGHTENING. TIGHTEN ALL BOLTS ACCORDING TO THE TORQUE CHART ON THE FRONT PAGE OF THESE INSTRUCTIONS OR ON PAGE 3 OF THE BASEPLATE TOWING GENERAL INSTRUCTIONS.

BX2160
2002-05 Ford Explorer XLT
2002-05 Mercury Mountaineer
Installation Instructions

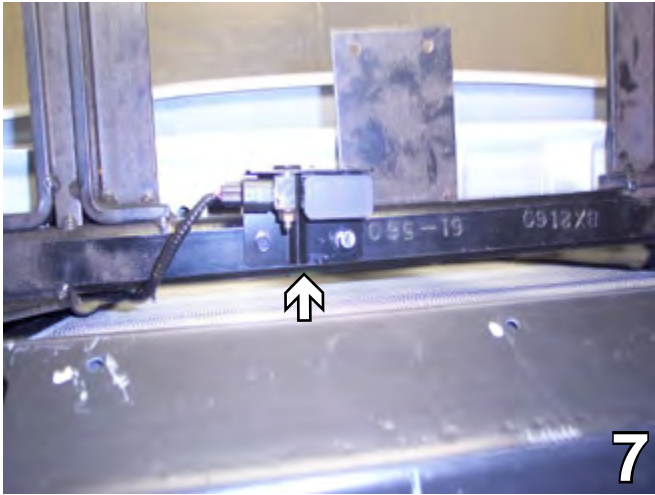

7. 2002-03 Models: Using the air bag sensor as a template, mark and drill two holes on the bottom of the baseplate's cross tube with the 17/32" drill bit. Align the air sensor to drilled holes and install using the 1/4" self tapping screws **Do Not Over Tighten.**

8. Before replacing the air dam, trim to fit around the baseplate. Replace the metal bumper and the fascia.
9. Install the Electrical bracket with the appropriate fasteners. Be sure to use LOCTITE Red on ALL bolts.

Install the tow bar and safety cables according to the instructions included in their packages. Do NOT substitute other devices if the tow bar pin and clip are lost.

DEALER or INSTALLER:
Be certain the user receives the instruction sheets for their products.



BX2160
2002-05 Ford Explorer XLT
2002-05 Mercury Mountaineer
Installation Instructions



Standard Tabs

CUSTOMER SERVICE COMMITMENT

Blue Ox is committed to providing you with exceptional customer care throughout your lifetime with our products. Our team is here to assist you with any questions you may have regarding the performance of your product. Simply call 1-800-228-9289 and you can speak with our customer care team.

Additionally, please visit our website to see which rallies our Destination America team will be attending. For a nominal fee, our service technician will service your towing system to ensure it's in proper working condition. Also as a commitment to our customers, should you visit our factory you can stay at our full service Blue Ox campground at no charge along with enjoying a factory tour.

Again thank you for being our customer and for the confidence you have shown in the performance of our products. It is because of customers like you we enjoy the success we have today.



© 2005,06, 07, 08, 09 Blue Ox
One Mill Road, Industrial Park
Pender, Nebraska 68047
Phone: (402) 385-3051
Fax: (402) 385-3360
www.blueox.us
8/14/09