



Strong As An Ox™

BX2169 Installation Instructions

2004-08 Ford F150 (2WD/4WD) (No Heritage Ed. & FX2)
2007 Ford F150 XLT Super Cad (4WD)
2007 Ford F150 Lariat Super Crew (4WD)

Serial No.

Drilling is required. No trimming is required on the 2004-05 models. 2006 models without tow hooks will be required to trim fascia. Factory tow hooks will not be reinstalled. The BX8869 is available for the vehicle. Attachment Tabs are 29 1/4 inches center to center and a height of 14 1/2 inches.



1. Remove the two metric bolts from the bottom side of tow hooks using the 15MM socket, both sides. Factory tow hooks will not be reinstalled. 2006 models without tow hooks will be required to trim fascia covering the tow hook opening.



2. Align base plate, items 1 and 2 (note locations), with holes for tow hooks and tighten existing bolts using existing nut plate. If tow hooks were not available with your vehicle, insert wire nuts, item 3, into opening on frame to align with existing holes on bottom of frame, tighten 1/2 bolt and lock washer, items 4 and 5. **Be sure and use loctite on all bolts before tightening. Torque all bolts according to torque chart in General Instruction Sheet.**

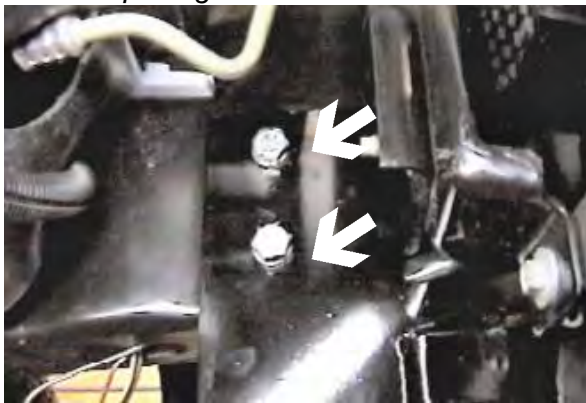

3. Using the baseplate as a template, drill the remaining holes with the 17/32" drill bit. Insert wire nut into opening on frame to align with drilled holes and tighten 1/2-13 x 1 3/4" bolt and lock washer. **Be sure and use loctite on all bolts before tightening. Torque all bolts according to torque chart in General Instruction Sheet.**



View of driver's side.



Tools Required

15MM Socket

Loctite
9/16" Socket

17/32" Drill Bit

Parts List

Ref. No.	Qty.	Part No.	Description
1	1	61-5979	Weldment, Base Plate, DS, BX2169
2	1	61-5980	Weldment, Base Plate, PS, BX2169
3	8	61-4029	1/2" Nut Plate, with Wire
4	8	201-0068	1/2-13 x 1 3/4 Bolt, Grd. 5, ZP
5	8	203-0012	1/2 Lock Washer, ZP
6	1	101-6135	Electrical, Bracket, BX2160
7	4	201-0569	1/4-20 x 3/4 Hex Bolt, Grd. 5, ZP
8	4	203-0008	1/4 Lock Washer, ZP
9	2	203-0001	1/4 Flat Washer, ZP
10	4	202-0069	1/4-20 Hex Whiz Nut, LocZP
11	2	201-0192	#10-32 x 1/2 Slot, Rd. Hd. Screw
12	2	203-0054	#10 Lock Washer
13	2	202-0047	#10-32 Hex Nut
14	2	101-5822	Adapter, 4 Way Connector



Locations for the Bx8869 on driver's side tail light assembly.

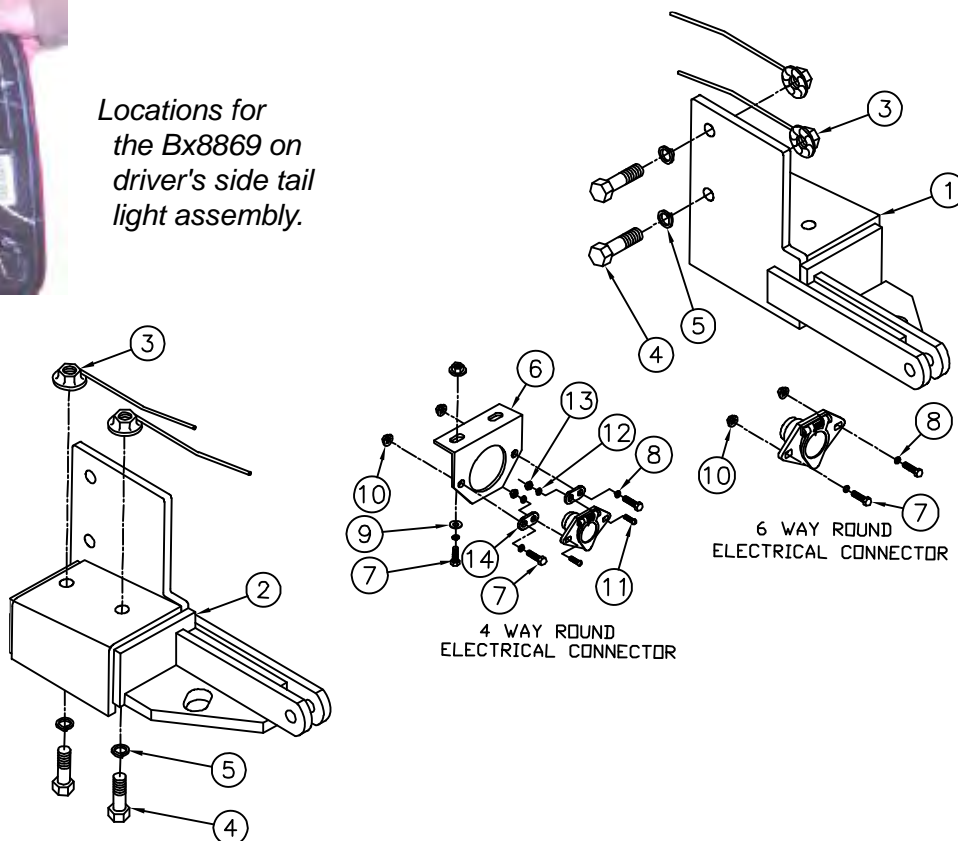

IMPORTANT: Use only genuine factory replacement parts on your Base Plate. Do not substitute homemade or nontypical parts. If a bolt is lost or in need of replacement, for your safety and the preservation of your Base Plate, be sure to use a replacement bolt of the same grade (Usually Grade 5, refer to parts list). Repair parts may be ordered through your nearest **Blue Ox** dealer or distributor.