



BLUE OX®

BX2194

2008-13 Ford 250 Super Duty Installation Instructions

Serial Number

Please read BOTH these Installation Instructions and the General Towing Instructions before attempting to install or operate this equipment.

- Blue Ox® towing products and accessories are intended to be installed by Blue Ox® Dealers who are familiar with our products and have the equipment and knowledge to do “fit work.” When necessary, Blue Ox® Dealers can be found at www.blueox.com or by contacting our Customer Care Department at (402) 385-3051.
- Many Blue Ox® baseplates are designed to use existing holes and hardware to mount the baseplate to the towed vehicle. Even though bolts are there, do not assume they are adequate for baseplate mounting. Always use hardware supplied in the hardware kit or existing hardware specified in the Baseplate Towing Installation Instructions.

Attachment Tab Height: 18”

Attachment Tab Width: 22”

Bolt Torque Specifications

Torque in Foot-Pounds for Metric Bolts

Bolt Size	Grade 8.8	Grade 10.9
6MM	6	8
8MM	16	22
10MM	31	40
12MM	54	70
14MM	89	117

Confirm the towability and pre-towing procedures for your vehicle with the owner’s manual or contact the vehicle’s manufacturer for specific towing procedures.

Bolt Torque Specifications

Torque in Foot-Pounds for Inch Bolts

Bolt Size	Grade 5	Grade 8
1/4”	10	14
5/16”	19	29
3/8”	33	47
7/16”	54	78
1/2”	78	119
5/8”	154	230



If the front of your vehicle looks different than this, call us at (402) 385-3051.



WARNING

Failure to read and follow these instructions could result in separation of the towed vehicle from the tow bar, causing property damage, loss of towed vehicle, personal injury or death.



BX2194

2008-13 Ford 250 Super Duty Installation Instructions

Parts List

Ref. No.	Qty.	Part #	Description
1	1	61-6401	Weldment, Base Plate, BX2194
2	2	201-0350	10MM 5/8-11 x 1 1/2 Hex Bolt
3	2	203-0013	10MM 5/8 Lock Washer, ZP
4	2	202-0008	5/8-11 Hex Nut
5	2	201-0051	1/2-13 x 1 1/2 Hex Bolt
6	2	203-0012	1/2 Lock Washer, ZP
7	2	202-0005	1/2-13 Hex Nut
8	2	201-0553	1/3 x 1/2 Hx. Wshd, Type F
9	2	201-0192	#10-32 x Slot. Rd. Hd. Screw
10	2	203-0054	#10 Lock Washer
11	2	202-0047	#10-32 Hex Nut
12	2	101-5822	Adapter, 4 Way Connector
13	6		Existing Meter Bolts
14	2		Existing Toe Hooks
15	2	62-3469	ATT TAB ASSY, REM, SF/LB, 1 HOLE
	2	290-0437	Cap Plug, Black (Not Shown)
	4	229-0512	Quicklink, 1/2", ZP (Not Shown)
	2	226-0049	Baseplate Safety Cable, 36" Class III (Not Shown)

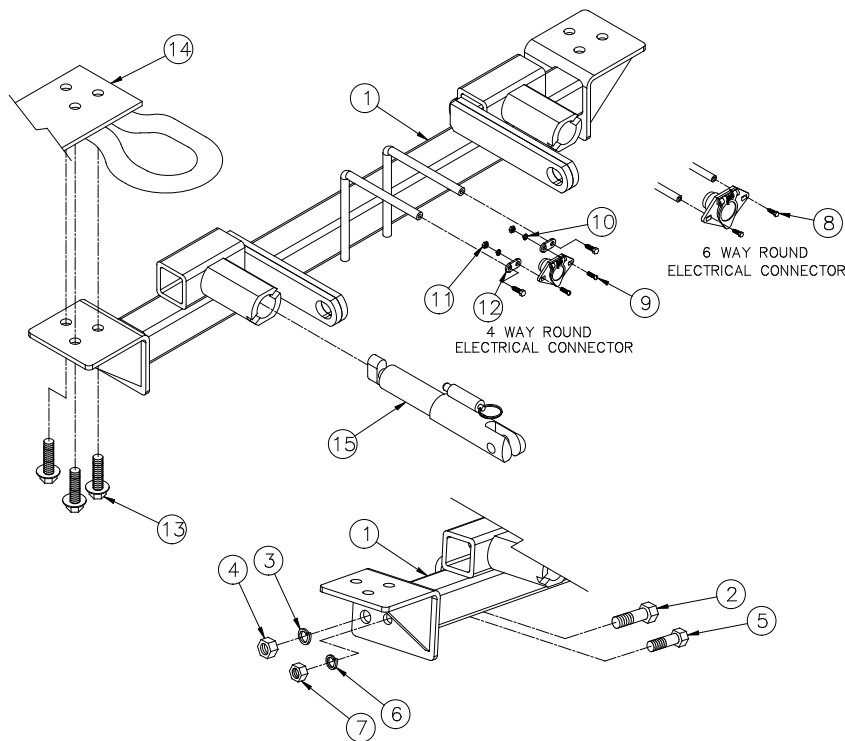

Tools Required

- Loctite® RED
- 8MM Socket
- 13MM Socket
- 15MM Socket
- 18MM Socket
- 17/32" Drill Bit
- 21/32" Drill Bit
- Flat Screwdriver

Important:

Use only genuine factory replacement parts on your baseplate. Do NOT substitute homemade or non-typical parts. If a bolt is lost or in need of replacement, for your safety and the preservation of your baseplate, be sure to use a replacement bolt of the same grade (In most cases it will be Grade 5, please reference the parts list above). Replacement parts may be ordered through your nearest Blue Ox® Dealer or Distributor. Failing to follow and/or altering these installation instructions in either installation or required equipment will void the manufacturer's warranty.



BX2194

2008-13 Ford 250 Super Duty Installation Instructions

Vehicle Weight: The weight of this vehicle is near the Class III, 5,000 lbs. rating limitations. Some models, depending on options, may well exceed this 5,000 lb rating. Be sure to confirm the weight of your individual vehicle before towing and insure your tow bar, hitch and all equipment has an appropriate rating.

Tow Bar Adapters are NOT to be used with vehicles weighing over 5,000 lbs.

Installation Notes: The fascia and air dam are removed for installation.

The dimensional variations between otherwise identical vehicles can be considerable. While the baseplate was designed for easy installation, it may be necessary to tailor the baseplate slightly to compensate for auto manufacturer's tolerances. These minor adjustments may include filing a hole slightly, bending electrical rods or bending end plates.

The BX8869 Bulb and Socket Wiring Kit is recommended for this vehicle.

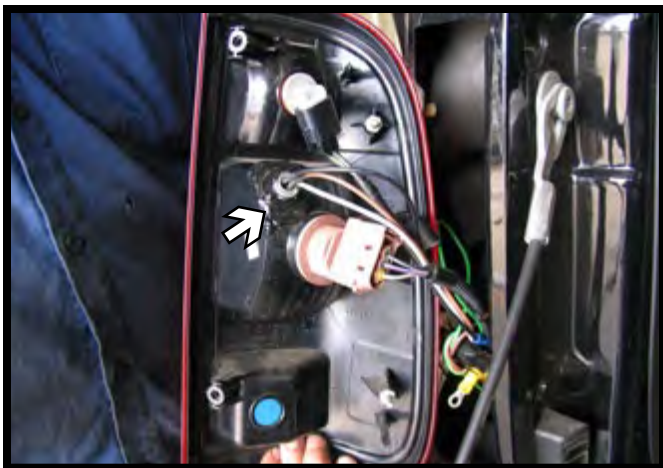

Possible location for the Bulb and Socket Wiring Kit (BX8869)

Handling of some cosmetic parts when installing this product may require the use of protective covers, rags, specialty tools, etc. to prevent damage.

Installation Instructions



1. Using a 18MM socket, remove two metric bolts from the bumper, located just beside the fog light assembly. Do this to both sides of the vehicle. Set bolts aside to be reinstalled later.



2. Just behind the metal bumper on the frame there is a bolt that needs to be removed. Using a 13MM socket. Do this to both sides. Set bolts aside to be reinstalled later.

Do not use the towed vehicle for storing luggage, equipment, etc. This may cause you to exceed the towing capacity of the tow bar, baseplate, and its accessories.



3. Using a flat screwdriver, remove three push pins located just below the license plate. Set push pins aside for later reinstallation.

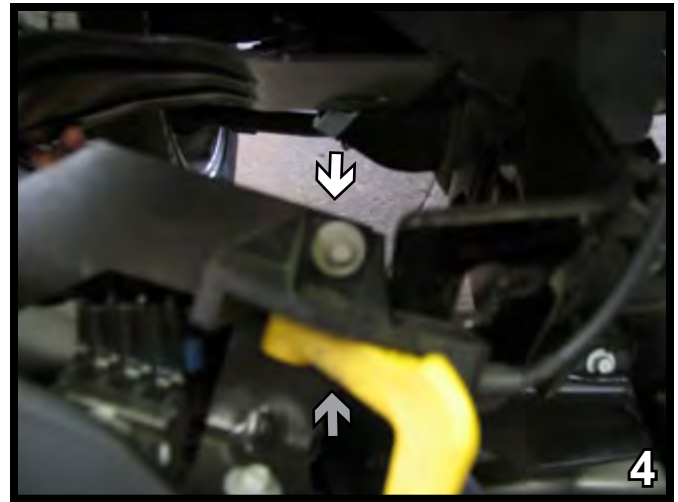

4. While removing the bumper there is a 5MM bolt on the passenger side by a yellow latch. Remove it with a 8MM socket. This is only on the passenger side. Set aside for reinstallation.

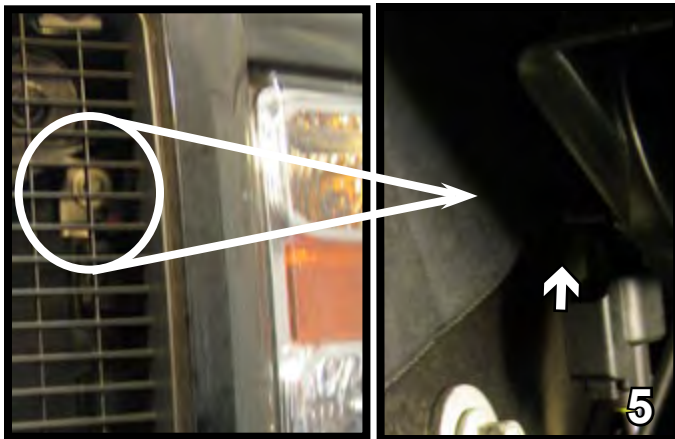

5. A wire harness needs to be unplugged on the drivers side. Pull bumper forward and set aside for later reinstallation.

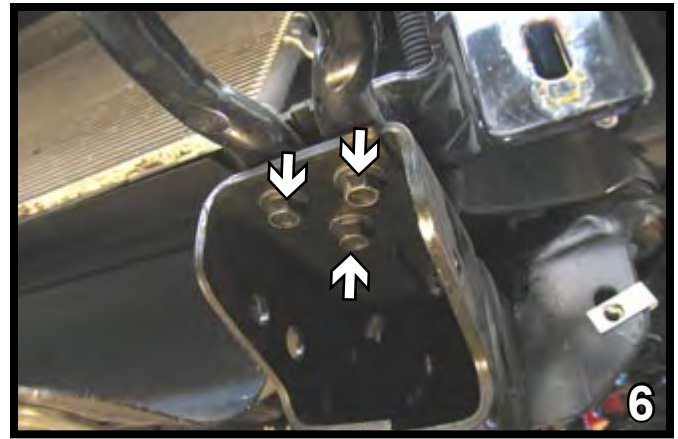

6. Remove the tow hook from both sides by removing the three bolts using a 15MM socket. Set tow hooks aside with the bolts to be reinstalled later.

7. Before sliding on base plate, on the passenger side, there are two coolant lines that are held by a push pin and need to be removed using a flat screwdriver. Install 3 washers between the pushpin and frame to bring the lines are further (see 7B for after photo).

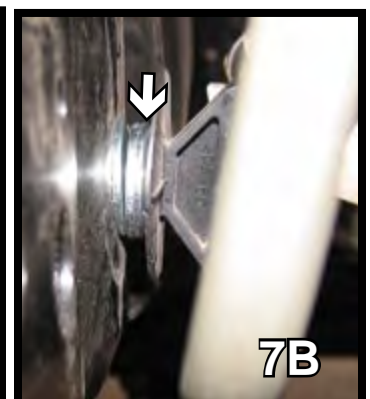
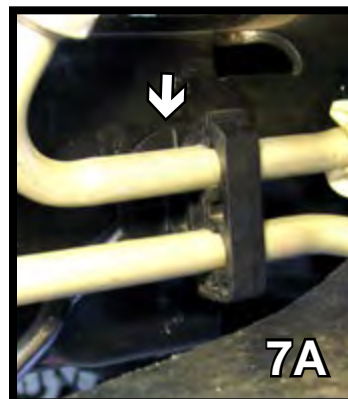



BLUE OX

BX2194

2008-13 Ford 250 Super Duty Installation Instructions

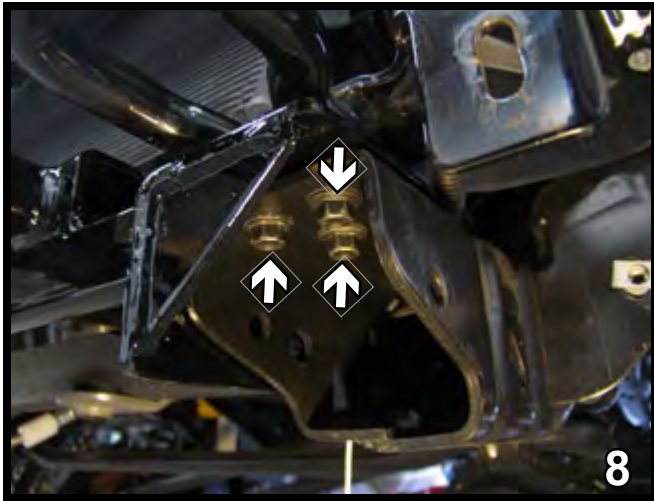

8. Align baseplate with existing tow hook holes and install existing bolts and tow hooks on top of the baseplate. Do to both sides.



9. It may be necessary to ream out two existing holes on the side of the frame rail. Using the baseplate as a template, drill out the front hole with the 17/32" drill bit and a 21/32" drill bit on the back hole. Not every frame will be the same as you can note above. Do this to both sides.



10. Attach the permanent baseplate safety cables to the provided convenience link on the baseplate. The photo above shows the recommended installation of the cables to frame of vehicle. Additional options may interfere with suggested mounting; in this case secure the cables to a solid piece of the frame as described in the instructions included with the permanent baseplate safety cables. Be sure the safety cables do not rub against any hoses or moving parts. Do this to both sides of the vehicle.

BE SURE TO USE LOCTITE® RED ON ALL BOLTS BEFORE TIGHTENING. TIGHTEN ALL BOLTS ACCORDING TO THE TORQUE CHART ON THE FRONT PAGE OF THESE INSTRUCTIONS OR ON PAGE 3 OF THE BASEPLATE TOWING GENERAL INSTRUCTIONS.

Be sure that ALL electrical connections are plugged in properly and functioning BEFORE installing the fascia.

11. Reinstall fascia, bolts and push pins. The installation of the baseplate is complete.

Install the tow bar and safety cables according to the instructions provided in their packages. When demonstrating this to the customer, be sure to include all the contents and packages.

Do **NOT** substitute other devices if the tow bar pins and clips are misplaced.



BX2194

2008-13 Ford 250 Super Duty Installation Instructions

DEALER or INSTALLER:

Be certain the user receives the instruction sheets for their products.



Shown with removable tabs installed



Shown without removable tabs installed

If the baseplate is in an accident, it must be replaced. **DO NOT** use it again! An accident can cause unseen damage and using it again could result in more damage or serious injury. **DO NOT** use the baseplate if it is damaged or missing parts.

CUSTOMER SERVICE COMMITMENT

Blue Ox is committed to providing you with exceptional customer care throughout your lifetime with our products. Our team is here to assist you with any questions you may have regarding the performance of your product. Simply call 1-800-228-9289 and you can speak with our customer care team.

Additionally, please visit our website to see which rallies our Destination America team will be attending. For a nominal fee, our service technician will service your towing system to ensure it's in proper working condition. Also, as a commitment to our customers, should you visit our factory you can stay at our full service Blue Ox campground at no charge along with enjoying a factory tour.

Again, thank you for being our customer and for the confidence you have shown in the performance of our products. It is because of customers like you we enjoy the success we have today.



© 2007, 08, 09, 11 Blue Ox
One Mill Road, Industrial Park
Pender, Nebraska 68047

Phone: (402) 385-3051 • Fax: (402) 385-3360
www.blueox.com