



BLUE OX®

BX2256

2012 Honda Civic (No Foglights) Installation Instructions

Please read BOTH these Installation Instructions and the General Instructions before attempting to install or operate this equipment.

Serial Number

- Blue Ox® towing products and accessories are intended to be installed by Blue Ox® Dealers who are familiar with our products and have the equipment necessary and knowledge to do “fit work”. When necessary Blue Ox® Dealers can be found at www.blueox.com or by contacting our Customer Care Department at (402) 385-3051.

Attachment Tab Height: 14-1/2”

Attachment Tab Width: 24”

- Many Blue Ox® baseplates are designed to use existing holes and hardware to mount the baseplate to the towed vehicle. Even though bolts are there, do not assume they are adequate for baseplate mounting. Always use hardware supplied in the hardware kit and existing hardware specified in the Baseplate Installation Instructions.

Bolt Torque Specifications

Torque in Foot-Pounds for Metric Bolts

Bolt Size	Grade 8.8	Grade 10.9
6MM	6	8
8MM	16	22
10MM	31	40
12MM	54	70
14MM	89	117

Confirm the towability and pre-towing procedures for your vehicle with the owner’s manual or contact the vehicle’s manufacturer for specific towing procedures.

Bolt Torque Specifications

Torque in Foot-Pounds for Inch Bolts

Bolt Size	Grade 5	Grade 8
1/4”	10	14
5/16”	19	29
3/8”	33	47
7/16”	54	78
1/2”	78	119
5/8”	154	230



If the front of your vehicle looks different than this, call us at (402) 385-3051.



WARNING

Failure to read and follow these instructions could result in separation of the towed vehicle from the tow bar, causing property damage, loss of towed vehicle, personal injury or death.



BLUE OX®

BX2256

**2012 Honda Civic (No Foglights)
Installation Instructions**

Tools Required

- Large Vise Grip
- Flat Screwdriver
- Utility Knife
- Phillips Screwdriver
- Torque Wrench
- Drill
- Reciprocating Saw
- Tape Measure
- Loctite® RED
- 1-1/4" Hole Saw
- 5/16" Drill Bit
- 13/32" Long Drill Bit
- 10MM Socket
- 12MM Socket
- 7/16" Socket
- 7/16" Wrench
- 9/16" Socket
- 9/16" Wrench
- T30 Torx

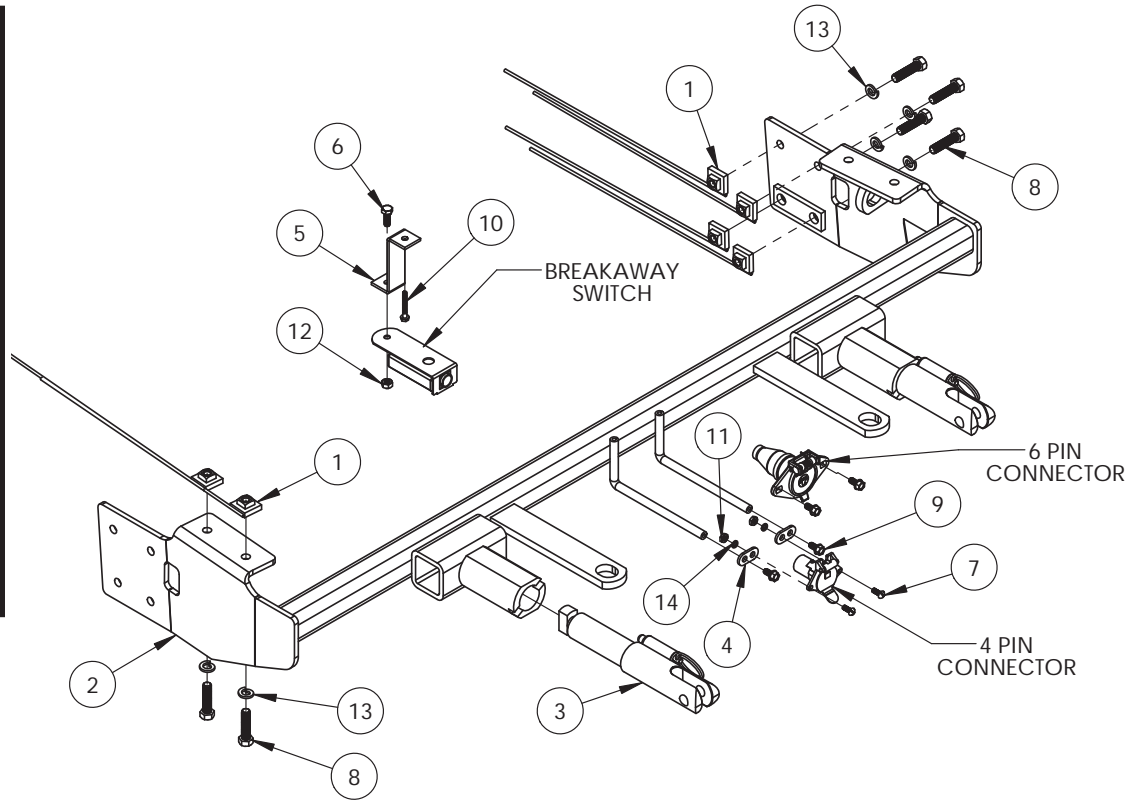

Item No.	Part No.	Description	Qty.
1.....	61-5208.....	3/8"-16 Nut Plate w/ 14" Wire.....	12
2.....	61-6894.....	BX2256 Baseplate.....	1
3.....	62-3469.....	Attachment Tab Assembly with Hole.....	2
4.....	101-5822.....	4 Way Connector Adapter.....	2
5.....	102-7168.....	Breakaway Bracket.....	1
6.....	201-0050.....	1/4"-20 x 3/4" Hex Head Bolt, Grade 5, ZP.....	2
7.....	201-0192.....	#10-32 1/2" Round Slotted Head Screw.....	2
8.....	201-0440.....	3/8"-16 x 1-1/2" Hex Head Bolt, Grade 5, ZP.....	12
9.....	201-0553.....	1/4-20 x 1/2" Hex Wshd Bolt Type F TCS, ZP.....	2
10.....	201-0654.....	#10-16 x 1" Self Drilling Screw, ZP.....	1
11.....	202-0047.....	#10-32 Hex Nut.....	2
12.....	202-0102.....	1/4"-20 Hex Nylon Nut, ZP.....	1
13.....	203-0010.....	3/8" Lock Washer, ZP.....	12
14.....	203-0054.....	#10 Lock Washer, ZP.....	2
15.....	202-0069 (not shown).....	1/4"-20 Hex Whiz Lock Nut.....	1
16.....	203-0001 (not shown).....	1/4" Flat Washer, ZP.....	2
17.....	203-0008 (not shown).....	1/4" Lock Washer, ZP.....	2
18.....	226-0046(not shown).....	Class III Safety Cables.....	2
19.....	229-0359(not shown).....	3/8" Quicklink, ZP.....	2
20.....	290-0437(not shown).....	Black Cap Plug Receiver.....	2

Important:

Use only genuine factory replacement parts on your baseplate. Do **NOT** substitute homemade or non-typical parts. If a bolt is lost or in need of replacement, for your safety and the preservation of your baseplate, be sure to use a replacement bolt of the same grade (In most cases it will be Grade 5, please reference the parts list above). Replacement parts may be ordered through your nearest Blue Ox® Dealer or Distributor. Failing to follow and/or altering these installation instructions in either installation or required equipment will void the manufacturer's warranty. Towing behind a non-motorized vehicle will void the warranty.



BLUE OX®

BX2256

2012 Honda Civic (No Foglights) Installation Instructions

Attachment Tabs: Due to the design of the removable tabs, the RangeFinder II tow bar can not be used. Adapters, except the BX8833 and BX88151, can not be used with this baseplate.

Instruction Notes: The front fascia, air baffle, windshield washer reservoir, styrofoam and metal bumper are removed and reinstalled during baseplate installation. Drilling is required. Trimming is required.

The dimensional variations between otherwise identical vehicles can be considerable. Although the baseplate was designed for easy installation, it may be necessary to tailor the baseplate slightly to compensate for auto manufacturer's tolerances. These minor adjustments may include filing a hole slightly, bending electrical rods or bending end plates.

The BX8869 Bulb and Socket Wiring Kit is available for this vehicle.



Possible location for Bulb and Socket Wiring Kit (BX8869)

Handling of some cosmetic parts when installing this product may require the use of protective covers, rags, specialty tools, etc. to prevent damage.

Do not use the towed vehicle for storing luggage, equipment, etc. This may cause you to exceed the towing capacity of the tow bar, baseplate, and its accessories.

Installation Instructions:

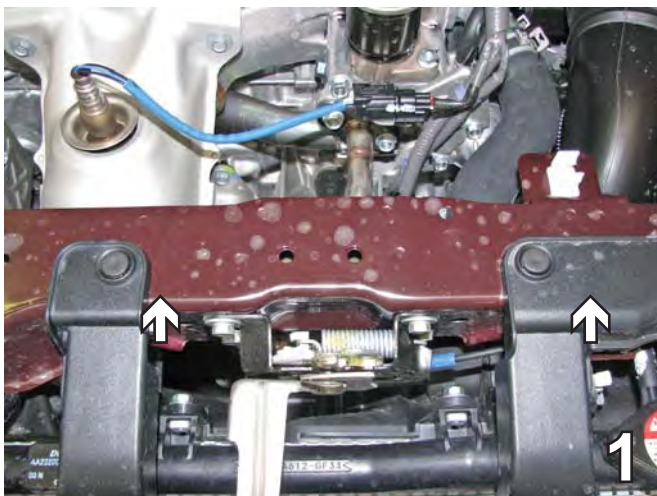

1. Using a flat screwdriver, remove two push pins from the cover on the top of the fascia. Set push pins aside to be reinstalled later.
2. Using a T30 Torx , remove the bolt on the front side of the cover. Do this on both sides of the vehicle. Set bolt aside to be reinstalled later.



BLUE OX®

BX2256

2012 Honda Civic (No Foglights) Installation Instructions



3. Underneath the fascia in the corner in front of the tire, remove one push pin. Do this on both sides of the vehicle. Set push pins aside to be reinstalled later.



4. Along the bottom edge of the fascia, remove five push pins. Do this on both sides of the vehicle. Set push pins aside to be reinstalled later.

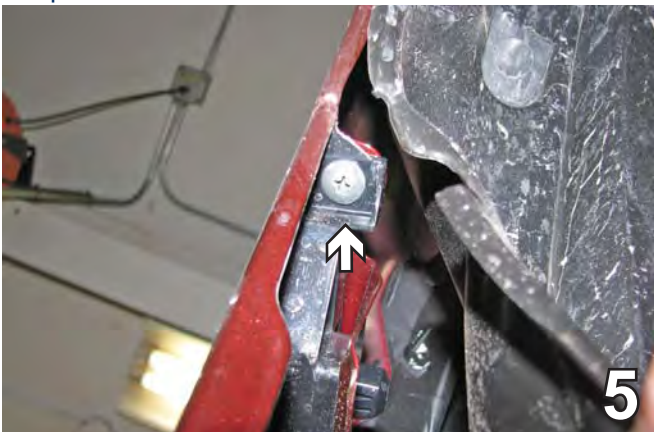

5. Just forward of the front tire, move the wheel well cover back. Using a Phillips screwdriver, remove the screw from the corner of the fascia. Do this on both sides of the vehicle. Set screws aside to be reinstalled later.



6. Lift and pull up on the outside corner of the fascia next to the wheel to release the tabs. Do this on both sides. Set fascia aside carefully to be reinstalled later.

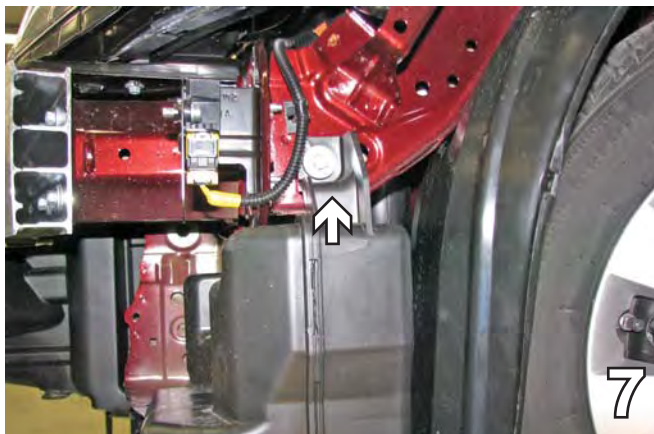

7. On the driver side, using a 10MM socket, remove the metric bolt from the top of the air baffle. Set air baffle and bolt aside to be reinstalled later.

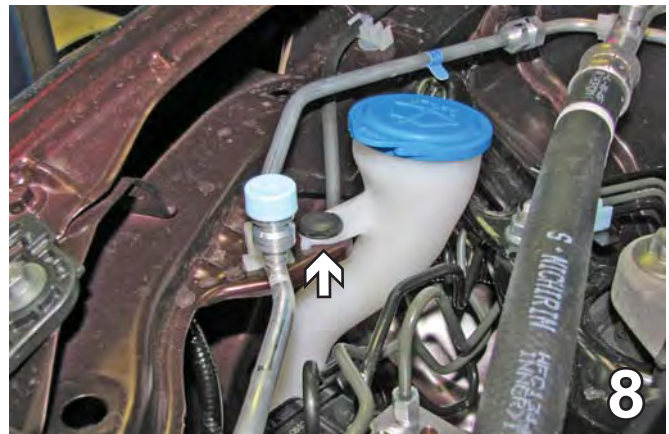

8. On the passenger side, remove the push pin on the top of the washer reservoir by the motor. Set push pin aside to be reinstalled later.



BLUE OX®

BX2256

2012 Honda Civic (No Foglights)
Installation Instructions

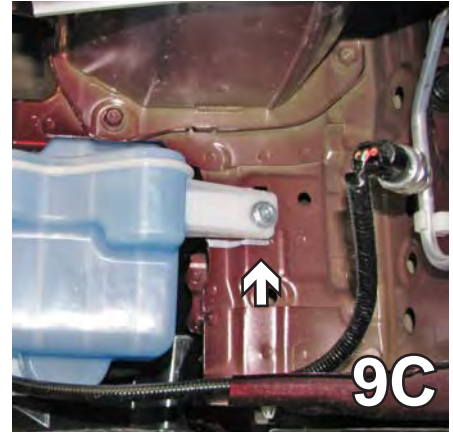
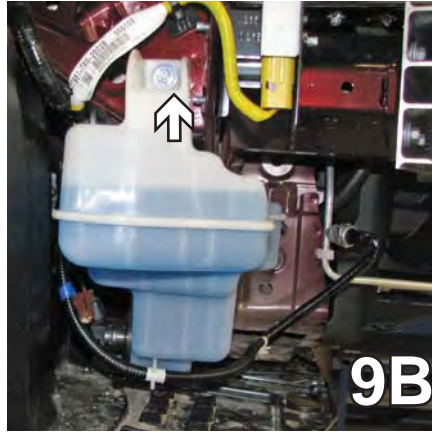
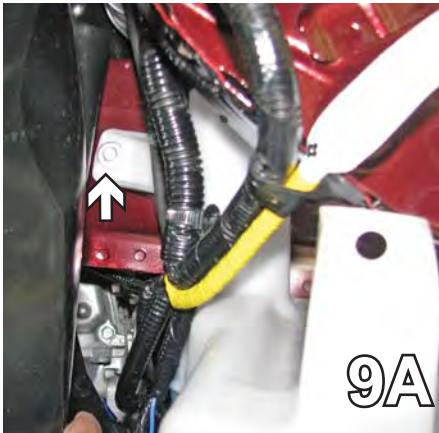

9. Before removing the washer reservoir, mark the location of the reservoir support on the top and bottom of the frame end 9C for step 14. On the passenger side, using a 10MM socket, remove the bolts on the left side of the washer reservoir (9A), on the top (9B) and on the right side (9C). Unplug and disconnect the washer reservoir hoses and lines and plug the hoses. Set bolts and washer reservoir aside to be reinstalled later.



NOTE: Some models may be equipped with a different washer reservoir as shown in the picture above (9D). If the washer reservoir in your vehicle is the same as the one shown in 9D, trimming will be required to accommodate the baseplate installation. With a utility knife, trim a notch out of the reservoir as shown

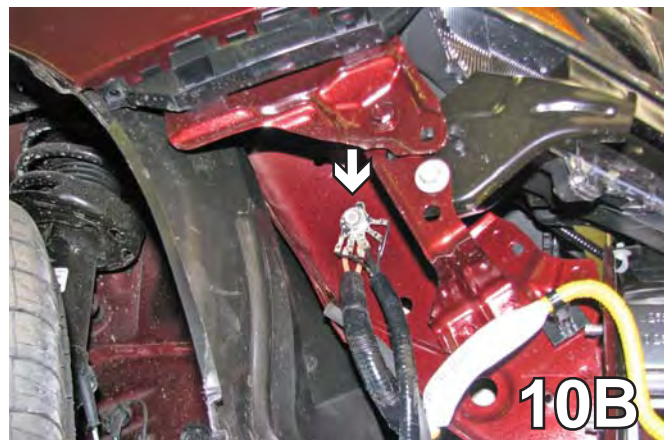
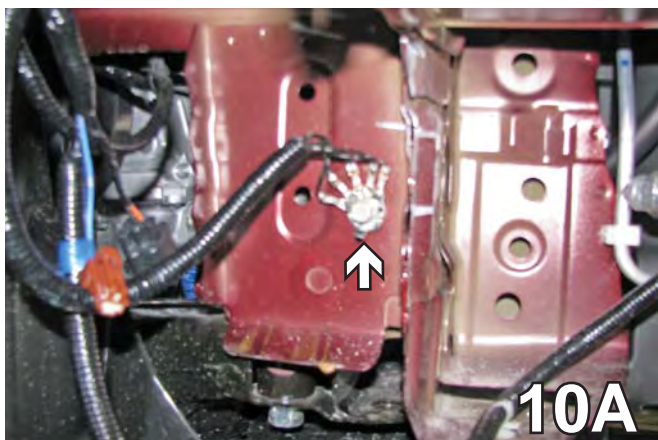

10. On the passenger side, remove the ground wire from the frame rail (10A). Relocate and secure the ground wire to the upper section of the frame rail with a 10MM socket (10B).



BLUE OX

BX2256

2012 Honda Civic (No Foglights) Installation Instructions



11. On the driver side, remove the ground wire from the frame rail (11A). Using 5/16" drill bit, drill a hole through the bracket in the upper section of the frame rail. Relocate and secure the ground wire with a 1/4-20 x 3/4" hex bolt and 1/4-20 whiz nut using a 7/16" socket/wrench (11B).

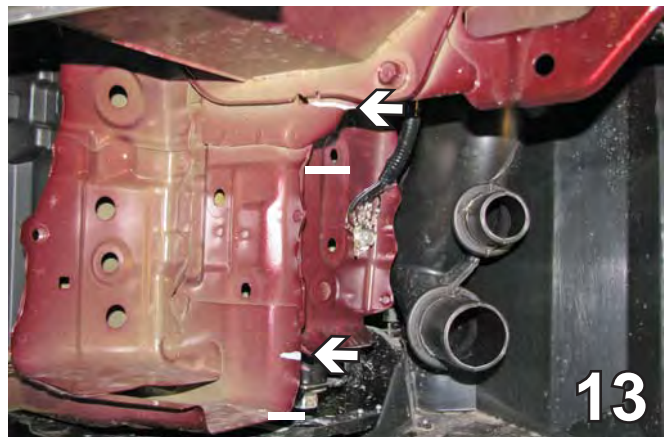

12. Lift up on the notch in the styrofoam and pull out. Do this on both sides. Set the styrofoam aside to be reinstalled later.

13. On the driver side, using the reciprocating saw, cut webbing to the surface of the frame at the top and the bottom of the frame rail. Using a vise grip, bend the middle piece forward toward the front of the car. Bend until it is flat against the frame end. Be careful of sharp edges.

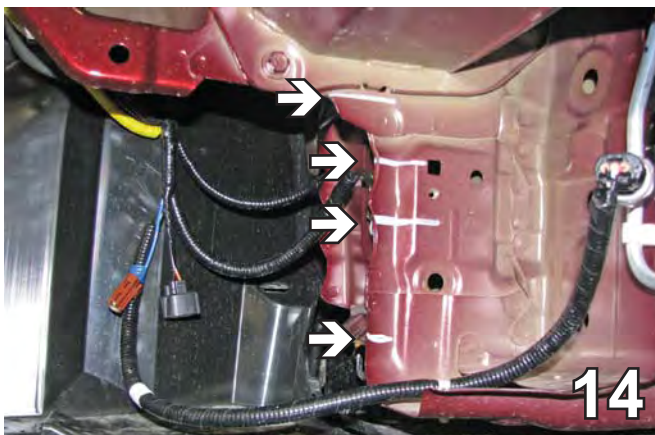

14. On the passenger side, using the reciprocating saw, make four cuts in the frame webbing to the surface of the frame rail. One at the top, one above and one below the washer reservoir connecting hole (from step 9) and one at the bottom. Using a vise grip, bend the top and bottom sections forward and flat against the frame end. Then bend the section of the washer reservoir back flat against the frame rail side.



BLUE OX®

BX2256

**2012 Honda Civic (No Foglights)
Installation Instructions**

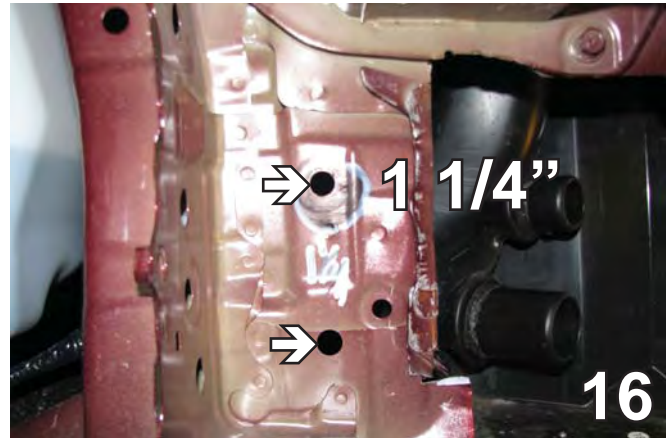
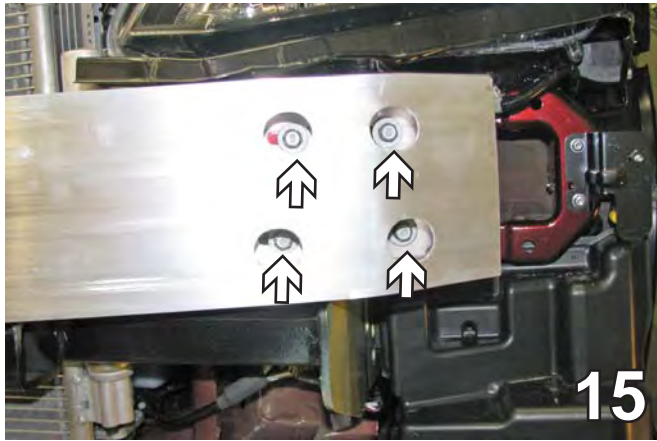

- 15. Using the 12MM socket, remove the four metric bolts from the bumper. Do this on both sides of the bumper. Set bumper and bolts aside. It will be reinstalled with the styrofoam.
- 16. Using the 1 1/4" hole saw, drill a hole in the lower frame rail end next to the radiator using the small hole as a center point. Do this on both sides of the vehicle in order to insert 3/8" nut plates. An additional hole may be required directly underneath.

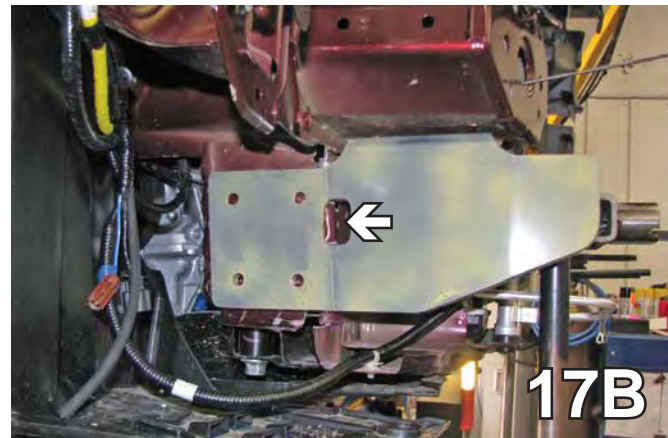
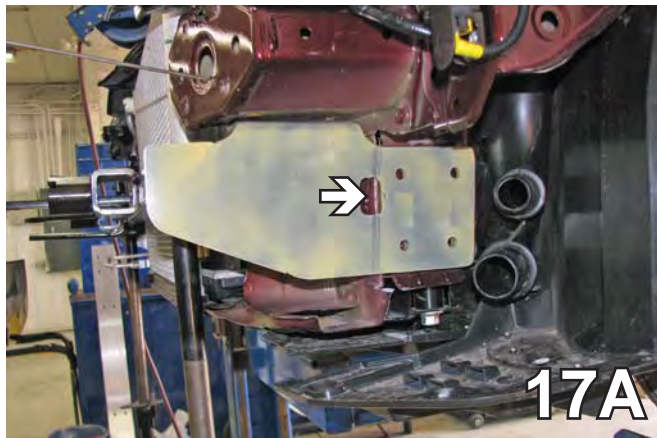

- 17. Slide the baseplate up onto the frame rail. The back of the large rectangular cutout should be flush with the front of the frame rails. Be sure the baseplate is level with respect to the vehicle frame and clamp with the large vise grip. Remember to use Loctite Red on all the bolts. Do this to both sides of the vehicle.

*Baseplate painted yellow for illustration.
Actual baseplate will be powder-coated black.*

When using power drills, be aware of the dangers of torque and drill bit length.

****BE SURE TO USE LOCTITE® RED ON ALL BOLTS BEFORE TIGHTENING. TIGHTEN ALL BOLTS ACCORDING TO THE TORQUE CHART ON THE FRONT PAGE OF THESE INSTRUCTIONS OR ON PAGE 3 OF THE BASEPLATE TOWING GENERAL INSTRUCTIONS.**



BLUE OX®

BX2256

2012 Honda Civic (No Foglights)
Installation Instructions

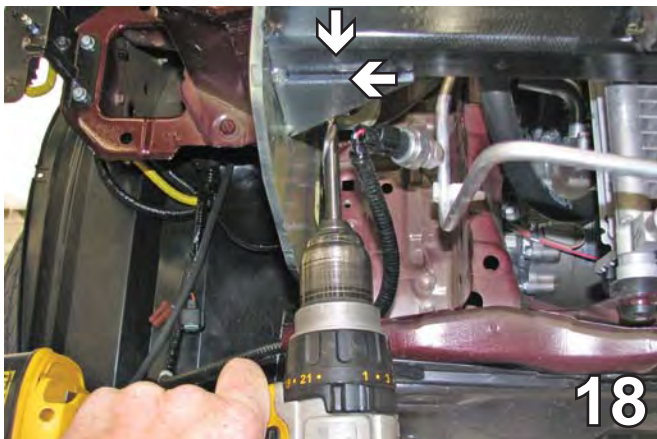

18. Using the baseplate as a template, drill the two holes on the bottom side with the 13/32" extra long 6" drill bit. Do this on both sides of the vehicle.

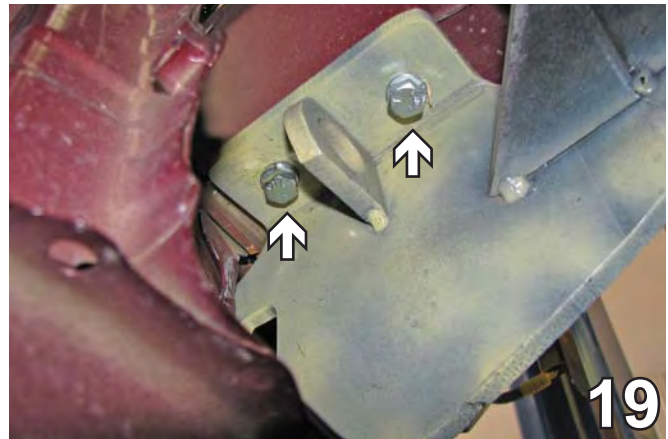

19. Install 3/8-16 x 1 1/2" hex bolt, 3/8" lock washer and 3/8" nut plate inserted through the opening in the frame extension. Be sure to use Loctite Red on all the bolts. Do this to both sides of the vehicle.

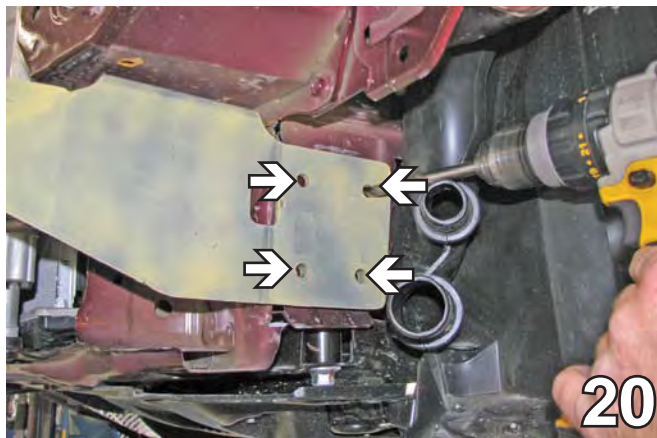

20. Using the baseplate as a template, drill the four round holes with the 13/32" extra long 6" drill bit. Do this on both sides of the vehicle.

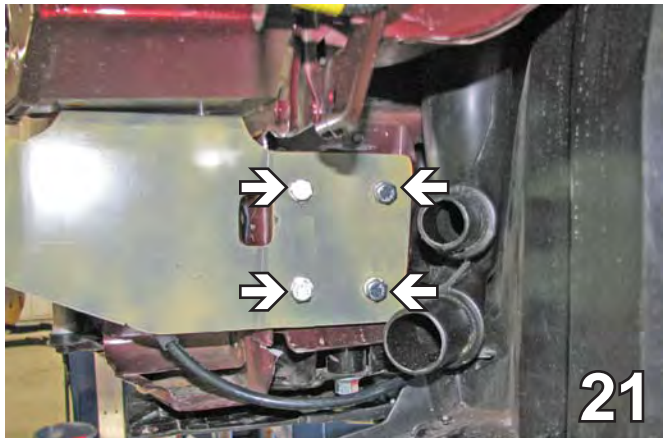

21. Insert 3/8-16 x 1 1/2" hex bolts and 3/8" lock washers. Tighten to 3/8" nut plates inserted through the drilled frame rail opening. Be sure to use Loctite Red on all the bolts. Do this to both sides of the vehicle.



22. Attach the permanent baseplate safety cables to the provided convenience link on the baseplate (white arrow). The photo above shows the recommended installation of the cables to the frame of vehicle (gray arrow). Additional options may interfere with the suggested mounting. In this case, secure the cables to a solid piece of the frame as described in the instructions included with the permanent baseplate safety cables. Be sure the safety cables do not rub against any hoses or moving parts. Do this on both sides of the vehicle.



BLUE OX®

BX2256

2012 Honda Civic (No Foglights)
Installation Instructions

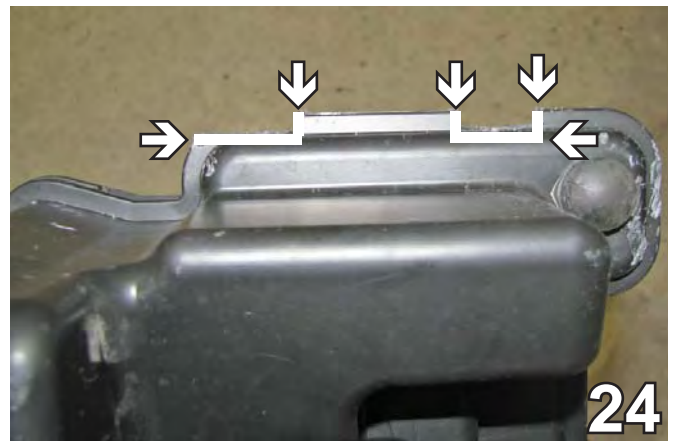
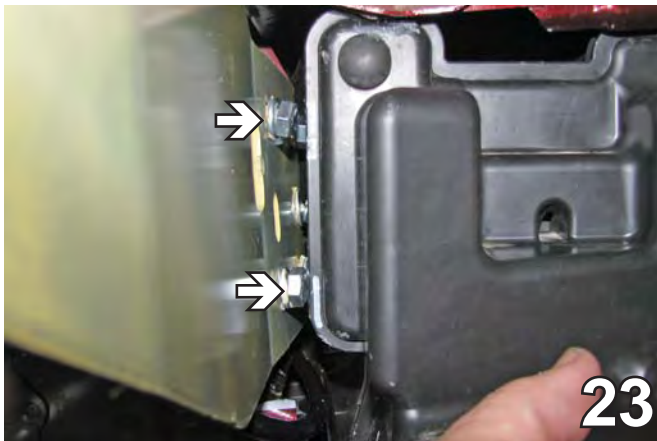

- 23. Align the air baffle to its original position on the driver side. Mark the areas which will need to be notched in air baffle webbing only to allow space for the baseplate bolts.
- 24. Using a utility knife, trim the necessary space as marked in step 23. **Do not cut into the main body of the air baffle.** Slide the air baffle back in place on the driver side, and reinstall using the existing bolt.



- 25. On the passenger side, align the windshield washer back to its original position and reinstall using the existing bolts.
- 26. Reinstall the bumper and styrofoam inserting all push pins, bolts and screws.

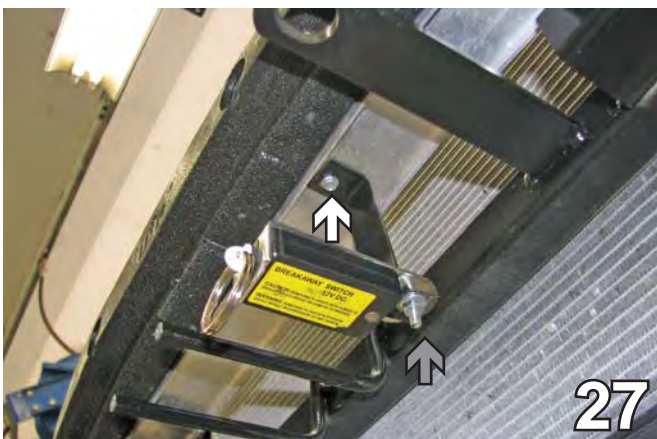

- 27. **Optional:** Position the breakaway bracket on the bottom side of the bumper centered between the electrical rod and the convenience link on the driver side. Fasten with a 10-16 x 1" self drilling screw (white arrow). Attach the breakaway to the bracket with a 1/4-20 x 3/4" hex bolt and 1/4-20 hex nut (gray arrow).



BLUE OX[®]

BX2256

2012 Honda Civic (No Foglights)
Installation Instructions



28. Reinstall the fascia. Attach the electrical bracket to the center of the fascia.

Install the tow bar and safety cables according to the instructions when demonstrating this to the customer. Be sure to include all the contents and packages.

Do **NOT** substitute other devices if the tow bar pins and clips are misplaced.

DEALER or INSTALLER:
Be certain the user receives the
instruction sheets for their products.

Be sure that **ALL** electrical connections
are plugged in properly and functioning
BEFORE installing the fascia.



BLUE OX®

BX2256

2012 Honda Civic (No Foglights) Installation Instructions



Shown with removable tabs installed



Shown without removable tabs installed

CUSTOMER SERVICE COMMITMENT

Blue Ox is committed to providing you with exceptional customer care throughout your lifetime with our products. Our team is here to assist you with any questions you may have regarding the performance of your product. Simply call (402) 385-3051 and you can speak with our customer care team.

Additionally, please visit our website to see which rallies our Destination America team will be attending. For a nominal fee, our service technician will service your towing system to ensure it's in proper working condition. Also, as a commitment to our customers, should you visit our factory, you can stay at our full service Blue Ox campground at no charge along with enjoying a factory tour.

Again, thank you for being our customer and for the confidence you have shown in the performance of our products. It is because of customers like you we enjoy the success we have today.

If the baseplate is in an accident, it must be replaced. DO NOT use it again! An accident can cause unseen damage and using it again could result in more damage or serious injury. DO NOT use the baseplate if it is damaged or missing parts.



BLUE OX®

© 2011 Blue Ox
One Mill Road, Industrial Park
Pender, Nebraska 68047
Phone: (402) 385-3051
Fax: (402) 385-3360
www.blueox.com