



# BX2260

## 2013 Honda Accord Sedan Installation Instructions

**Attachment Tab Height: 15"**

**Attachment Tab Width: 22"**

**Serial Number**

**Please read BOTH these Installation Instructions and the General Instructions prior to installing or operating this equipment.**

1. Blue Ox® towing products and accessories are intended to be installed by Blue Ox® Dealers who are familiar with our products and have the equipment and knowledge necessary to do "fit work". If needed, Blue Ox® Dealers can be found at [www.blueox.com](http://www.blueox.com) or by contacting our Customer Care Department at (402) 385-3051.
2. Many Blue Ox® baseplates are designed to use existing holes and hardware to mount the baseplate to the towed vehicle. Even though bolts are there, do not assume they are adequate for baseplate mounting. Always use the hardware supplied in the hardware kit and existing hardware as specified in the installation instructions.

### Bolt Torque Specifications

Torque in Foot-Pounds for Inch Bolts

Bolt Size	Grade 5	Grade 8
1/4"	10	14
5/16"	19	29
3/8"	33	47
7/16"	54	78
1/2"	78	119
5/8"	154	230
3/4"	257	380



If the front of your vehicle looks different than this, please contact us at (402)385-3051.

**Reference your vehicle owner's manual for manufacturer's towing specifications.**

### Bolt Torque Specifications

Torque in Foot-Pounds for Metric Bolts

Bolt Size	Grade 8.8	Grade 10.9
6MM	6	8
8MM	16	22
10MM	31	40
12MM	54	70
14MM	89	117
16MM	161	230
18MM	222	318



## WARNING

Failure to read and follow these instructions could result in separation of the towed vehicle from the tow bar, causing property damage, loss of towed vehicle, personal injury or death.

BX2260  
2013 Honda Accord Sedan  
Installation Instructions

**Instruction Notes:** The fascia, fascia cover, air baffle and windshield washer fluid reservoir are removed and reinstalled for the baseplate installation. Some drilling and trimming is required.

Place all components that are removed on a flat, sturdy surface. All items will be reinstalled unless otherwise noted after the baseplate is installed.

The dimensional variations between otherwise identical vehicles can be considerable. While the baseplate was designed for easy installation, it may be necessary to tailor the baseplate slightly to compensate for vehicle manufacturer's tolerances.

The BX8848 4-Diode Wiring Kit is recommended for this vehicle.

## ***NOTICE***

- Handling of some cosmetic parts when installing this product may require the use of protective covers, rags, specialty tools, etc. to prevent damage.
- When using power drills be aware of the dangers of torque and drill bit length.
- When using a reciprocating saw be aware of objects behind the cutting surface.
- Use a good quality paint to spray cut edges of frame to prevent rusting.
- Be sure that **ALL** electrical connections are plugged in and accessories are functioning properly before reinstalling the fascia.
- The baseplate is computer tested to your vehicle's GVWR, exceeding this weight will void the manufacturer's warranty.
- Be sure to use Loctite® Red on all bolts before tightening. Tighten all bolts according to the torque chart provided.
- Dealer or installer be certain the user receives these instruction sheet.
- If the baseplate is in an accident, it must be replaced. **DO NOT** use it again! An accident can cause unseen damage and using it again could result in more damage or serious injury. **DO NOT** use the baseplate if it is damaged or missing parts.

**BX2260**  
**2013 Honda Accord Sedan**  
**Installation Instructions**

**Tools Required**

Large Vise Grip  
 Utility Knife  
 Phillips Screwdriver  
 Torque Wrench  
 Drill  
 Reciprocating Saw  
 Tape Measure  
 Loctite® RED  
 13/32" Drill Bit  
 1-1/4" Hole Saw  
 10MM Socket  
 9/16" Socket  
 9/16" Wrench

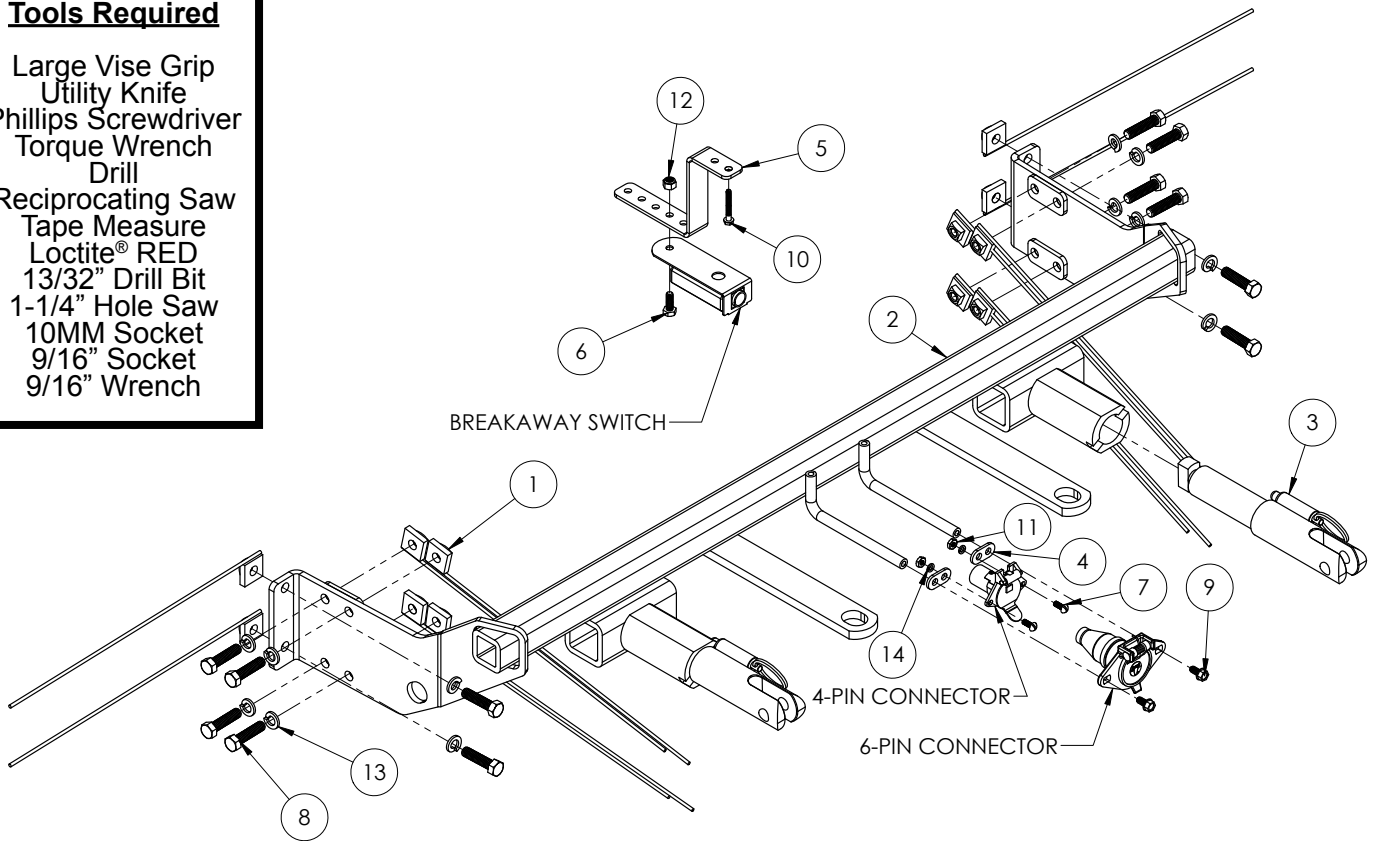

Item No.	Part No.	Description	Qty.
1	61-5208	3/8"-16 Nut Plate w/ 14" Wire	12
2	61-7256	BX2260 Baseplate	1
3	62-3469	Attachment Tab Assembly with Hole	2
4	101-5822	4 Way Connector Adapter	2
5	101-8324	Breakaway Bracket	1
6	201-0050	1/4"-20 x 3/4" Hex Head Bolt, Grade 5, ZP	1
7	201-0192	#10-32 1/2" Round Slotted Head Screw	2
8	201-0440	3/8"-16 x 1-1/2" Hex Head Bolt, Grade 5, ZP	12
9	201-0553	1/4-20 x 1/2" Hex Wshd Bolt Type F TCS, ZP	2
10	201-0654	#10-16 x 1" Self Drilling Screw, ZP	1
11	202-0047	#10-32 Hex Nut	2
12	202-0102	1/4"-20 Hex Nylon Nut, ZP	1
13	203-0010	3/8" Lock Washer, ZP	12
14	203-0054	#10 Lock Washer, ZP	2
15	226-0046(not shown)	Class III Safety Cables	2
16	229-0359(not shown)	3/8" Quicklink, ZP	2
17	290-0437(not shown)	Black Cap Plug Receiver	2

**Important:**

Use only genuine factory replacement parts on your baseplate. Do **NOT** substitute homemade or non-typical parts. If a bolt is lost or in need of replacement, for your safety and the preservation of your baseplate, be sure to use a replacement bolt of the same grade (In most cases it will be Grade 5, please reference the parts list above). Replacement parts may be ordered through your nearest Blue Ox® Dealer or Distributor. Failing to follow and/or altering these installation instructions in either installation or required equipment will void the manufacturer's warranty. Towing behind a non-motorized vehicle will void the warranty.

BX2260  
2013 Honda Accord Sedan  
Installation Instructions

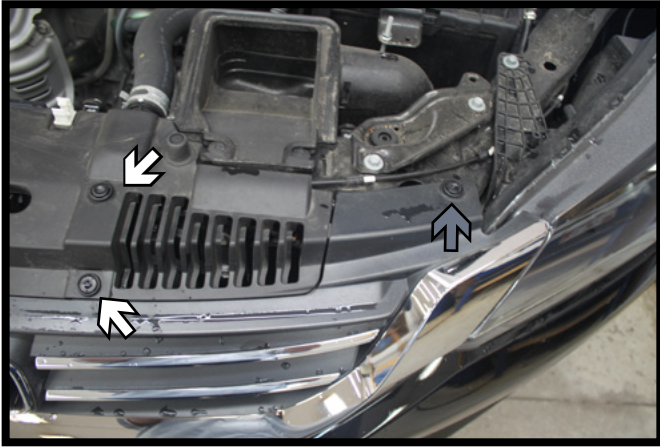

1. Remove the four (4) push pins from the fascia cover (white). There are two (2) on each side and set aside. Remove the two (2) push pins from the outer edges of the top of the fascia (gray). There is one (1) on each side.

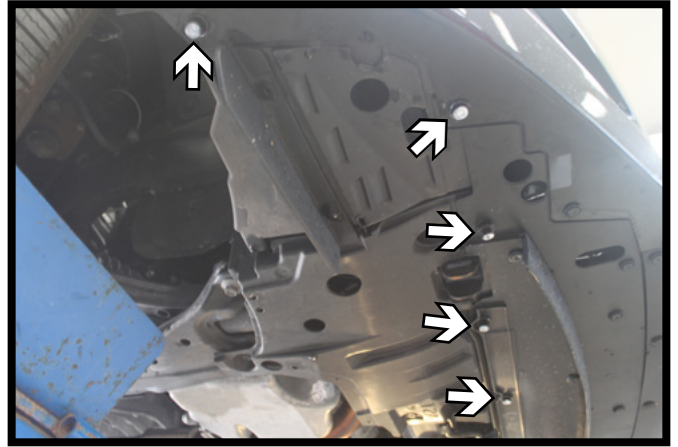

2. Remove the ten (10) push pins from the underside of the fascia. There are five (5) on each side.

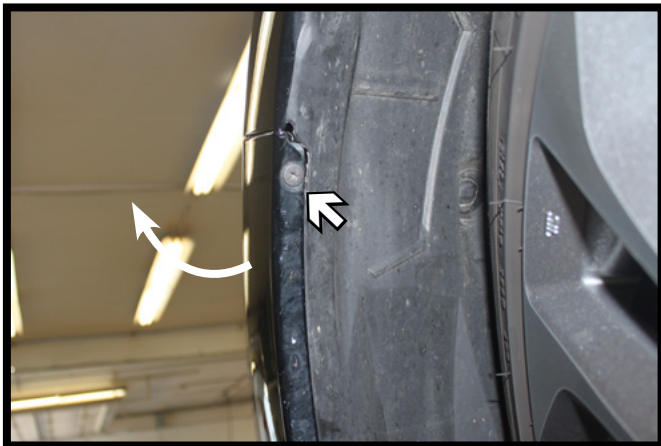

3. Using a Phillips screwdriver, remove the screw from the wheel well. Do this on both sides of the vehicle. Pull the corners of the fascia away from the vehicle and pull the fascia off the vehicle. Disconnect all electrical connections and set the fascia aside.

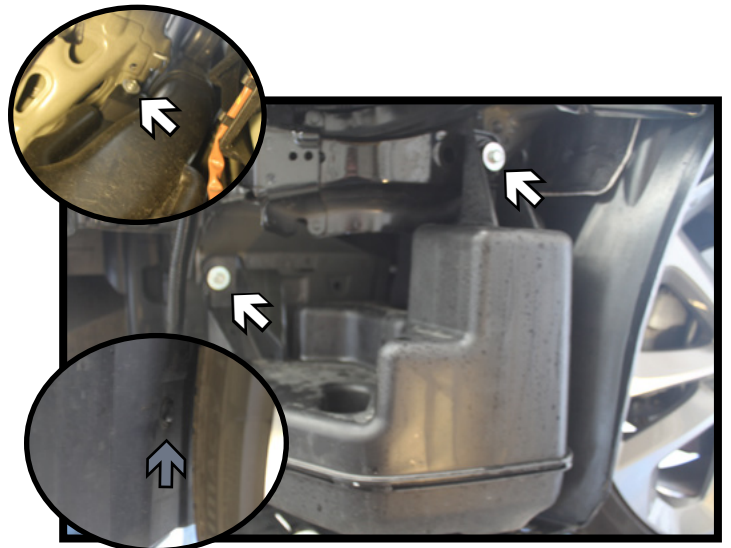

4. Using a 10MM socket, remove the three (3) screws from the air baffle. There are two (2) on the outside and one (1) on the inside of the frame (white). In the wheel well remove the push pin (gray) and set the baffle aside.

BX2260  
2013 Honda Accord Sedan  
Installation Instructions

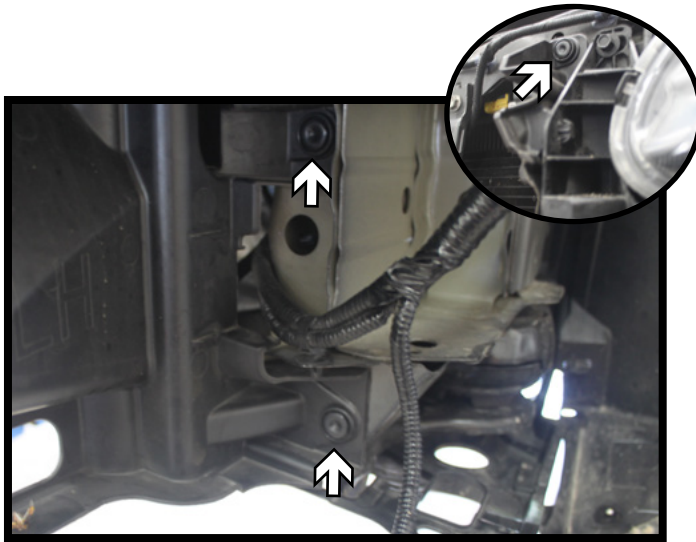

5. Remove the three (3) push pins from the shroud. There are two (2) on lower section and one (1) at the top. Unclip and remove the shroud, it will not be reinstalled. Do this on both sides of the vehicle.

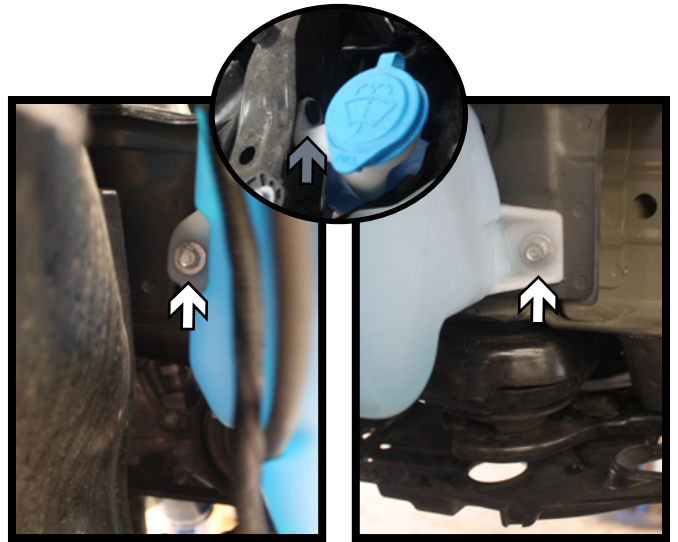

6. Using a 10MM socket, remove the two (2) screws from washer reservoir (white). Remove the push pin from the filler neck next to the cap (gray). Disconnect all lines from the reservoir and set aside.

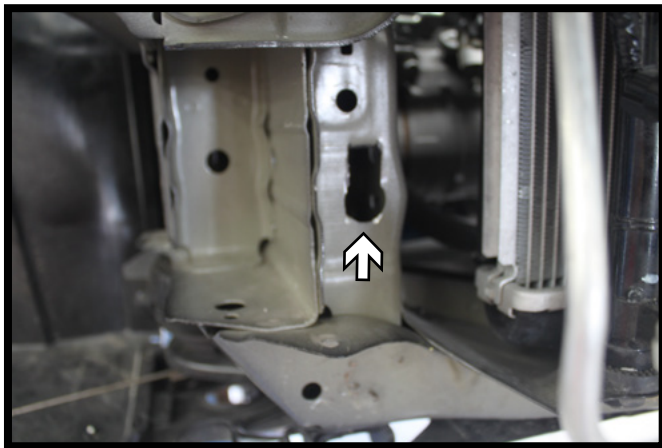

7. Using a reciprocating saw, cut two (2) slits vertically on the existing frame hole. Bend the tab inwards to allow nut plate access. Do this on both sides of the vehicle.

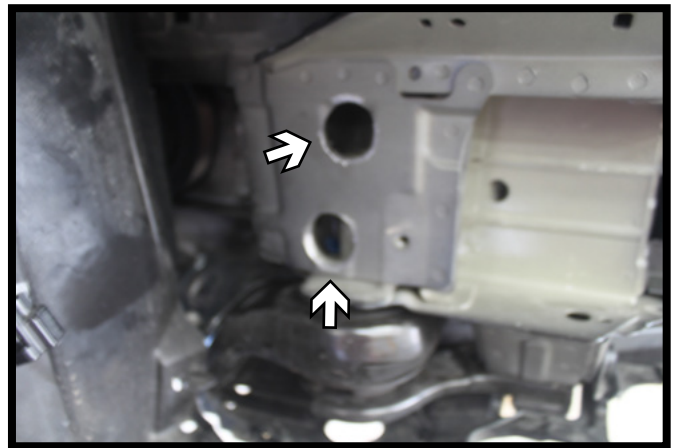

8. Using a 1-1/4" hole saw, drill two (2) access holes in the side of the frame as shown for nut plate access. Do this on both sides of the vehicle.

BX2260  
2013 Honda Accord Sedan  
Installation Instructions

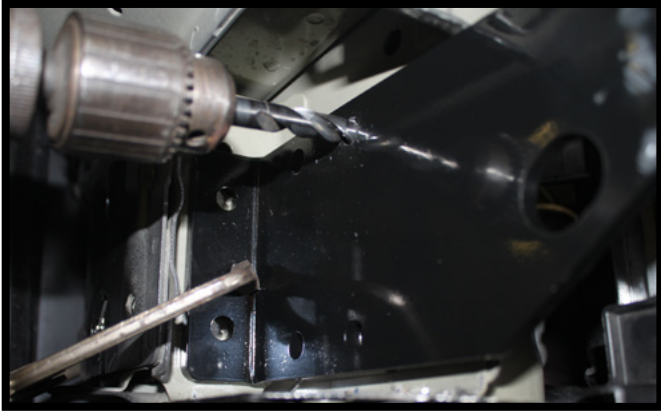

9. Position the baseplate onto the vehicle. Level and clamp the baseplate to the frame. Using a 13/32" drill bit, drill the front top hole in the baseplate thru the frame. Install a 3/8"-16 x 1-1/2" bolt with a 3/8" lock washer into the hole and secure with a 3/8" nut plate on the inside of the frame. Do this on both sides of the vehicle. Fully tighten both fasteners.



10. Continue to drill the remaining holes thru the frame. Install 3/8"-16 x 1-1/2" bolts with a 3/8" lock washers into the holes and secure with a 3/8" nut plates on the inside of the frame. Do this on both sides of the vehicle. Fully tighten all fasteners.

Note: On the back flanges, drill the hole thru the frame towards the top of the slots.



11. Attach the permanent baseplate safety cables to the provided convenience link on the baseplate. The photo above shows the recommended installation of the cables to frame of vehicle. Additional options may interfere with suggested mounting; in this case, secure the cables to a solid piece of the frame as described in the instructions included with the permanent baseplate safety cables. Be sure the safety cables do not rub against any hoses or moving parts. Do this on **BOTH** sides of the vehicle.



12. Reinstall the washer reservoir and air baffle.

Hold the fascia as close to its original position, mark and trim the fascia around the convenience links and attachment tabs. Reinstall the fascia and fascia cover.

BX2260  
2013 Honda Accord Sedan  
Installation Instructions

**CUSTOMER SERVICE COMMITMENT**

Blue Ox® is committed to providing you with exceptional customer care throughout your lifetime with our products. Our team is here to assist you with any questions you may have regarding the performance of your product. Simply call (402) 385-3051 and you can speak with our customer care team.

Additionally, please visit our website to see which rallies our Destination America team will be attending. For a nominal fee, our service technician will service your towing system to ensure it's in proper working condition. Also, as a commitment to our customers, should you visit our factory, you can stay at our full service Blue Ox® campground at no charge along with enjoying a factory tour.

Again, thank you for being our customer and for the confidence you have shown in the performance of our products. It is because of customers like you we enjoy the success we have today.

© 2013 Blue Ox  
One Mill Road, Industrial Park  
Pender, Nebraska 68047  
Phone: (402) 385-3051  
Fax: (402) 385-3360  
[www.blueox.com](http://www.blueox.com)