



BLUE OX

BX2331 2011-13 Hyundai Elantra (No Touring) Installation Instructions

Serial Number

Attachment Tab Height: 14-1/2"

Attachment Tab Width: 20"

Please read BOTH these Installation Instructions and the General Instructions prior to installing or operating this equipment.

- Blue Ox® towing products and accessories are intended to be installed by Blue Ox® Dealers who are familiar with our products and have the equipment and knowledge necessary to do "fit work". If needed, Blue Ox® Dealers can be found at www.blueox.com or by contacting our Customer Care Department at (402) 385-3051.
- Many Blue Ox® baseplates are designed to use existing holes and hardware to mount the baseplate to the towed vehicle. Even though bolts are there, do not assume they are adequate for baseplate mounting. Always use the hardware supplied in the hardware kit and existing hardware as specified in the installation instructions.



If the front of your vehicle looks different than this, please contact us at (402)385-3051.

Reference your vehicle owner's manual for manufacturer's towing specifications.

Bolt Torque Specifications
Torque in Foot-Pounds for Metric Bolts

Bolt Size	Grade 8.8	Grade 10.9
6MM	6	8
8MM	16	22
10MM	31	40
12MM	54	70
14MM	89	117

Bolt Torque Specifications
Torque in Foot-Pounds for Inch Bolts

Bolt Size	Grade 5	Grade 8
1/4"	10	14
5/16"	19	29
3/8"	33	47
7/16"	54	78
1/2"	78	119
5/8"	154	230

! WARNING

Failure to read and follow these instructions could result in separation of the towed vehicle from the tow bar, causing property damage, loss of towed vehicle, personal injury or death.

BX2331
2011-13 Hyundai Elantra (No Touring)
Installation Instructions

Vehicle Weight: Motorhome mount tow bars are recommended for use with this baseplate. Due to the design of the removable tabs, the RangeFinder II and Ambassador tow bars can not be used. Adapters, except the BX8833 and BX88151, can not be used with this baseplate.

Instruction Notes: The fascia, plastic cover, air baffle, bumper, horn and windshield washer fluid reservoir are removed and reinstalled for the baseplate installation. Some drilling and trimming is required.

Place all components that are removed on a flat, sturdy surface. All items will be reinstalled unless otherwise noted after the baseplate is installed.

The dimensional variations between otherwise identical vehicles can be considerable. While the baseplate was designed for easy installation, it may be necessary to tailor the baseplate slightly to compensate for vehicle manufacturer's tolerances.

The BX8848 Diode Tail Light Wiring Kit is recommended for this vehicle.

NOTICE

- Handling of some cosmetic parts when installing this product may require the use of protective covers, rags, specialty tools, etc. to prevent damage.
- When using power drills be aware of the dangers of torque and drill bit length.
- Be sure that **ALL** electrical connections are plugged in properly and functioning before reinstalling the fascia.
- Do not use the towed vehicle for storing luggage, equipment, etc. This may cause you to exceed the towing capacity of the tow bar, baseplate and its accessories.

BX2331

2011-13 Hyundai Elantra (No Touring)

Installation Instructions

Tools Required

Large Vise Grip
 Flat Screwdriver
 Utility Knife
 Phillips Screwdriver
 Torque Wrench
 Drill
 Reciprocating Saw
 Tape Measure
 Loctite® RED
 13/32" Drill Bit
 10MM Socket
 12MM Socket
 7/16" Socket
 9/16" Socket
 7/16" Wrench
 9/16" Wrench

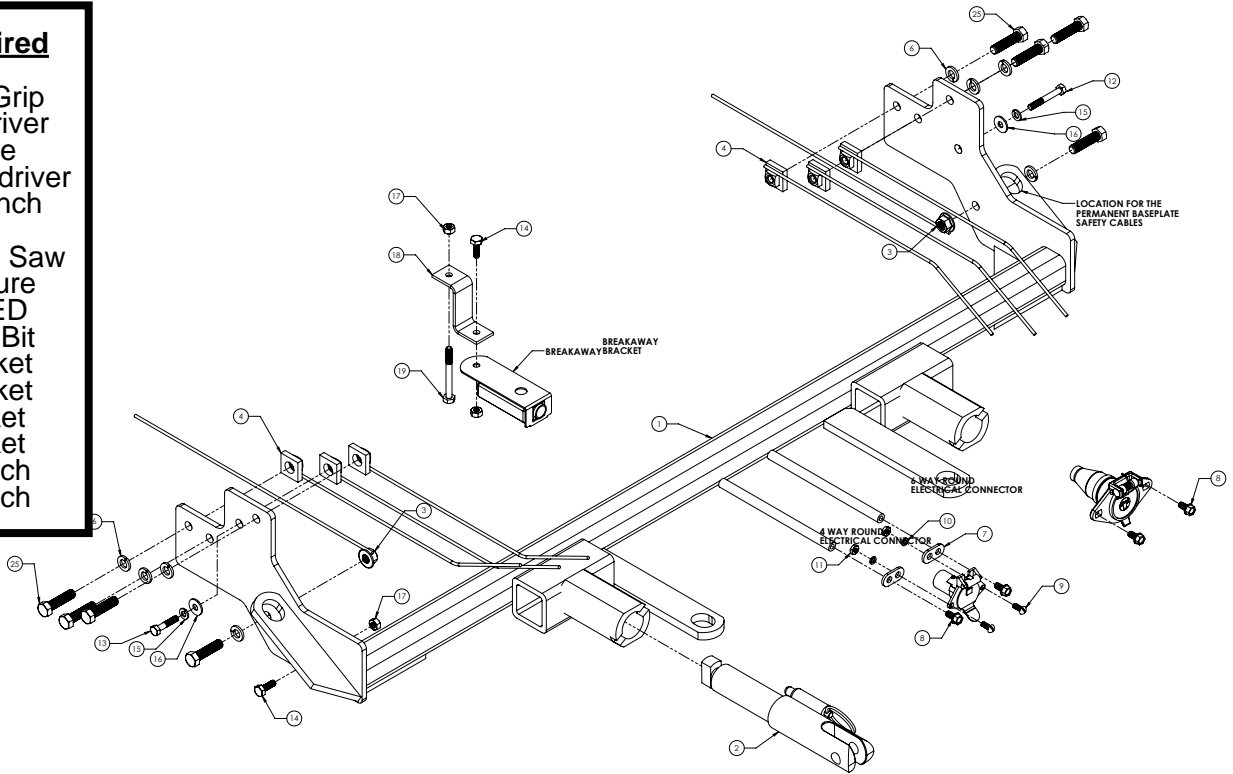

Item No.	Part No.	Description	Qty.
1	61-6856	BX2331 Baseplate	1
2	62-3469	Attachment Tab Assembly with Hole	2
3	61-4978	3/8"-16 Whiz Nut w/ 14" Wire	2
4	61-5208	3/8"-16 Nut Plate w/ 14" Wire	6
5	201-0440	3/8"-16 x 1-1/2" Hex Head Bolt, Grade 5, ZP	8
6	203-0010	3/8" Lock Washer, ZP	8
7	101-5822	4 Way Connector Adapter	2
8	201-0553	1/4-20 x 1/2" Hex Wshd Bolt Type F TCS, ZP	2
9	201-0192	#10-32 x 1/2" Round Slotted Head Screw	2
10	203-0054	#10 Lock Washer, ZP	2
11	202-0047	#10-32 Hex Nut	2
12	201-0702	6MM-1.0 x 45MM Hex Head Bolt, Grade 8.8, ZP	1
13	201-0655	6MM-1.0 x 30MM Hex Head Bolt, Grade 8.8, ZP	1
14	201-0050	1/4"-20 x 3/4" Hex Head Bolt, Grade 5, ZP	2
15	203-0008	1/4" Lock Washer, ZP	2
16	203-0001	1/4" Flat Washer, ZP	2
17	202-0102	1/4"-20 Hex Nylon Nut, ZP	3
18	102-7056	BX2331 Breakaway Bracket	1
19	201-0321	1/4"-20 x 2-1/2" Hex head Bolt, Grade 5, ZP	1
20	226-0046(not shown)	Class III Safety Cables	2
21	229-0359(not shown)	3/8" Quicklink, ZP	2
22	290-0437(not shown)	Black Cap Plug Receiver	2

Important:

Use only genuine factory replacement parts on your baseplate. Do **NOT** substitute homemade or non-typical parts. If a bolt is lost or in need of replacement, for your safety and the preservation of your baseplate, be sure to use a replacement bolt of the same grade (In most cases it will be Grade 5, please reference the parts list above). Replacement parts may be ordered through your nearest Blue Ox® Dealer or Distributor. Failing to follow and/or altering these installation instructions in either installation or required equipment will void the manufacturer's warranty.

BX2331
2011-13 Hyundai Elantra (No Touring)
Installation Instructions



1. On the driver side using a Phillips screwdriver, remove three push pins from the top of the fascia. Set pins aside to be reinstalled later.



2. On the passenger side using a Phillips screwdriver, remove two push pins from the top of the fascia. Set pins aside to be reinstalled later.

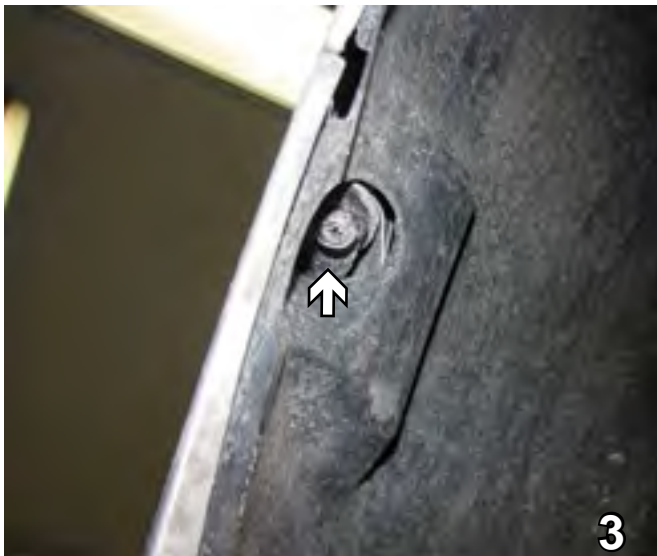

3. Using a 10MM socket, remove the metric bolt from in front of the tire. Do this to both sides of the vehicle. Set bolts aside to be reinstalled later.



4. Using a Phillips screwdriver, remove three plastic Phillips pushpins from just forward of the front tire along the bottom edge of fascia. The fascia is then ready to be removed from the vehicle by pulling fascia ends out to the side to release and then pulling it forward. Do this to both sides of the vehicle. Set fascia and pushpins aside to be reinstalled later.

BX2331
2011-13 Hyundai Elantra (No Touring)
Installation Instructions



5. On the passenger side, unplug the hoses from the windshield washer reservoir and cap (gray arrows). Using a 10MM socket, remove the bolt on the side (white arrow). Set the bolt aside to be reinstalled later.

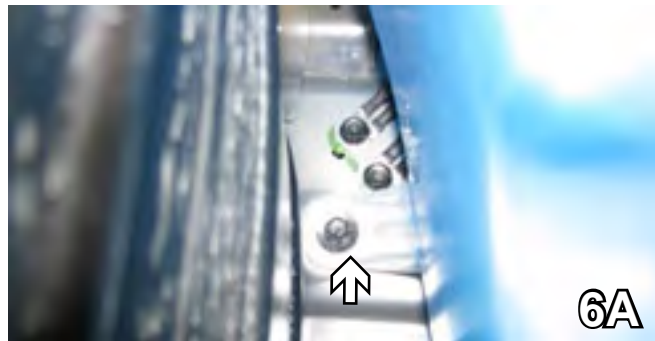

6. Using a 10MM socket, remove the metric bolt in the back (6A). Using a Phillips screwdriver loosen the screw on the top (6B). Set washer reservoir and bolts aside to be reinstalled later.



7. Using a 10MM socket, remove two bolts underneath on the side of the back plastic cover. Do this on both sides of the vehicle. Set bolts aside to be reinstalled later.



8. Using a 10MM socket, remove three bolts underneath across the front of the back plastic cover. One bolt on each side and one in the middle. Set bolts and plastic aside to be reinstalled later.

BX2331
2011-13 Hyundai Elantra (No Touring)
Installation Instructions

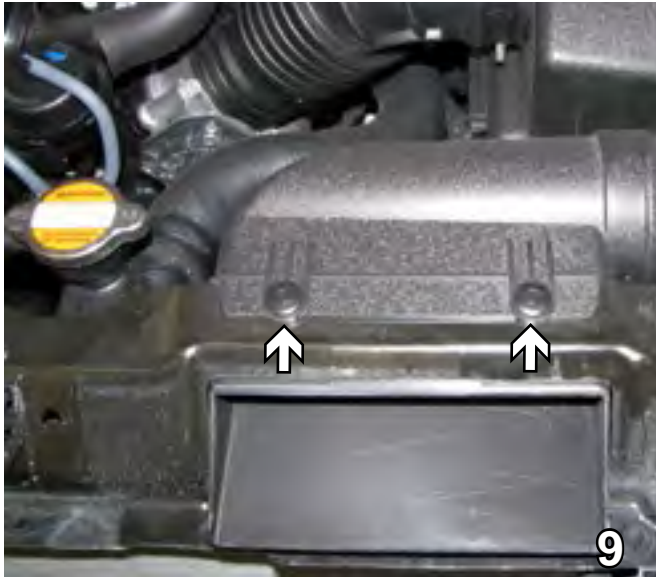

9. On the top front of the car, remove the two push pins before the air baffle can be removed. Push in on each push pin and it will release and pop out. Set the cover and the pins aside to be reinstalled later.



10. On the driver side, using a 10MM socket remove one bolt on the outside of the air baffle.



11. On the driver side, using a 10MM socket, remove the bolt from the back side of the air baffle. Set the bolt aside to be reinstalled later.



12. On the driver side underneath the vehicle, using a 10MM socket remove the bolt. Set the air baffle and the bolt aside to be reinstalled later.

BX2331
2011-13 Hyundai Elantra (No Touring)
Installation Instructions

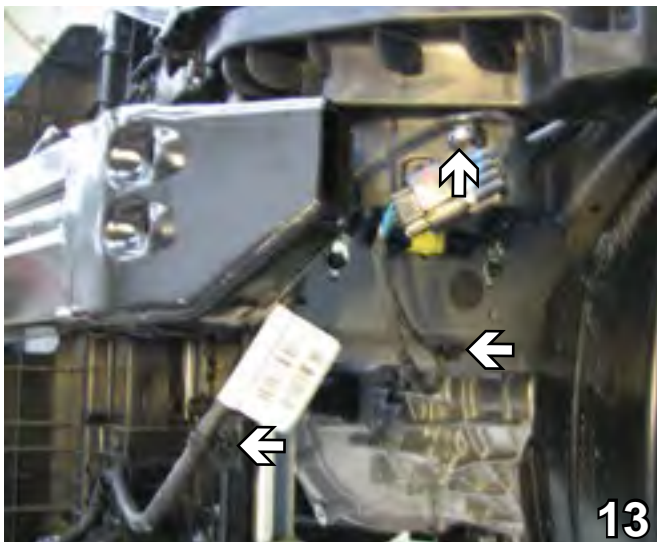

13. On the driver side, unplug the three pins holding the cable and move it out of the way. It will be reattached later.



14. On the driver side, using a 10MM socket remove the ground wires from the left side and reattach them with the ground wires on the right side.

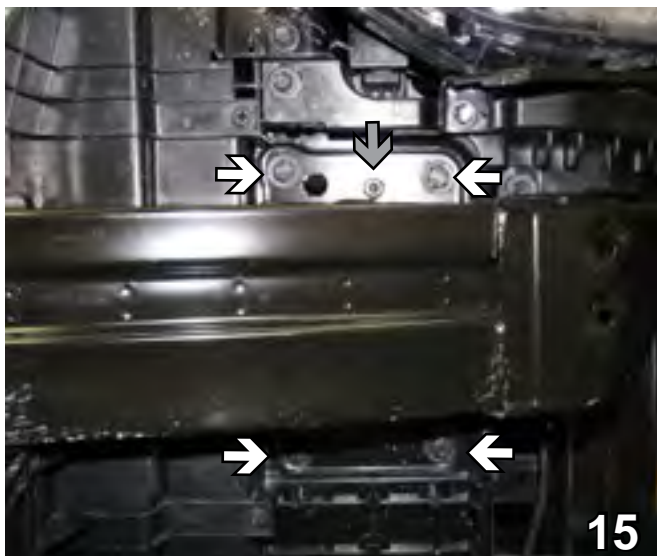

15. Using a 12MM socket, remove the two bolts (white arrows) above and below the bumper. Using a 10MM socket, remove one bolt (gray arrow) in the middle above the bumper. Do this to both sides of the vehicle.



16. Using the 10MM socket, remove the bolt attaching the horn to the bracket (white arrow). Unplug the horn (gray arrow). Set the horn and the bolt aside to be reinstalled later.

BX2331
2011-13 Hyundai Elantra (No Touring)
Installation Instructions

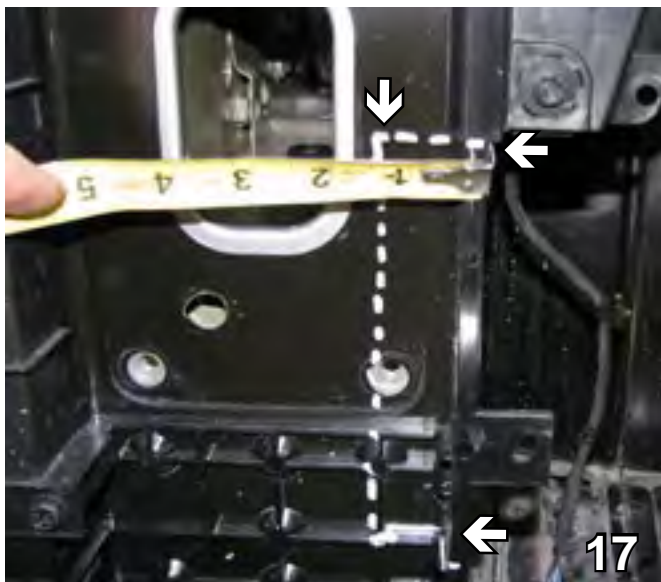

17. Using a reciprocating saw, trim out area below bumper. Measure just below metal bumper, in 1 1/2" from the side flush with the frame and straight down to the top of the second ridge. Remove this area from both sides.

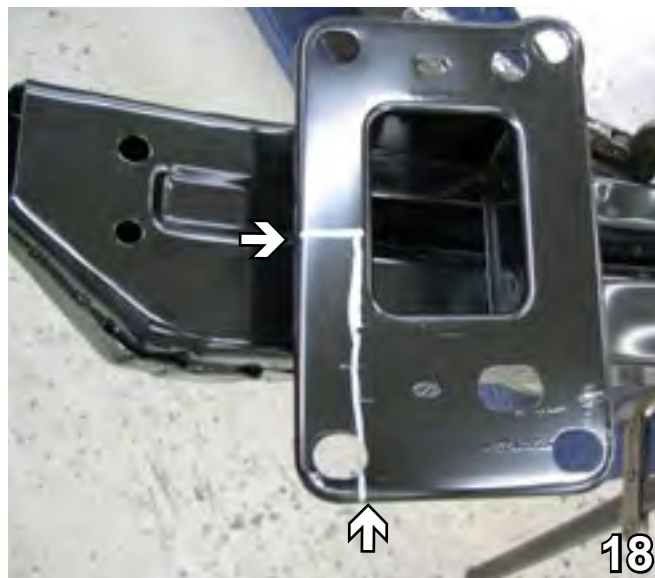

18. Put the bumper back on and mark on the backside of the bumper the area which was just removed. Using a reciprocating saw, trim out that area also. Do this to both sides of the bumper.



19. On the passenger side, cut the plastic 5" straight down and across along the ridge.

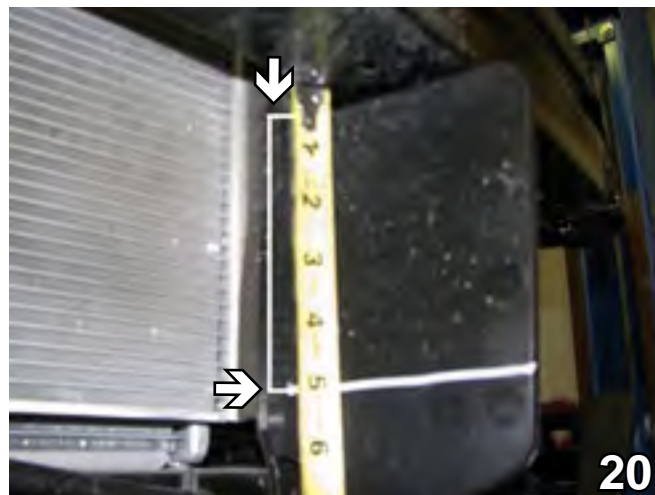

20. On the driver side, cut to the corner then 5" straight down to the bottom of the bumper and across.

BX2331
2011-13 Hyundai Elantra (No Touring)
Installation Instructions



21. Cut the horn bracket off of the bumper on the passenger side. It will be reinstalled in a different location.

Baseplate painted yellow for illustration.
Actual baseplate will be powder-coat black.

23. On the passenger side, start a bolt in the existing hole for the washer reservoir (gray arrow). Be sure the baseplate is level with respect to the vehicle frame. Tighten the bolt. Using the baseplate as a template with the 13/32" drill bit, drill the other four holes (white arrows). Do this on both sides.



22. Slide the baseplate up so it aligns with the existing hole on the driver's side. Clamp into place with the large vise grips.

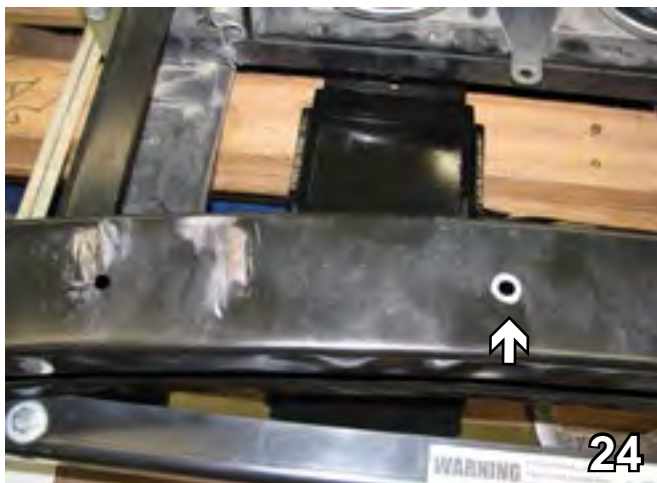
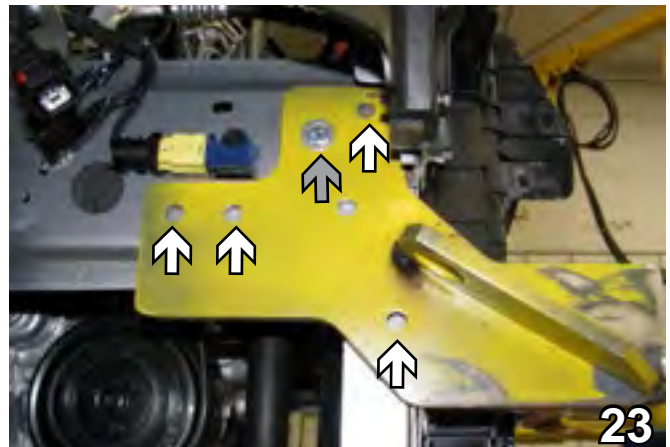

24. On the bottom of the bumper using a 13/32" drill bit, drill out the existing hole on the passenger side all the way through. This hole will be used later on for the breakaway bracket installation.

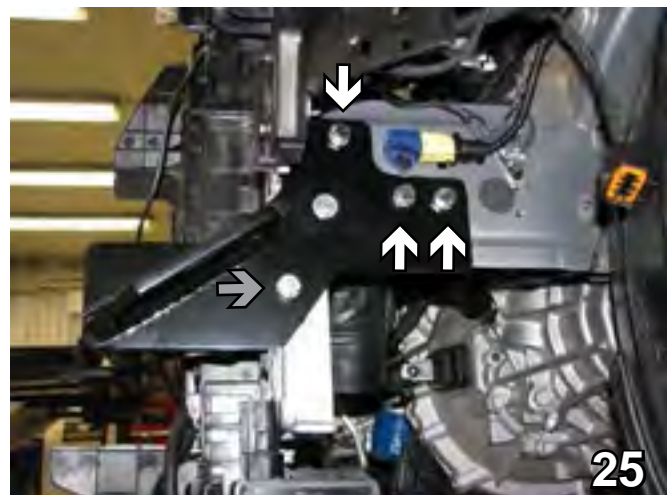

25. All four bolts are 3/8-16 x 1 1/2" and 3/8" lock washers. The top three are attached to 1" nut plates inserted into the bumper opening. The bottom one is attached to a 3/8-16 whiz nut inserted from underneath. Use Loctite Red on all bolts. Do this on both sides.

BX2331
2011-13 Hyundai Elantra (No Touring)
Installation Instructions



26. On the passenger side, mount the horn on the bottom hole with a 1/4-20 x 3/4" hex bolt to a 1/4-20 hex nut (white arrow) . Reconnect the plug (gray arrow).



27. Reinstall the air baffle with a 6MM-1 x 45MM hex bolt, 1/4" lock washer and 1/4" flat washer on the outside. Reattach the other bolts.



28. Reinstall the washer reservoir with a 6MM-1 x 30MM hex bolt, 1/4" lock washer and 1/4" flat washer into the existing hole on the baseplate. Use the existing bolts previously removed to tighten the other side. Reconnect the hoses.



29. Using a 13/32" drill bit, drill through the existing hole in the bottom of the bumper. Attach the breakaway bracket with a 1/4-20 x 2 1/2" hex bolt and 1/4-20 hex nut. Attach the breakaway to the bracket with 1/4-20 x 3/4" hex bolt and 1/4-20 hex nut.

BX2331
2011-13 Hyundai Elantra (No Touring)
Installation Instructions



30. Attach the permanent baseplate safety cables to the provided convenience link on the baseplate (see grey arrow). The photo above shows the recommended installation of the cables to frame of vehicle (see white arrow). Additional options may interfere with suggested mounting; in this case secure the cables to a solid piece of the frame as described in the instructions included with the permanent baseplate safety cables. Be sure the safety cables do not rub against any hoses or moving parts. Do this to both sides of the vehicle.



31. Reinstall the bumper and plastic cover. Trim the fascia as needed to clear the baseplate attachment tabs then reinstall. Reconnect the cables and the electrical plugs.

Install the tow bar and safety cables according to the instructions provided in their packages. When demonstrating this to the customer, be sure to include all the contents and packages.

Do **NOT** substitute other devices if the tow bar pins and clips are misplaced.

If the baseplate is in an accident, it must be replaced. DO NOT use it again! An accident can cause unseen damage and using it again could result in more damage or serious injury. DO NOT use the baseplate if it is damaged or missing parts.

BX2331
2011-13 Hyundai Elantra (No Touring)
Installation Instructions



Shown without removable tabs installed.



Shown with removable tabs installed.

CUSTOMER SERVICE COMMITMENT

Blue Ox® is committed to providing you with exceptional customer care throughout your lifetime with our products. Our team is here to assist you with any questions you may have regarding the performance of your product. Simply call (402) 385-3051 and you can speak with our customer care team.

Additionally, please visit our website to see which rallies our Destination America team will be attending. For a nominal fee, our service technician will service your towing system to ensure it's in proper working condition. Also, as a commitment to our customers, should you visit our factory, you can stay at our full service Blue Ox® campground at no charge along with enjoying a factory tour.

Again, thank you for being our customer and for the confidence you have shown in the performance of our products. It is because of customers like you we enjoy the success we have today.

© 2012 Blue Ox
One Mill Road, Industrial Park
Pender, Nebraska 68047
Phone: (402) 385-3051
Fax: (402) 385-3360
www.blueox.com