



**BX1507 Installation Instructions
2001-03 Buick Park Avenue**

Serial No.

The front fascia and metal bumper is removed for baseplate installation. Holes need to be drilled. The BX8869 is available for the vehicle. The attachment tabs are 24" center to center and at 12 1/4" height.



1. Remove 10 push pins from under front end just behind bumper.



2. There are two phillips screws just forward of front tires both sides .



3. Using the 10MM socket remove the two metric bolts from the inside of wheel well to separate fascia from fender.



4. Remove four metric bolts with 13MM socket from metal bumper and set metal bumper aside.



5. Remove bolt bracket with a 16MM socket and discard bracket.



6. Hold baseplate to align with these two existing holes and insert items 2,4, 5, and 6 both sides. **Be sure and use loctite on all bolts before tightening.**



7. Using the baseplate as a template drill 13/32" hole. Insert items 2, 5, and 6 according to drawing on last page.



8. Drill a 13/32" holes using the lower bracket as a template on both sides. Insert items 3, 5, and 6 according to drawing on last page. **Be sure and use loctite on all bolts before tightening.**

9. Reinstall metal bumper and fascia assuring that all bolt are tightened according to manufactor specifications.

10. The dimensional variations between otherwise identical cars can be considerable. While the location and size of the holes in the baseplate were designed to allow for easy installation, it may be necessary to file a hole slightly to allow a bolt to clear.

11. Install the tow bar and safety cables according to the instructions included in their packages.

12. Do **not** substitute other devices if the tow bar pin and clip are lost.

13. **DEALER OR INSTALLER: BE CERTAIN THE USER RECEIVES THE INSTRUCTION SHEET.**

Tools Required

10MM Socket
13MM Socket

16MM Socket

Loctite Blue
9/16" Socket

Phillips Screw Driver

13/32" Drill Bit
Vise Grips



Parts List

| Ref. No. | Qty. | Part No. | Description |
|----------|------|----------|-------------------------------------|
| 1 | 1 | 61-5660 | Weldment, Base Plate, BX1507 |
| 2 | 6 | 201-0440 | 3/8-16 x 1 1/2 Hex Bolt, Grd. 5, ZP |
| 3 | 2 | 201-0368 | 3/8-16 x 1 1/4 Hex Bolt, Grd. 5, ZP |
| 4 | 2 | 203-0003 | 3/8 Flat Washer, ZP |
| 5 | 6 | 203-0010 | 3/8 Lock Washer, ZP |
| 6 | 8 | 202-0003 | 3/8-16 Hex Nut, ZP |
| 7 | 2 | 201-0553 | 1/4-20 x 1/2 Hx. Wshd, Type F Screw |
| 8 | 2 | 202-0047 | #10-32 Hex Nut |
| 9 | 2 | 203-0054 | #10 Lock Washer |
| 10 | 2 | 201-0192 | #10-32 x 1/2 Slot, Rd. Hd. Screw |
| 11 | 2 | 101-5822 | Adapter, 4 Way Connector |

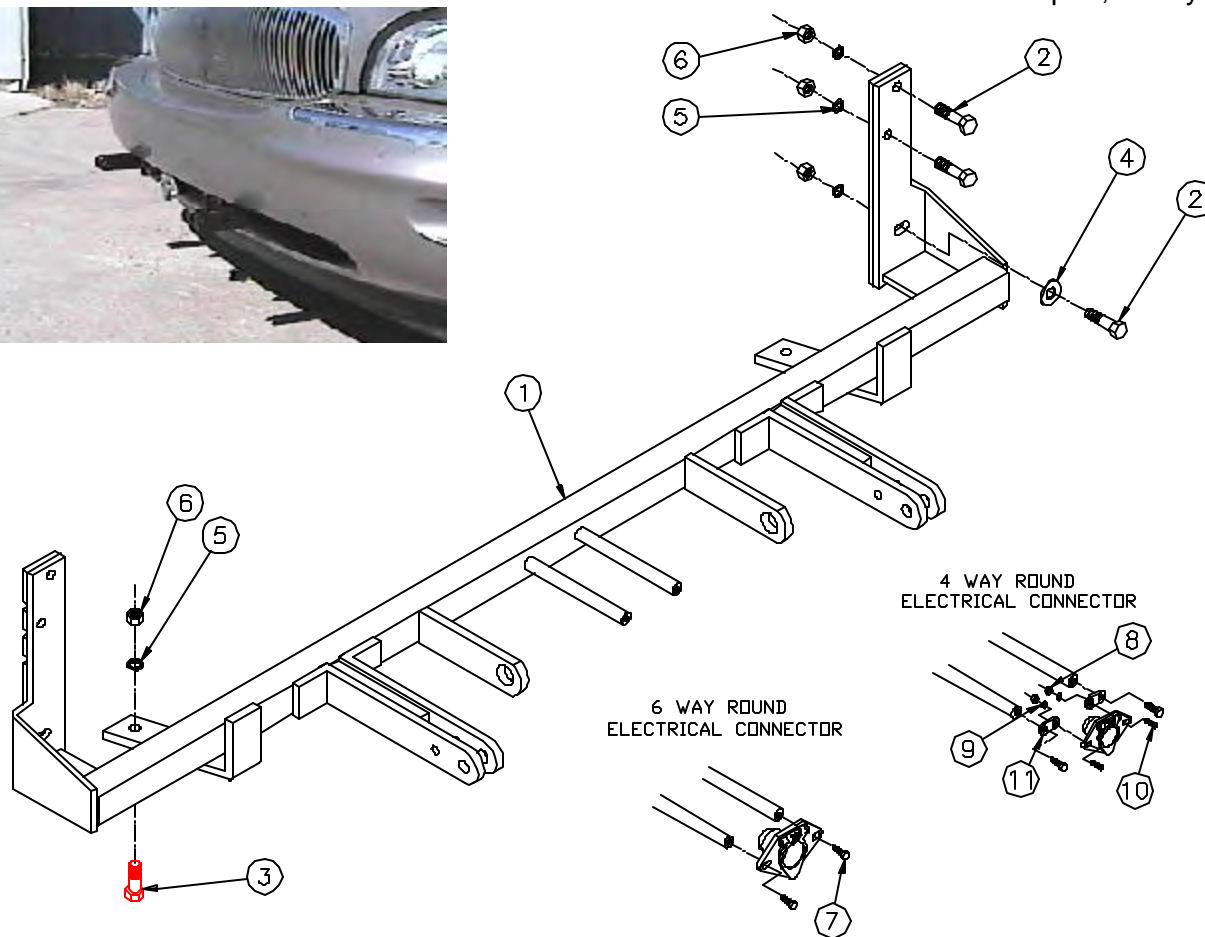

IMPORTANT: Use only genuine factory replacement parts on your Base Plate. Do not substitute homemade or nontypical parts. If a bolt is lost or in need of replacement, for your safety and the preservation of your Base Plate, be sure to use a replacement bolt of the same grade (Usually Grade 5, refer to parts list). Repair parts may be ordered through your nearest **Blue Ox** dealer or distributor.