



BX2161 Installation Instructions
1997-01 Ford E-150 Van
V-6 4.2L.

Serial No.

The front bumper is removed for baseplate installation. Holes need to be drilled. The attachment tabs are 24 inches center to center and 17 1/2 inches height. Model Notes: 1 and 38.



1. Remove two push pins from belly pan and set aside.



2. Using the 10MM socket, loosen the metric bolt on the horn bracket. Rotate horn bracket to center of vehicle and tighten metric bolt.



3. There are four metric bolts to remove on the metal bumper, using a 21MM socket. Set metal bumper aside.



4. There are two small existing holes on the bottom of the frame ends. Using the 17/32" drill bit, drill out the back hole.



Strong As An Ox™



5. Hold item 1 to align with back drilled hole. Insert items 3 and 4 into drilled hole, Item 2 into frame end, and tighten. **Be sure and use loctite on all bolts before tightening.**



6. Using the base plate as a template, drill the remaining hole, with the 17/32" drill bit, on frame bottom, each side. Install items 2, 3, and 4 into place, refer to drawing on last page. **Be sure and use loctite on all bolts before tightening.**



7. Drill the remaining holes on the inside of frame with the 17/32". Install items 2, 3, and 4 according to drawing on last page. **Be sure and use loctite on all bolts before tightening.**
8. Replace metal bumper and rotate horn bracket back to its original position.
9. The dimensional variations between otherwise identical cars can be considerable. While the location and size of the holes in the baseplate were designed to allow for easy installation, it may be necessary to file a hole slightly to allow a bolt to clear.
10. Install the tow bar and safety cables according to the instructions included in their packages.

11. Do **not** substitute other devices if the tow bar pin and clip are lost.

12. DEALER OR INSTALLER: BE CERTAIN THE USER RECEIVES THE INSTRUCTION SHEET.



Tools Required

21MM Socket
10MM Socket

Loctite Blue
3/4" Wrench

17/32" Drill Bit
Vise Grips

Parts List

Ref. No.	Qty.	Part No.	Description
1	1	61-5626	Weldment, Base Plate, BX2161
2	6	61-4029	Weldment, 1/2-13, Whiz Nut with Wire
3	6	201-0051	1/2-13 x 1 1/2 Hex Bolt, Grd. 5, ZP
4	6	203-0012	1/2 Lock Washer, ZP
5	2	201-0553	1/4-20 x 1/2 Hx. Wshd, Type F Screw
6	2	202-0047	#10-32 Hex Nut
7	2	203-0054	#10 Lock Washer
8	2	201-0192	#10-32 x 1/2 Slot, Rd. Hd. Screw
9	2	101-5822	Adapter, 4 Way Connector

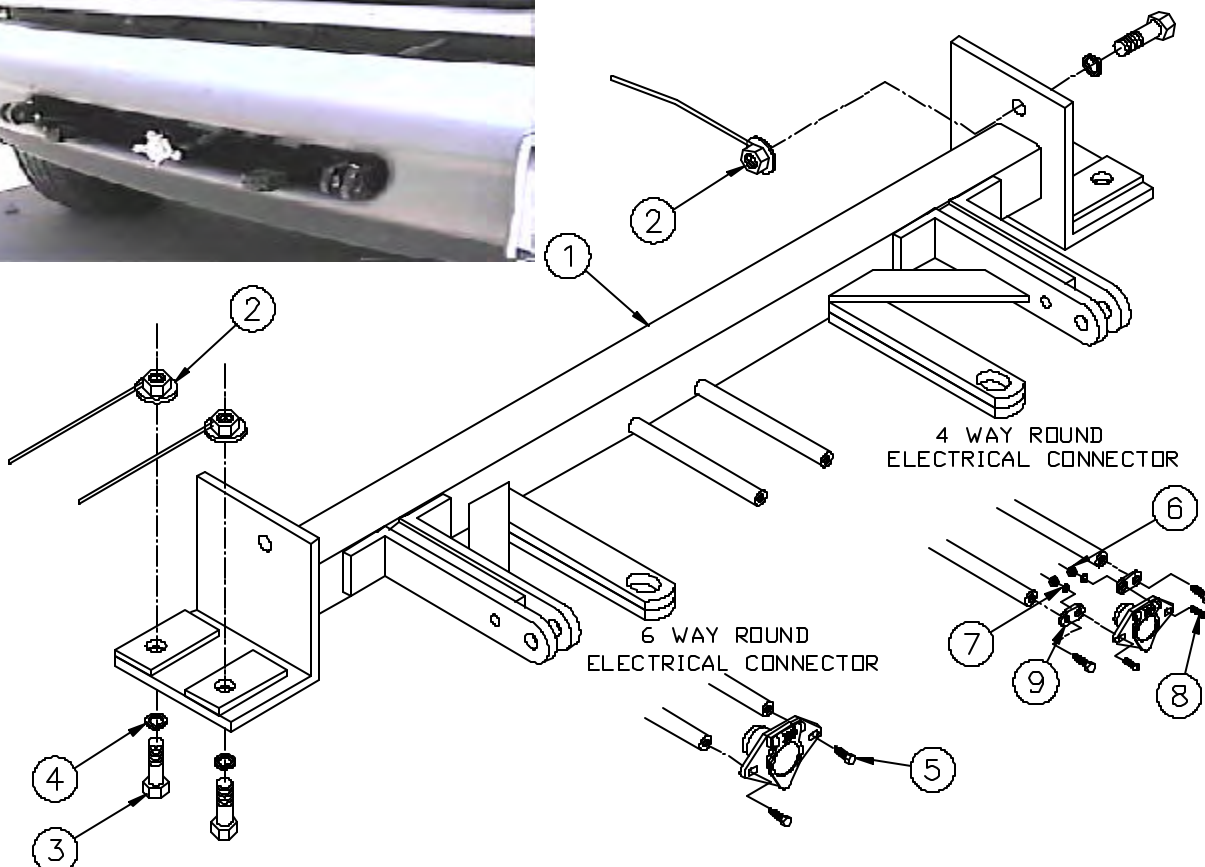
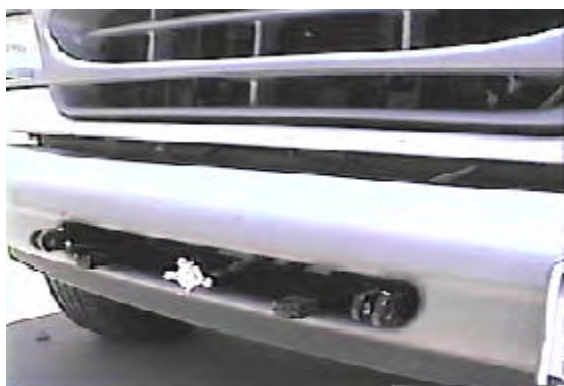

IMPORTANT: Use only genuine factory replacement parts on your Base Plate. Do not substitute homemade or nontypical parts. If a bolt is lost or in need of replacement, for your safety and the preservation of your Base Plate, be sure to use a replacement bolt of the same grade (Usually Grade 5, refer to parts list). Repair parts may be ordered through your nearest **Blue Ox** dealer or distributor.