



BX2312 Installation Instructions

Serial No.

2001 Hyundai Accent GL

1.6L DOHC 16Valve

The front fascia, window washer reservoir, and head light assembly is removed for baseplate installation. There are two factory fascia support brackets that will not be reinstalled. Holes need to be drilled and there is no trimming of fascia. The attachment tabs are centered at 24 inches and at 13 1/2 inches height.



1. Using the 10MM socket remove two metric bolts on head light assemblies, pull forward, unplug electrical connection, and set aside.



2. Remove phillips push pin from top side of fascia and one just under head light assembly location.



3. Just in front of tire pull wheel well sheild away from fascia corner and remove one phillips screw, each side.



4. Remove the six phillips screw push pins from the under side of the fascia.



5. Drain window washer reservoir and remove the metric bolt with the 10 MM socket from the top of reservoir.



6. Remove the two metric bolts from the each side of the reservoir and set aside.



Strong As An Ox™



7. Using the 10MM socket remove fascia support bracket from metal bumper, both sides. Fascia support bracket will not be reinstalled.



9. Have one person hold item 1 while you install items 3, 4, and 5 on drivers side, according to the drawing on last page, do not tighten. Repeat for passenger side and tighten all bolts **Be sure and use loctite on all bolts before tightening.**



8. Remove the three metric bolts from the tie down bracket with 17MM socket, each side. Tie down bracket will not be reinstalled.



10. Using the baseplate as a template drill the three remaining holes with the 13/32" drill bit. Insert item 2 into cross member openings to align with drilled holes. Tighten items 6 and 7 into place. **Be sure and use loctite on all bolts before tightening.**

10. To reinstall window washer reservoir it will be necessary to shim the bottom front bolt with item 13, to acquire proper fit.

11. Reinstall fascia and head light assemblies making sure all electrical connections are established.

12. The dimensional variations between otherwise identical cars can be considerable. While the location and size of the holes in the baseplate were designed to allow for easy installation, it may be necessary to file a hole slightly to allow a bolt to clear.

13. Install the tow bar and safety cables according to the instructions included in their packages.

14. Do **not** substitute other devices if the tow bar pin and clip are lost.

- 15. DEALER OR INSTALLER: BE CERTAIN THE USER RECEIVES THE INSTRUCTION SHEET.**



Tools Required

17MM Wrench
10MM Wrench
Phillip Screw Driver

Loctite Blue
9/16" Wrench

13/32" Drill Bit
Vise Grips

Parts List

Ref. No.	Qty.	Part No.	Description
1	1	61-5622	Weldment, Base Plate, BX2312
2	3	61-5208	Weldment, 3/8-16, Nut Plate, with Wire
3	6	101-6155	Spacer Plate, Bx2312
4	6	201-0595	12MM-1.25 x 60MM, Hex Bolt, Grd. 8.8, ZP
5	6	203-0105	12MM Lock Washer, ZP
6	3	201-0368	3/8-16 x 1 1/4 Hex Bolt, Grd. 5, ZP
7	3	203-0010	3/8 Lock Washer, ZP
8	2	201-0553	1/4-20 x 1/2 Hex Wshd., Type R, TCS
9	4	201-0192	#10-32 x 1/2 Slot, Rd. Hd. Screw
10	4	203-0054	#10 Lock Washer
11	4	202-0047	#10-32 Hex Nut
12	2	101-5822	Adapter, 4 Way Connector
13	4	203-0003	3/8 Flat Washer, ZP (Not Shown)

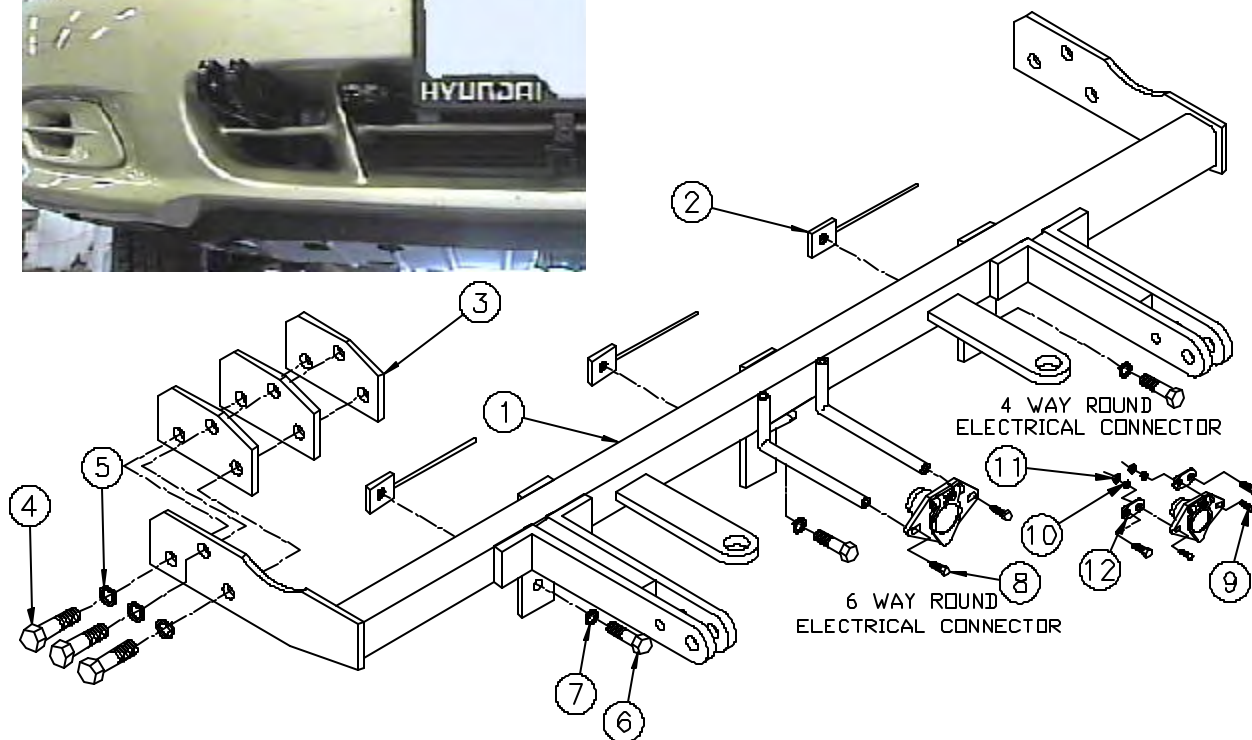

IMPORTANT: Use only genuine factory replacement parts on your Base Plate. Do not substitute homemade or nontypical parts. If a bolt is lost or in need of replacement, for your safety and the preservation of your Base Plate, be sure to use a replacement bolt of the same grade (Usually Grade 5, refer to parts list). Repair parts may be ordered through your nearest **Blue Ox** dealer or distributor.