



Strong As An Ox™

BX1302 Installation Instructions 2001 BMW 330Ci

Serial No.

The front fascia and air dam are removed for baseplate installation. Drilling is necessary. The BX8869 is available for the vehicle. Attachment Tabs are 20 inches center to center and a height of 15 inches.



1. Just forward of front tires, in wheel well, are three metric bolts to remove with the 8MM socket, both sides.



2. Using the 50 torx, remove two metric bolts on fascia just below head lights, both sides. Remove two push pins, both sides.



3. Remove four metric bolts with the 7MM socket and three push pins on the bottom side of the fascia.



4. Remove two phillips screws from outer belly pan with the phillips screw driver, both sides, pull fascia forward and set aside.



5. Measure the distance between the bumper brackets, to assure proper reinstallation. Remove three metric nuts from bumper brackets and drill out pop rivets, pull forward and set aside. Remove horn and bracket on passenger's side with the 8MM socket.

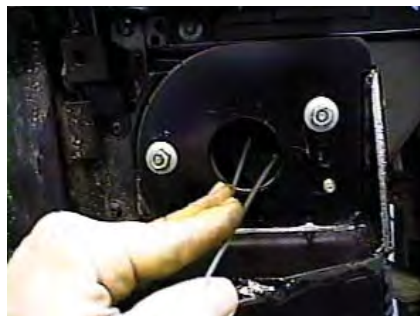

6. Remove all push pins from air dam, pull forward and set aside. Align baseplate with bumper bracket studs and tighten existing metric nut.



Strong As An Ox™



7. Using the baseplate as a template, drill holes in side support bracket with the 13/32" drill bit. Insert item 2 through bumper bracket openings to align with drilled holes and tighten items 3 and 4. **Be sure and use loctite on all bolts before tightening.**
8. While maintaining the distance between bumper brackets (step 5), reinstall brackets with existing metric nuts. Drill remaining holes through bumper bracket, baseplate and frame support with the 13/32" drill bit. Install items 3, 4, and 5 according to drawing on last page. **Be sure and use loctite on all bolts before tightening.**
9. Trim air dam as needed and reinstall. Horn bracket will need to be relocated using item 13. Reinstall fascia. Be sure all electrical connections are plugged in properly.
10. The dimensional variations between otherwise identical cars can be considerable. While the location and size of the holes in the baseplate were designed to allow for easy installation, it may be necessary to file a hole slightly to allow a bolt to clear.
11. Install the tow bar and safety cables according to the instructions included in their packages.
12. Do **not** substitute other devices if the tow bar pin and clip are lost.
13. **DEALER OR INSTALLER: BE CERTAIN THE USER RECEIVES THE INSTRUCTION SHEET.**





Strong As An Ox™

Tools Required

9/16" Socket
50 Torx
13/32" Drill Bit

Loctite
Phillips Screw Driver

7mm Socket
8mm Socket
10mm Socket

Parts List

Ref. No.	Qty.	Part No.	Description
1	1	61-5795	Weldment, Base Plate, BX1302
2	4	61-5208	Weldment, 3/8 Nut Plate 1 x 1 with 14 Inch Wire
3	2	62-3469	Removable Attachment Tab, S/F, LB
4	10	201-0440	3/8-16 x 1 1/2 Hex Bolt Grd. 5, ZP
5	6	203-0003	3/8 Flat Washer, ZP
6	10	203-0010	3/8 Lock Washer, ZP
7	6	202-0003	3/8-16 Hex Nut, ZP
8	2	201-0553	1/4-20 x 1/2 HX. WSHD. Type F, TCS
9	2	101-5822	Adapter, 4 Way Connector
10	2	202-0047	#10-32 Hex Nut
11	2	203-0054	#10 Lock Washer
12	2	201-0192	#10-32 x 1/2 Slot, RD. HD. Screw
13	1	201-0654	#10-16 x 1, Self Drilling Screw
	2	226-0046	Baseplate Safety Cable, 36" CL III (Not Shown)
	2	229-0359	Quicklink, 3/8, ZP (Not Shown)
	2	290-0437	Receiver, Cap Plug (BLK) (Not Shown)



Location for the BX8869, passenger's side.

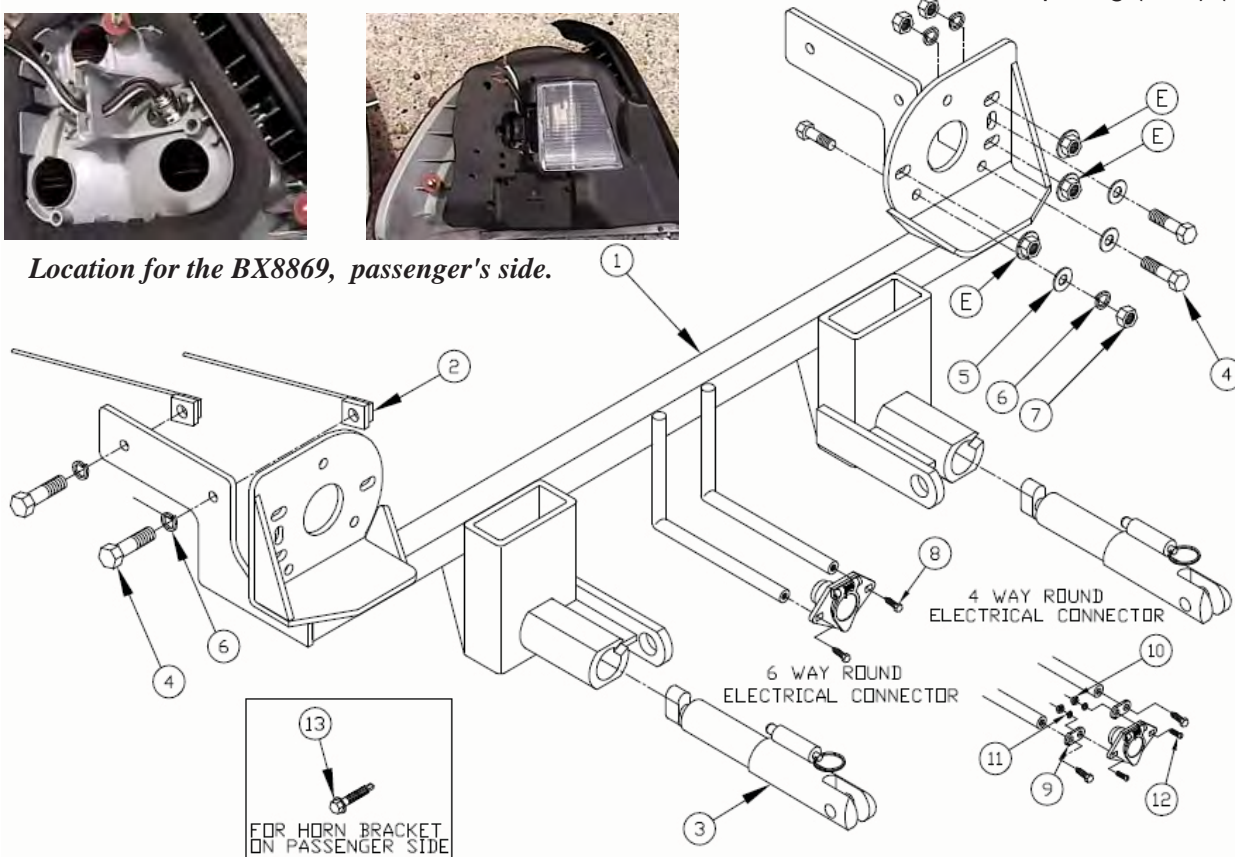

IMPORTANT: Use only genuine factory replacement parts on your Base Plate. Do not substitute homemade or nontypical parts. If a bolt is lost or in need of replacement, for your safety and the preservation of your Base Plate, be sure to use a replacement bolt of the same grade (Usually Grade 5, refer to parts list). Repair parts may be ordered through your nearest **Blue Ox** dealer or distributor.