



Strong As An Ox™

BX1658 Installation Instructions 2004 - 2007 Chevy Aveo (Without Foglights)

Serial No.

The headlight assembly, blinker assembly, front fascia and air baffle are removed for baseplate installation. Drilling is required. The BX8869 is available for the vehicle. Attachment Tabs are 16 inches center to center and a height of 14 1/2 inches.



1. Remove the three Phillips screws and two Phillips push pins from black plastic grill cover on top side of fascia, lift cover and set aside.



2. Remove three metric bolts from headlight assembly with the 10MM socket, pull forward, unplug electrical and set aside, both sides.

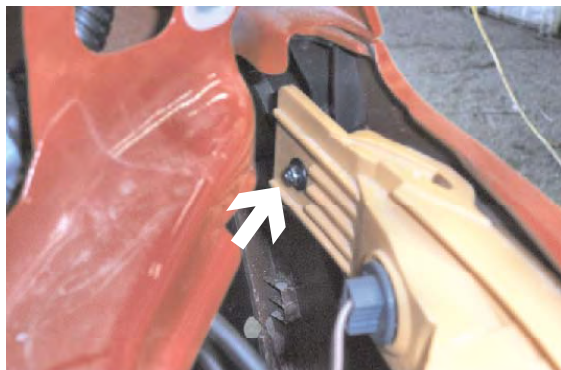

3. Remove two metric bolts from blinker assembly and one push pin just below headlight assembly with the 7MM socket, both sides, unplug electrical connections and set aside.



4. Just below blinker assembly are two push pins to remove, both sides.



5. Just between headlight assemblies, on top edge of fascia, are three push pins to remove.



6. Just forward of front fenders, in wheel well, are two metric bolts to remove on fascia's corner with the 7MM socket, both sides.



Strong As An Ox™



7. Using the phillips screw driver, remove three screws from the upper opening of fascia.



8. Just forward of front tire, on driver's side, is one metric bolt to remove using the 10MM socket.



9. Just forward of front tire, on passenger's side, are two metric bolts to remove using the 10MM socket, pull fascia forward and set aside.



10. Remove the two metric bolts and one metric hex nut, disconnect tube on passenger's side and set air baffle aside.

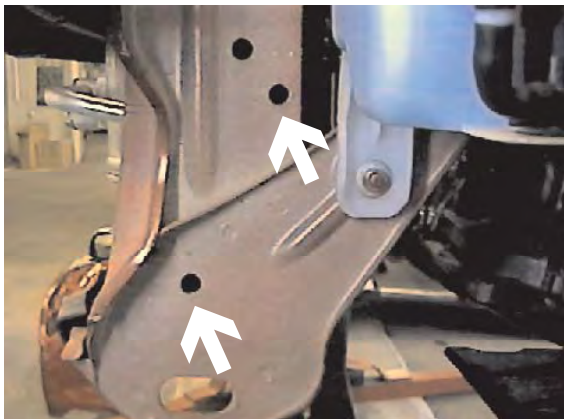

11. Locate these two existing holes on lower frame extension, just above tie down bracket and drill out with the 13/32" drill bit, both sides.



12. Cut a hole into the bottom of frame extension just below tie down bracket (view of driver's side) using the 1 1/2" hole saw, both sides.



Strong As An Ox™

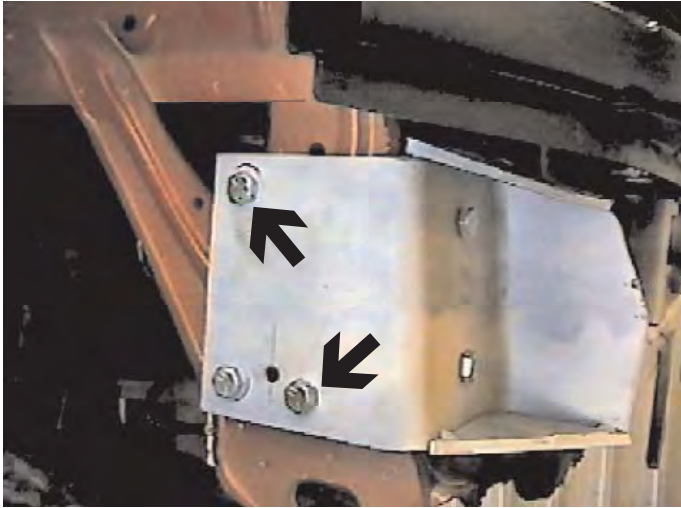

13. While holding baseplate and spacer to align with the upper existing hole on the side of frame extension, insert 3/8-16 x 2" hex bolt through baseplate's top hole and 1" spacer and into upper existing hole. Install 3/8" lock washer and hex nut on the back side of webbing, but do not tighten, both sides. Insert 3/8" nut plate into 1 1/2" drilled hole in the bottom of frame extension to align with lower existing hole. Insert 3/8-16 x 2" hex bolt and lock washer into baseplate's side lower front hole, through 3/4" spacer, into lower existing hole and tighten all bolts while making sure that baseplate is snug against front of frame extension, both sides. **Be sure to use loctite on all bolts before tightening. Tighten all bolts according to Torque Chart in General Instruction Sheet.**

14. Using the baseplate as a template, drill the two holes on the front of baseplate and the back hole on the baseplate's side with the 13/32" drill bit, both sides. Insert the 3/8" nut plates into the 1 1/2" drilled hole of lower frame extension to align with drilled holes on the front of the baseplate, tighten 3/8-16 x 1 1/2" bolts and lock washers, both sides. Insert 3/8-16 x 2" hex bolt into lower back hole of baseplate's side, through 3/4" spacer and into drilled hole on frame side, tighten 3/8" lock washer and hex nut, both sides. **Be sure and use loctite on all bolts before tightening. Torque all bolts according to Torque Chart in General Instruction sheet.**

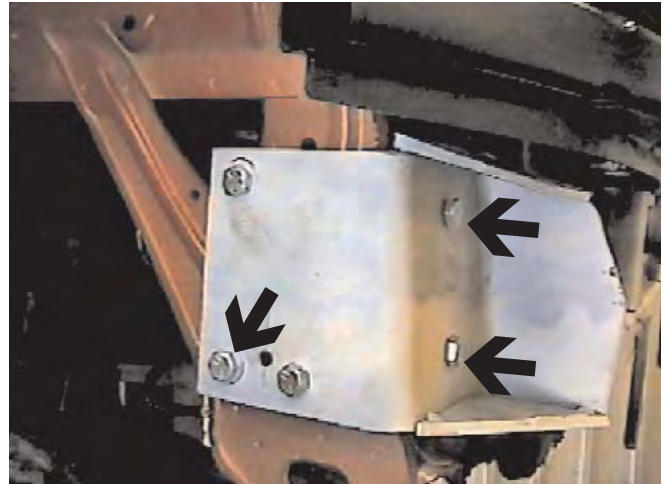

15. Reinstall air baffle on passenger's side using the 1/4-20 x 1 1/2" hex bolt, flat washer, lock washer and 1/4-20 hex nut on front bolt location as shown in photo. Use the existing hex nut and hex bolt for the back bolt locations. Be sure the connecting tube is properly installed.



Strong As An Ox™

16. Reinstall fascia, blinker assembly, headlight assembly, and upper grill. Be sure all electrical components are plugged in properly.
17. The dimensional variations between otherwise identical cars can be considerable. While the location and size of the holes in the baseplate were designed to allow for easy installation, it may be necessary to file a hole slightly to allow a bolt to clear.
18. Install the tow bar and safety cables according to the instructions included in their packages.
19. Do **not** substitute other devices if the tow bar pin and clip are lost.
20. **DEALER OR INSTALLER: BE CERTAIN THE USER RECEIVES THE INSTRUCTION SHEET.**



*Location for the
Bx8869 on driver's side
tail light assembly.*

Tools Required

7MM Socket	10MM Socket	9/16" Socket
Loctite	13/32" Drill Bit	1 1/2" Hole Saw
Phillips Screw Driver	Vise Grips	

IMPORTANT: Use only genuine factory replacement parts on your Base Plate. Do not substitute homemade or nontypical parts. If a bolt is lost or in need of replacement, for your safety and the preservation of your Base Plate, be sure to use a replacement bolt of the same grade (Usually Grade 5, refer to parts list). Repair parts may be ordered through your nearest **Blue Ox** dealer or distributor.



Strong As An Ox™

Parts List

Ref. No.	Qty.	Part No.	Description
1	1	61-6025	Weldment, Base Plate, BX1658
2	4	107-1753	Spacer Tube, 3/4 x .406(ID) Inch
3	2	107-2683	Spacer Tube, 1 x .406(ID) Inch
4	6	61-5208	3/8-16 Nut Plate, With 14" Wire
5	4	201-0368	3/8-16 x 1 1/4 Bolt, Grd. 5, ZP
6	6	201-0444	3/8-16 x 2 Bolt, Grd. 5, ZP
7	10	203-0010	3/8 Lock Washer, ZP
8	4	202-0003	3/8-16 Hex Nut, ZP
9	1	201-0448	1/4-20 x 1 1/2 Bolt, Grd. 5, ZP
10	1	203-0001	1/4 Flat Washer, ZP
11	1	203-0008	1/4 Lock Washer, ZP
12	1	202-0001	1/4-20 Hex Nut, ZP
13	2	201-0553	1/4-20 x 1/2 Hx. Wshd, Type F Screw
14	2	201-0192	#10-32 x 1/2 Slot, Rd. Hd. Screw
15	2	203-0054	#10 Lock Washer
16	2	202-0047	#10-32 Hex Nut
17	2	101-5822	Adapter, 4 Way Connector
18	2	62-3469	Attachment, Assembly, SF/ LB (R)
	2	226-0046	Baseplate Safety Cable, 36" CL III (Not Shown)
	2	229-0359	Quicklink, 3/8, ZP (Not Shown)
	2	290-0437	Receiver, Cap Plug (BLK) (Not Shown)

