



## BX1824 Installation Instructions 1999-00 Nissan Frontier (4WD/ 4 and 6 Cylinder)

The baseplate mounts to the top of the frame and frame brackets. The attachment tabs will extend through the grill opening four inches. A plastic molded guard located directly behind the bumper is permanently removed. Six 3/8 inch holes need to be drilled for installation.

1. Remove the bolt that holds the rod support to the outside ends of the bumper. Remove the push pins from the bottom of the bumper. Locate the bolt above the rods that hold the outside edges of the bumper to the frame (in front of the tires and above the rubber cushion). Facing the bumper and looking through the grill are bolts fastening the bumper to the outside brackets and to each frame. Reach inside the grill opening and remove these bolts. Remove the bolts holding the plastic guard to the bumper. Be careful the bumper does not fall.
2. Notice the two existing holes on top of each frame, place the baseplate (Item 1) on the frame. Line up the top front hole to the existing holes. Mark and drill 3/8 inch holes for the remaining holes on each side of the baseplate. See Diagram 1.
5. Replace the bumper. **Note: The plastic piece removed in Step 3 is not replaced. Be sure to give the piece to the owner.**
6. Install the tow bar and safety cables according to the instructions included in their packages.

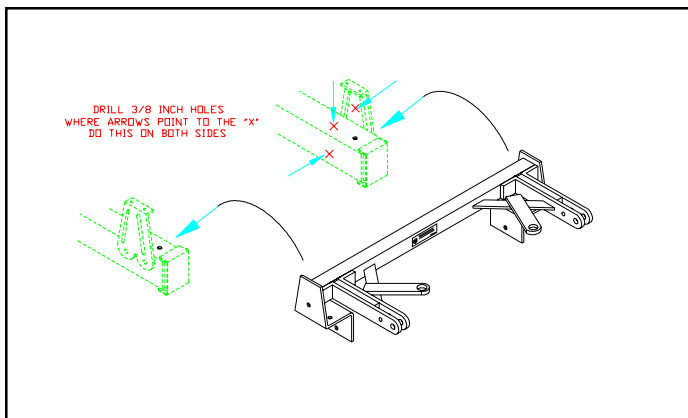

Diagram 1

3. Inside the frame is a piece of metal obstructing the top back holes. Use a screw driver and push the metal back so a bolt can be inserted. On the front of each frame is a piece of metal. Pry open a large enough gap so the wire nuts (Item 2) can be inserted. See Diagram 2.
4. Bolt the baseplate to the frame. Use Loctite on each bolt. Tighten bolts once they have all been started. **NOTE:** Use spacers (Item 6) two on one side and three on the other for 2000 models.

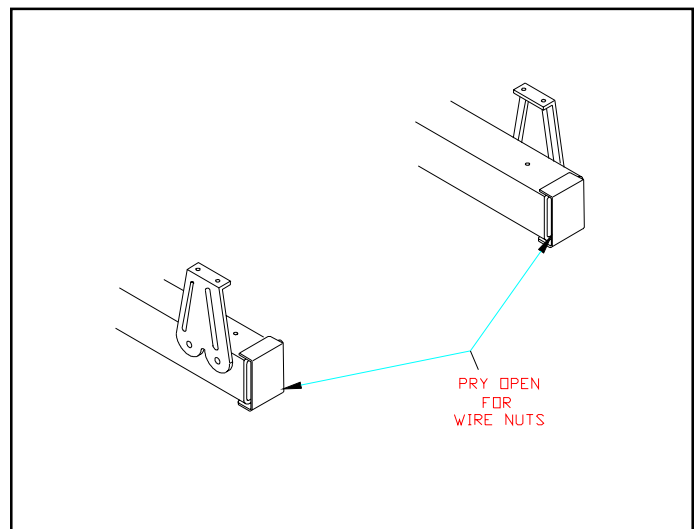

Diagram 2

7. Do not substitute other devices if the tow bar pins or clips are lost.
8. **DEALER OR INSTALLER: BE CERTAIN THE USER RECEIVES THE INSTRUCTION SHEET.**



# Automatic

## Tools Required

10MM Wrench  
Phillips Screw Driver

10MM Socket  
Small Pry Bar

12MM Wrench  
3/8 Drill Bit

12MM Socket  
Loctite Blue or Red

## Parts List

Ref. No.	Qty.	Part No.	Description
1	1	61-5380	Weldment Baseplate, BX1824
2	6	61-4902	3/8 Wire Nut
3	8	201-0368	3/8-16 x 1 1/4 Hex Bolt, Grade 5
4	2	202-0003	3/8 Hex Nut
5	8	203-0010	3/8 Lock Washer
6	5	102-5890	Plate Spacer, BX1824
7	2	201-0444	3/8-16 x 2 Hex Bolt, Grade 5 (used with Spacer Plates)



1998-99 MODELS

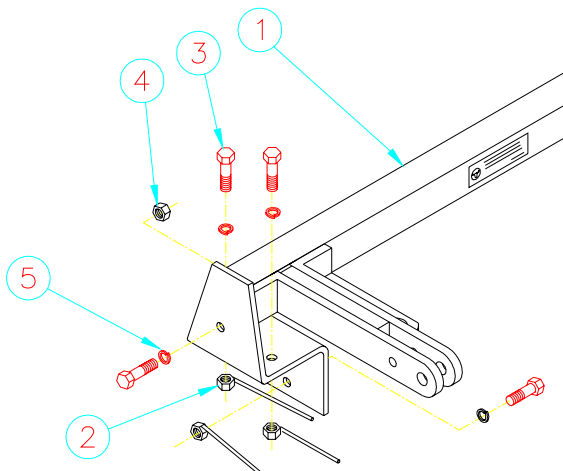

2000 MODELS

