



Strong As An Ox™

## BX1830 Installation Instructions 2000-03 Nissan Maxima SE (No Foglights)

Serial No.

The front fascia and tie down brackets are removed for baseplate installation. Factory tie down brackets will not be reinstalled. No holes need to be drilled. The BX8869 is available for the vehicle. Attachment Tabs are 24 inches center to center and a height of 13 3/4 inches.



1. Remove the four push pins on the top side of fascia.



2. Just forward of front tire, on fascia corner, remove one screw with the phillips screw driver, both sides.



3. Remove four push pins on the bottom side of the fascia. Unplug fog lights, if applicable.



4. Just forward of front tire and behind fascia corner, remove the two metric bolts on lower fascia corner, using the 10MM socket, both sides. Pull fascia forward and set aside.

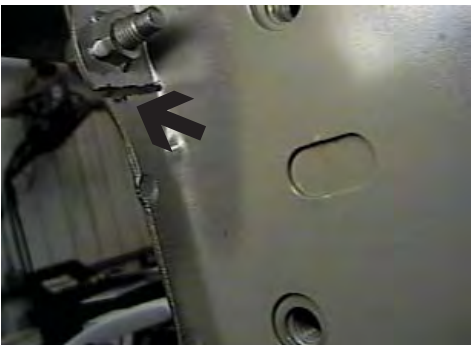

5. Cut frame ribbing, just forward of tow hook, with the hack saw. Using the 14MM socket, remove the three metric bolts from tie down bracket and set aside. Factory tie down bracket will **not** be reinstalled.



6. Hold baseplate to align with tie down bracket holes. Fasten with existing metric bolt from tie down bracket, both sides, and tighten all bolts. **Be sure and use loctite on all bolts before tightening.**



Strong As An Ox™



7. Hold fascia in place to its original position, mark, trim, and reinstall fascia. Be sure electrical connections are made to fog lights.
8. The dimensional variations between otherwise identical cars can be considerable. While the location and size of the holes in the baseplate were designed to allow for easy installation, it may be necessary to file a hole slightly to allow a bolt to clear.
9. Install the tow bar and safety cables according to the instructions included in their packages.
10. Do **not** substitute other devices if the tow bar pin and clip are lost.
11. **DEALER OR INSTALLER: BE CERTAIN THE USER RECEIVES THE INSTRUCTION SHEET.**



12. Photo of the drivers side tail light assembly and location for the BX8869.



## Tools Required

Loctite Blue  
Hack Saw

10MM Socket  
14MM Socket

Vise Grips  
Phillips Screw Driver

## Parts List

Ref. No.	Qty.	Part No.	Description
1	1	61-5778	Weldment, Base Plate, BX1830
2	6		Existing Metric Bolts for Tow Factory Hooks
3	2	201-0553	1/4-20 x 1/2 Hx. Wshd, Type F Screw
4	2	201-0192	#10-32 x 1/2 Slot, Rd. Hd. Screw
5	2	203-0054	#10 Lock Washer
6	2	202-0047	#10-32 Hex Nut
7	2	101-5822	Adapter, 4 Way Connector

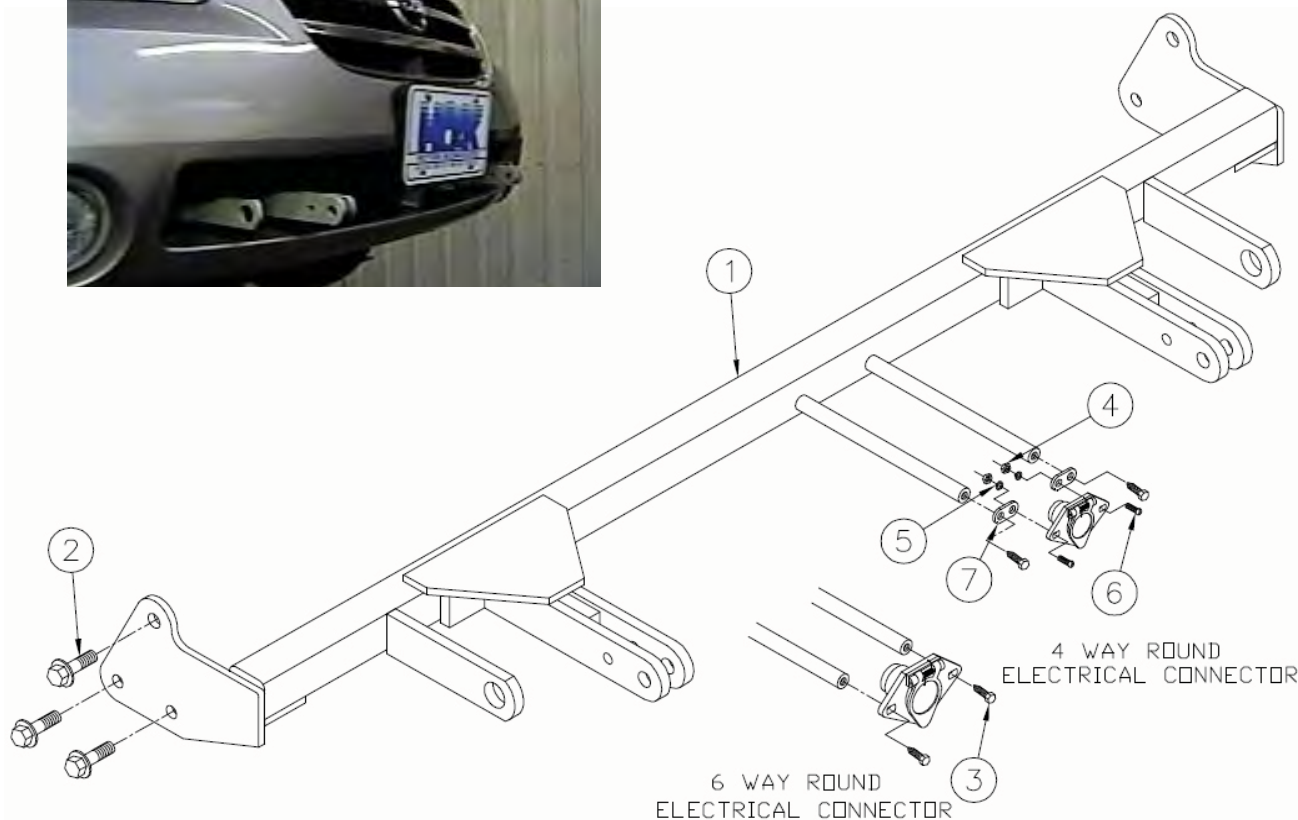

**IMPORTANT:** Use only genuine factory replacement parts on your Base Plate. Do not substitute homemade or nontypical parts. If a bolt is lost or in need of replacement, for your safety and the preservation of your Base Plate, be sure to use a replacement bolt of the same grade (Usually Grade 5, refer to parts list). Repair parts may be ordered through your nearest **Blue Ox** dealer or distributor.