



Strong As An Ox™

BX1958 Installation Instructions 2003-04 Mitsubishi Montero

Serial No.

The front fascia and windshield washer reservoir are removed for baseplate installation. Drilling is required. Trimming of air dam is required. The BX8869 is available for the vehicle. Attachment Tabs are 17 inches center to center and a height of 21 1/2 inches.



1. Remove the three push pins from black plastic cover on top side of fascia, lift cover and set aside.



2. Release the four clips on the top edge of fascia just under plastic in step 1.



3. Just inside of head lights pull grill forward to release on both sides, lift up and set aside.

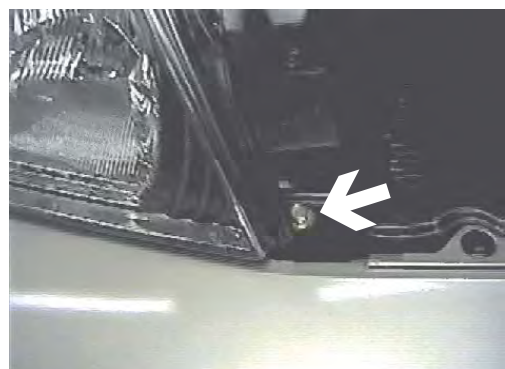

4. Remove three metric bolts from the top of metal bumper between headlights with the 10MM socket.



5. Remove the three push pins just forward of the front tire, both sides.



6. Pull plastic back just forward of front tires and remove two metric bolts from back side of fascia's corner with the 10MM socket, both sides.



Strong As An Ox™



7. Using the 12MM socket, remove two metric bolts from the front of the belly pan, loosen the two back metric bolts and set aside.



8. Remove four push pins from bottom edge of front fascia, just under belly pan and two just forward of front tires on the bottom edge of fascia, both sides.

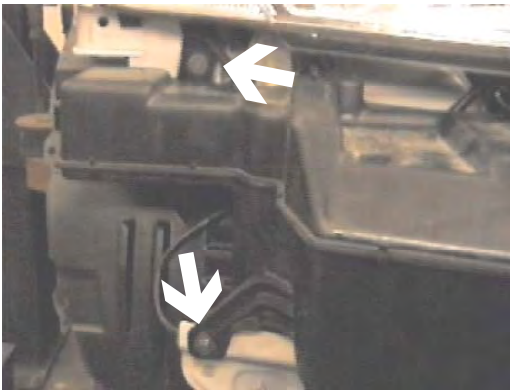

9. Remove three metric bolts from washer reservoir on passenger's side, using the 10MM socket. Lift reservoir up to release alignment pin from top of frame, unplug electrical connections, disconnect and plug water lines.



10. Using the hack saw, cut alignment pin from the bottom of reservoir tank.



11. Bend brackets up on both sides to open area for baseplate insertion.



12. Drill one hole in frame on the outer side next to sensor, using the 1 1/4" hole saw, both sides.



Strong As An Ox™

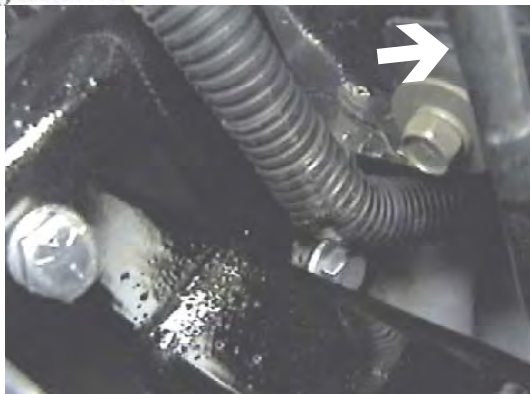

- 13.** Set baseplate (item 1) on the top and in between the frame end just behind bumper brackets. While making sure that the baseplate is tight against the top of frame, using the baseplate as a template, drill the two holes to the inside of the frame rails with the 13/32" drill bit, both sides. Be cautious of coolant line on passenger's side (see arrow) when drilling lower hole. Insert drill bit into a piece of pipe or deep socket while drilling, to protect coolant line. Insert nut plates into 1 1/4" drilled hole to align with these drilled holes, tighten 3/8" bolt and lock washer, both sides. **Be sure to use loctite on all bolts before tightening. Tighten all bolts according to Torque Chart in General Instruction Sheet.**
- 14.** Using the baseplate as a template, drill the two remaining holes on the top of frame rails with the 13/32" drill bit, each side. Insert nut plates into 1 1/4" drilled hole to align with these drilled holes, tighten 3/8" bolt and lock washer, both sides. **Be sure to use loctite on all bolts before tightening. Tighten all bolts according to Torque Chart in General Instruction Sheet.**
- 15.** Reinstall windshield washer reservoir, fascia and belly pan. **Be sure all electrical components and hoses are plugged in properly before installing fascia.**
- 16.** The dimensional variations between otherwise identical cars can be considerable. While the location and size of the holes in the baseplate were designed to allow for easy installation, it may be necessary to file a hole slightly to allow a bolt to clear.
- 17.** Install the tow bar and safety cables according to the instructions included in their packages.
- 18.** Do **not** substitute other devices if the tow bar pin and clip are lost.
- 19. DEALER OR INSTALLER: BE CERTAIN THE USER RECEIVES THE INSTRUCTION SHEET.**



Strong As An Ox™

Tools Required

10MM Socket
12MM Socket
9/16" Socket

13/32" Drill Bit
Flat Screw Driver
Phillips Screw Driver

Vise Grips
Loctite

Parts List

Ref. No.	Qty.	Part No.	Description
1	1	61-5921	Weldment, Base Plate, BX1958
2	1	101-6135	Electrical Bracket
3	8	61-5208	Weldment, 3/8-16, Nut Plate w/ Wire
4	8	201-0440	3/8-16 x 1 1/2 Bolt, Grd. 5, ZP
5	8	203-0010	3/8 Lock Washer, ZP
6	2	201-0654	#10-16 x 1 Self Drilling Screw
7	2	201-0569	1/4-20 x 3/4 Hex Bolt, Grd. 5, ZP
8	2	203-0008	1/4 Lock Washer, ZP
9	2	202-0001	1/4-20 Hex Nut, ZP
10	2	201-0192	#10-32 x 1/2 Slot, Rd. Hd. Screw
11	2	203-0054	#10 Lock Washer
12	2	202-0047	#10-32 Hex Nut
13	2	101-5822	Adapter, 4 Way Connector
14	2	62-3469	Attachment, Assembly, SF/ LB (R)
	2	226-0046	Baseplate Safety Cable, 36" CL III (Not Shown)
	2	229-0359	Quicklink, 3/8, ZP (Not Shown)
	2	290-0437	Receiver, Cap Plug (BLK) (Not Shown)

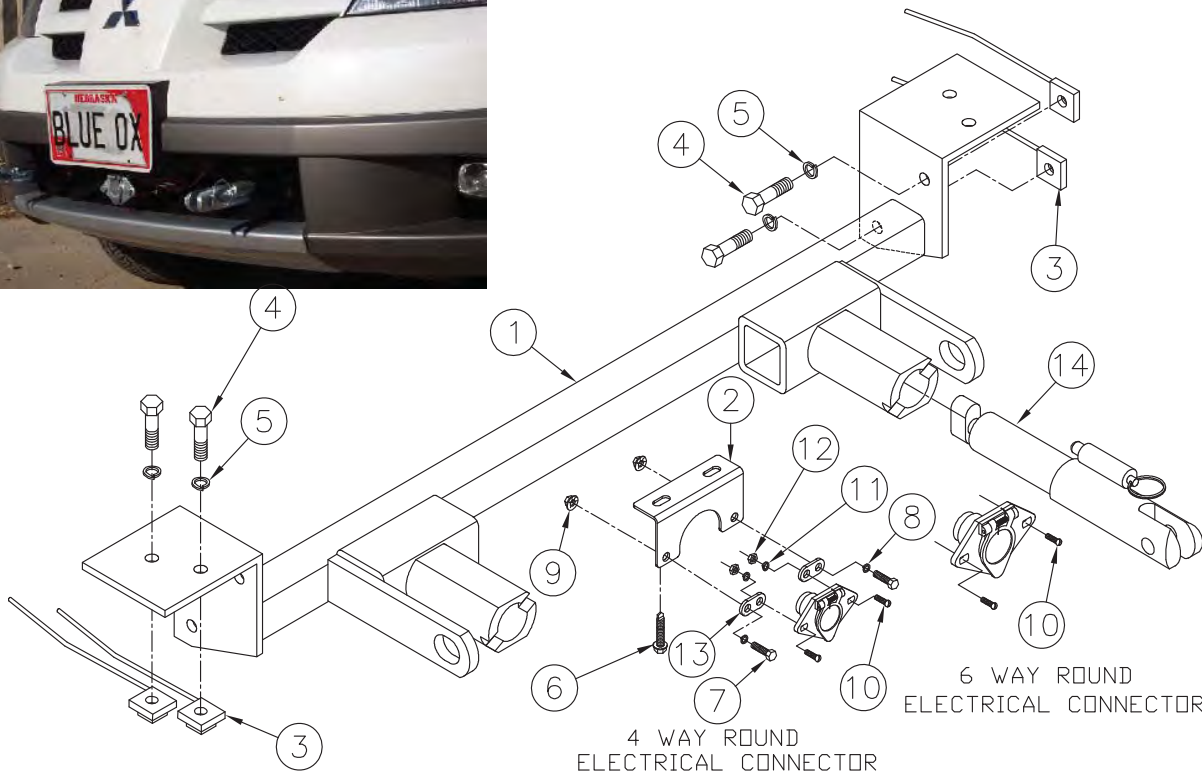

IMPORTANT: Use only genuine factory replacement parts on your Base Plate. Do not substitute homemade or nontypical parts. If a bolt is lost or in need of replacement, for your safety and the preservation of your Base Plate, be sure to use a replacement bolt of the same grade (Usually Grade 5, refer to parts list). Repair parts may be ordered through your nearest **Blue Ox** dealer or distributor.