



Strong As An Ox™

## BX1960 Installation Instructions 2003 Mitsubishi Lancer

Serial No.

The headlight assemblies, front fascia and metal bumper are removed for baseplate installation. Drilling is required. Trimming of lower grill opening is required. The BX8869 is available for the vehicle. Attachment Tabs are 24 inches center to center and a height of 16 inches.



1. Remove two metric bolts and two push pins from the top side of fascia tabs and one metric bolt by hood latch, using the 10MM socket.



2. Using the flat screw driver, pull top fascia's edge back to expose and remove two push pins that release inner fascia's brace.



3. Just inside headlight assembly is one metric bolt to remove with the 10MM socket, both sides.



4. Remove two metric bolts from the top side of headlight assemblies with the 10MM socket, pull assemblies forward, unplug electrical connections and set aside.



5. Remove the two push pins just forward of the front tire on fascia's edge, both sides.



6. Pull wheel well cover back to remove metric bolt from fascia's top corner with the 10MM socket.



Strong As An Ox™



7. Push grill back to expose and remove two push pins from lower opening with the needle nose pliers( see photo step eight).



8. Remove two push pins from tabs on lower fascia's edge using the needle nose pliers.



9. Remove eight push pins from lower fascia's edge, pull fascia forward and set aside.



10. Remove two metric bolts from the bottom of frame with the 12MM socket on both sides, pull metal bumper forward and set aside.



11. Drill one hole in bumper bracket on top of frame, one in bumper bracket and webbing. Insert 3/8" hex nut and lock washer into frame opening to align with drilled hole and tighten 3/8-16 x 1 bolt. Align 3/8" hex nut and lock washer with hole on the bottom side of webbing, tighten 3/8-16 x 1" bolt. **Be sure and use loctite on all bolts before tightening. Torque all bolts according to the torque chart in the General Instruction sheet.**

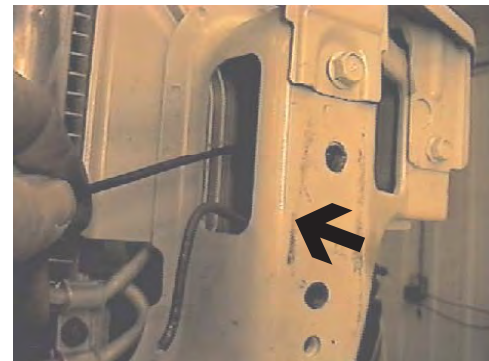

12. Drill out existing hole and drill all the way through to the back side of radiator cross member, both sides. **Be sure there is nothing behind cross member before drilling.**



Strong As An Ox™

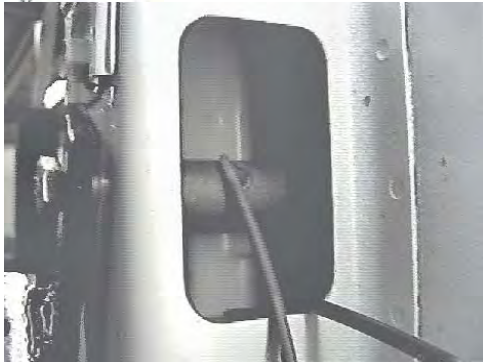

13. Insert 3/8-16 x 4" bolt into top passenger's side baseplate hole, align with drilled hole in frame on passenger's side (step 12), insert spacer tube inside frame to align with hole, through to the back side of cross member. Tighten 3/8-16 hex nut, flat and lock washer, both sides. **Be sure and use loctite on all bolts before tightening. Torque all bolts according to the torque chart in the General Instruction sheet.**



14. Reinstall metal bumper into vehicle openings. Align small spacer tubes and plate supports with existing holes on the bottom of frame, tighten 8MM-1.5 x 50MM bolt and lock washer, both sides (photo shows driver's side). **Be sure and use loctite on all bolts before tightening. Torque all bolts according to the torque chart in the General Instruction sheet.**

15. Using the baseplate as a template, drill the remaining holes through cross member and support plate on the back side. Insert 3/8-16 x 4" hex bolt through lower hole in baseplate end, spacer tube with wire and plate support. Tighten hex nut and lock washer. Insert 10MM hex bolt through center hole in baseplate end, spacer tube with wire and plate support. Tighten hex nut and lock washer. **Be sure and use loctite on all bolts before tightening. Torque all bolts according to the torque chart in the General Instruction sheet.**



16. Lay fascia face down on a soft surface and trim off the back side of the lower grill with the utility knife, as shown in photo, both sides.

17. Hold fascia to align with its original position. Using the utility knife mark and trim lower grill to allow baseplate to come through.



Strong As An Ox™

- 18 Reinstall headlight assemblies and fascia. **Be sure all electrical components are plugged in properly.**
19. The dimensional variations between otherwise identical cars can be considerable. While the location and size of the holes in the baseplate were designed to allow for easy installation, it may be necessary to file a hole slightly to allow a bolt to clear.
20. Install the tow bar and safety cables according to the instructions included in their packages.
21. Do **not** substitute other devices if the tow bar pin and clip are lost.
22. **DEALER OR INSTALLER: BE CERTAIN THE USER RECEIVES THE INSTRUCTION SHEET.**

### Tools Required

13MM Socket  
Needle Nose Pliers  
Phillips Screw Driver

15MM Socket  
Loctite  
Vise Grips

9/16" Socket  
13/32" Drill Bit  
Flat Screw Driver



*Location for the  
Bx8869 on driver's side  
tail light assembly.*



Strong As An Ox™

### Parts List

Ref. No.	Qty.	Part No.	Description
1	1	61-5918	Weldment, Base Plate, BX1960
2	6	61-5942	Weldment, 7/8 OD. Tube, with 10" Wire
3	4	107-2611	Tube, 1 OD. x 7/32" Wall x 3/4"
4	1	101-6562	Plate, Support, PS, BX1960
5	1	101-6561	Plate, Support, DS, BX1960(Not Shown)
6	4	201-0618	3/8-16 x 4 Hex Bolt, Grd. 5, ZP
7	6	203-0003	3/8 Flat Washer, ZP
8	8	203-0010	3/8 Lock Washer, ZP
9	8	202-0003	3/8-16 Hex Nut, ZP
10	2	201-0612	10MM-1.25 x 140MM Hex Bolt, Grd. 8.8, ZP
11	2	203-0103	10MM Flat Washer, ZP.
12	2	202-0119	10MM Hex Nut, ZP
13	4	201-0419	8MM-1.25 x 50MM Hex Bolt, Grd. 8.8, ZP
14	4	203-0107	8MM Flat Washer, ZP
15	2	201-0553	1/4-20 x 1/2 Hx. Wshd, Type F Screw
16	2	201-0192	#10-32 x 1/2 Slot, Rd. Hd. Screw
17	2	203-0054	#10 Lock Washer
18	2	202-0047	#10-32 Hex Nut
19	2	101-5822	Adapter, 4 Way Connector
	4	201-0443	3/8-16 x 1 Hex Bolt, Grd. 5, ZP (Not Shown)
	2	226-0046	Baseplate Safety Cable, 36" CL III (Not Shown)
	2	229-0359	Quicklink, 3/8, ZP (Not Shown)

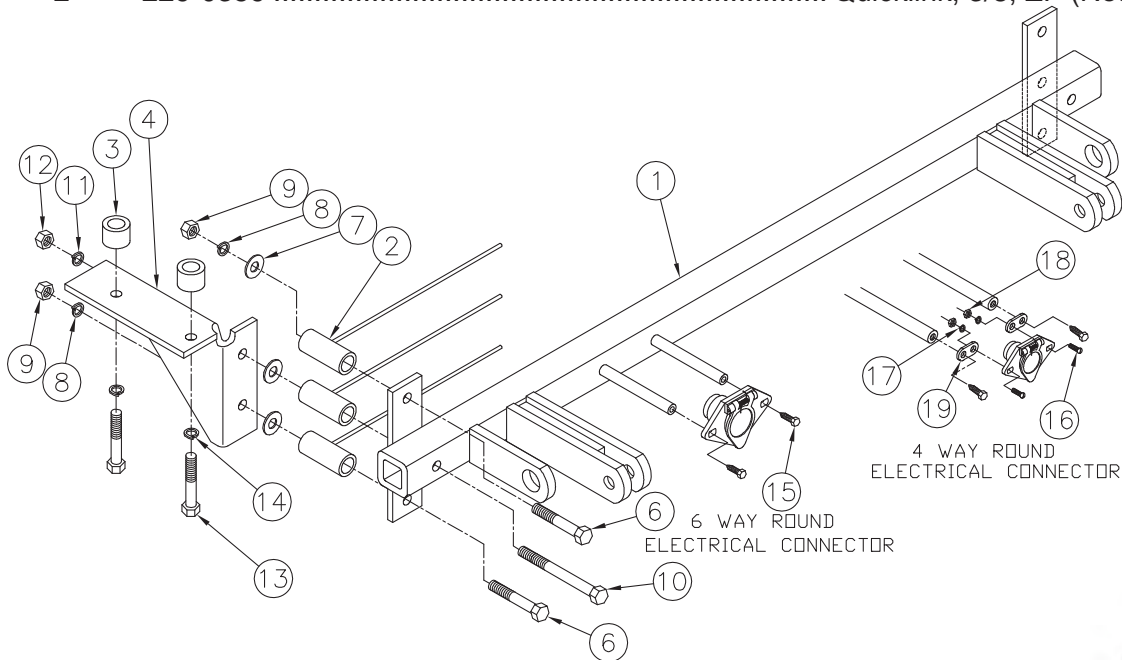

**IMPORTANT:** Use only genuine factory replacement parts on your Base Plate. Do not substitute homemade or nontypical parts. If a bolt is lost or in need of replacement, for your safety and the preservation of your Base Plate, be sure to use a replacement bolt of the same grade (Usually Grade 5, refer to parts list). Repair parts may be ordered through your nearest **Blue Ox** dealer or distributor.