



Strong As An Ox™

BX1967 Installation Instructions 2004 Dodge Durango

Serial No.

The metal bumper and tow hooks are removed for baseplate installation. **Tow hooks will not be reinstalled.** Drilling is required. The BX8869 is available for the vehicle. Attachment Tabs are 29 inches center to center and a height of 15 inches.



1. Remove the four metric bolts from metal bumper brackets using the 18MM socket, both sides, pull metal bumper forward and set aside. Slide baseplate up to the outside of frame rails, align between ribs on frame sides and clamp to frame with vise grips as shown in photo. **NOTE: Some vehicles may require the removal of the tow hooks. Tow hooks will NOT be reinstalled.**
2. Using the baseplate as a template, drill the hole on the bottom side of frame with the 17/32" drill bit, both sides. Insert 1/2" hex bolt into lock washer, drilled hole, align 1/2" nut plate to hex bolt from frame end and tighten bolt, both sides. **Be sure and use loctite on all bolts before tightening. Tighten all bolts according to torque chart in the General Instruction Sheet.**
3. Using the baseplate as a template, drill the holes on the driver's side into the frame with the 17/32" drill bit. **NOTE: Be aware of wind shield reservoir when drilling back hole, use a short piece of pipe or a deep well socket over drill bit to protect reservoir.** Insert 1/2" hex bolts and lock washers into drilled holes. Align 1/2" nut plates to hex bolt from frame end and tighten bolt. **Be sure and use loctite on all bolts before tightening. Tighten all bolts according to torque chart in the General Instruction Sheet.**





Strong As An Ox™



4. Drill the remaining holes on the passenger's side into the frame with the 17/32" drill bit. Insert 1/2" hex bolts and lock washers into drilled hole. Align 1/2" nut plates to hex bolt from frame end and tighten bolt. **Be sure and use loctite on all bolts before tightening. Tighten all bolts according to torque chart in the General Instruction Sheet.**

5. Reinstall metal bumper.
6. The dimensional variations between otherwise identical cars can be considerable. While the location and size of the holes in the baseplate were designed to allow for easy installation, it may be necessary to file a hole slightly to allow a bolt to clear.
7. Install the tow bar and safety cables according to the instructions included in their packages.
8. Do **not** substitute other devices if the tow bar pin and clip are lost.
9. **DEALER OR INSTALLER: BE CERTAIN THE USER RECEIVES THE INSTRUCTION SHEET.**

Tools Required

18MM Socket
17/32" Drill Bit

3/4" Socket
Vise Grips

Loctite

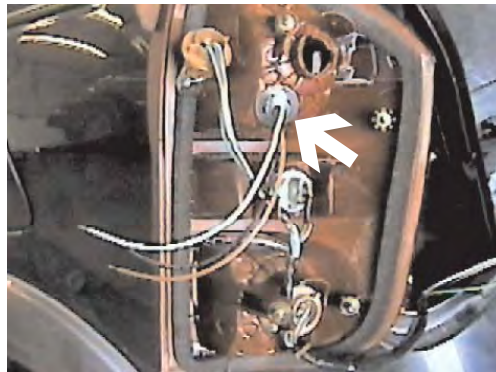

Location for the BX8869 on the driver's side.



Strong As An Ox™

Parts List

Ref. No.	Qty.	Part No.	Description
1	1	61-5994	Weldment, Base Plate, BX1967
2	6	61-4604	1/2-13" Nut Plate, with 10" Wire
3	6	201-0051	1/2-13 x 1 1/2 Bolt, Grd. 5, ZP
4	6	203-0012	1/2 Lock Washer, ZP
5	2	201-0553	1/4-20 x 1/2 Hx. Wshd, Type F Screw
6	2	201-0192	#10-32 x 1/2 Slot, Rd. Hd. Screw
7	2	203-0054	#10 Lock Washer
8	2	202-0047	#10-32 Hex Nut
9	2	101-5822	Adapter, 4 Way Connector
10	2	62-3468	Attachment, Assembly, SF/ SB (R)
	2	226-0046	Baseplate Safety Cable, 36" CL III (Not Shown)
	2	229-0359	Quicklink, 3/8, ZP (Not Shown)
	2	290-0437	Receiver, Cap Plug (BLK) (Not Shown)

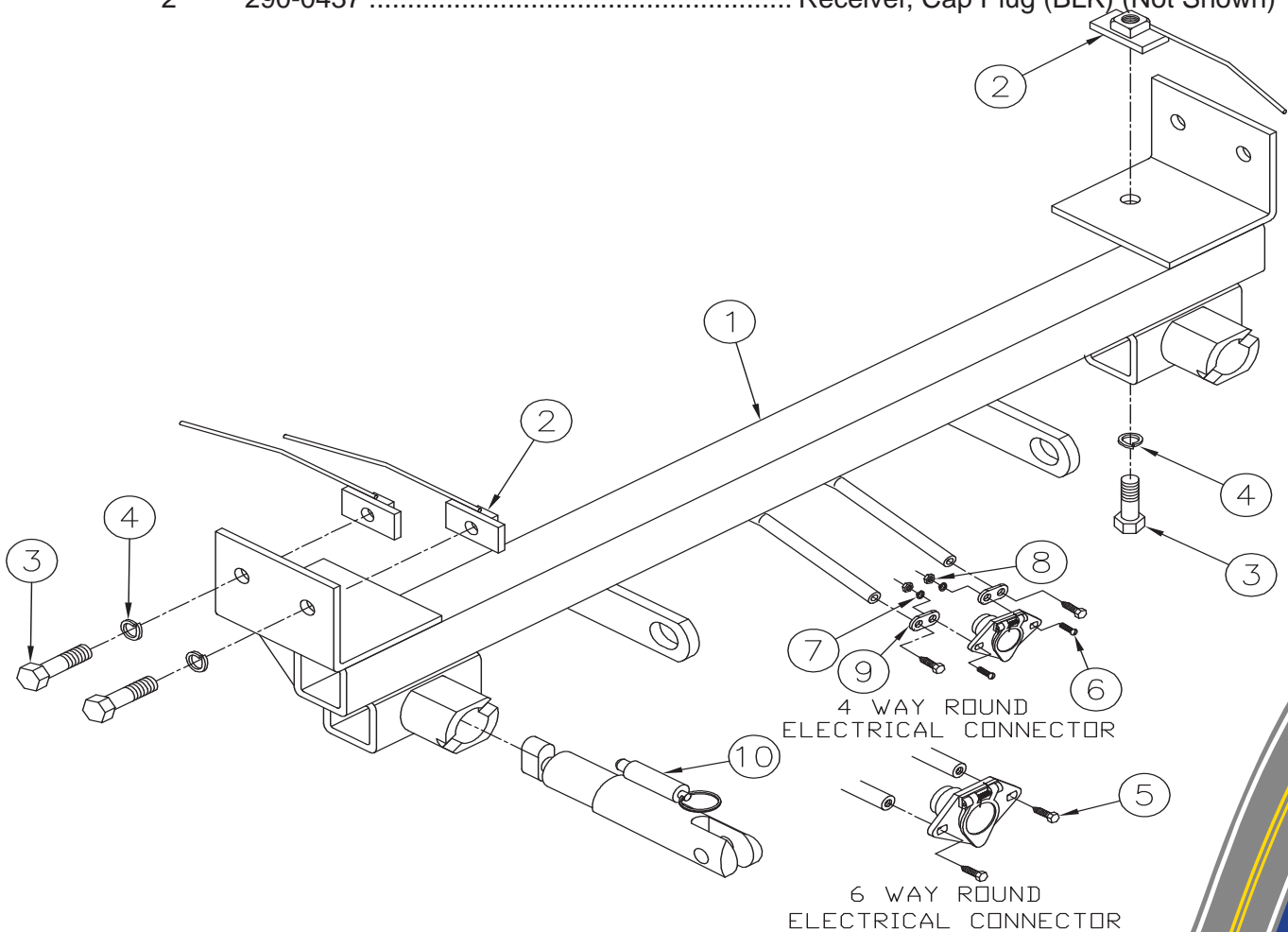

IMPORTANT: Use only genuine factory replacement parts on your Base Plate. Do not substitute homemade or nontypical parts. If a bolt is lost or in need of replacement, for your safety and the preservation of your Base Plate, be sure to use a replacement bolt of the same grade (Usually Grade 5, refer to parts list). Repair parts may be ordered through your nearest **Blue Ox** dealer or distributor.