



BX2131 Installation Instructions 1997-00 Ford F-150 (4WD)

These vehicles weigh over 3500 lbs. and require a Class III (5000 lbs) rated tow bar, hitch and accessories. Utilization of Blue Ox baseplates with any tow bar not approved by Automatic Equipment Mfg. Co. invalidates the limited warranty.

Installation of this baseplate requires removing the bumper.

1. Read the General Instruction Sheet included with this baseplate.
2. Remove the four bolts that hold the bumper to the frame of the truck, remove the electrical connectors to the blinkers and the four plastic inserts that hold the plastic molding to the flexible belly pan.
3. The baseplate (Item 1) will mount to the frame using the same bolt holes that the tow hooks use. Remove the bolts from each tow hook. Place the baseplate and tow hooks on the frame and bolt it in place using the same bolts. The holes in the side of the angle mount will need to be drilled (17/32" drill bit). With the baseplate (Item 1) bolted to the frame, punch and drill the side holes of the baseplate. If you cannot reach all the holes of the baseplate (Item 1), you may have to remove it and then drill the holes.
4. Bolt on the baseplate (Item 1) and tow hooks, and secure all the bolts. Use the 1/2 x 1 1/2" bolts (Item 3) and 1/2" washers (Item 4 & 5) with the wire nuts (Item 6). Be sure to use Loctite with all the bolts to ensure that they will not loosen.
5. Replace the bumper and the flexible molding to its original positions.
6. Install the tow bar and safety cables according to the instructions included in their packages.
7. Do not substitute other devices if the tow bar pin and clip are lost.
8. **DEALER OR INSTALLER: BE CERTAIN THE USER RECEIVES THE INSTRUCTION SHEET.**

Tools Required

10mm Wrench
13mm Wrench

3/4" Wrench
17/32" Drill Bit

Loctite Blue

Automatic

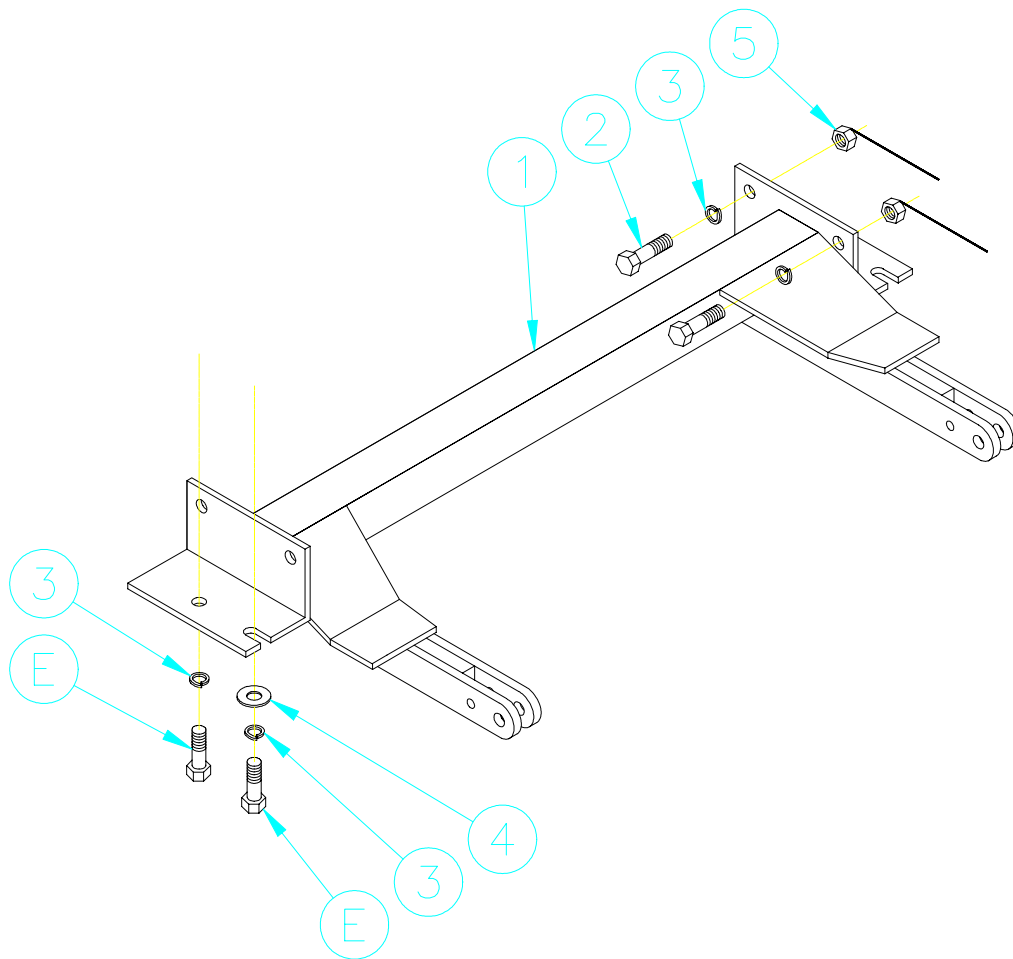

Parts List

Ref. No.	Qty.	Part No.	Description
1	1	61-4943	Baseplate, BX2131
2	4	201-0051	1/2-13 x 1 1/2" Hex Bolt, Grade 5
3	8	203-0012	1/2" Lock Washer
4	2	203-0005	1/2" Flat Washer
5	4	61-4029	1/2" Wire Nut
6	4	xxx-xxx	Existing Bolts