



Strong As An Ox™

**BX2165 Installation Instructions
2003-06 Mercury Grand Marquis
2003-06 Lincoln Town Car**

Serial No.

Drilling is necessary. No trimming of the fascia is needed. The BX8869 is available for this vehicle. Attachment tabs are 24 inches center to center and a height of 11 1/2 inches. **Be sure to use loctite on all bolts before tightening. Tighten all bolts according to torque chart in general instruction sheet.**



1. *Unscrew 3 pins from black plastic on the top edge of fascia, lift up and set aside.*

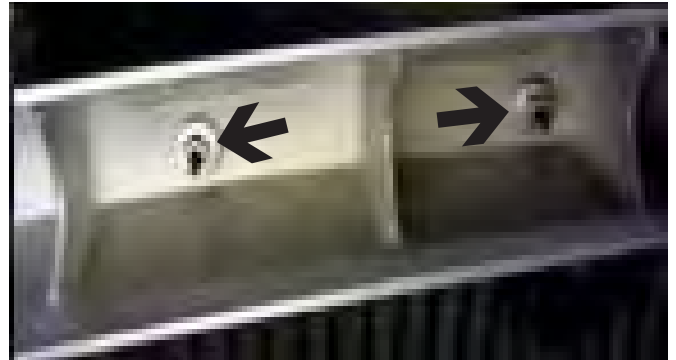

2. *Remove the six hex nuts on the back top edge of the fascia with 11MM socket. Pull the front chrome grill forward and set aside.*



3. *Just behind the head light assemblies are three metric bolts to remove using an 8MM socket, both sides. Pull assemblies forward and set aside, both sides.*



4. *Remove two metric hex nuts from both blinker assemblies, located just behind head light area, using the 11MM socket, pull to the side, unplug and set aside.*

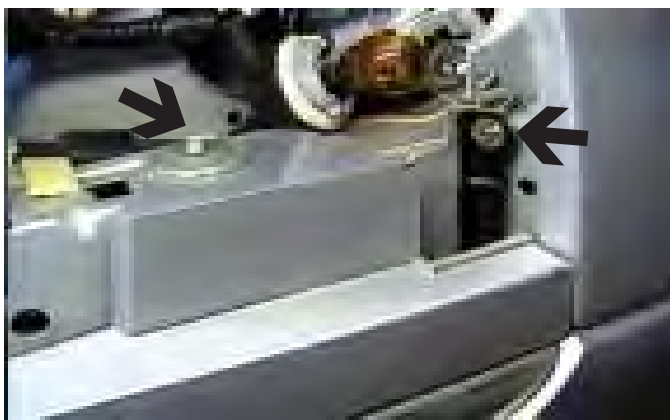

5. *Using the 5MM & 8MM sockets, remove the two hex head screws from blinker opening on each side.*



6. *Remove the three Christmas tree pins just forward of front tire, both sides.*



Strong As An Ox™



7. Remove the eight screws with washers on the underside of bumper fascia with an 8MM socket.



9. Using the 8MM socket, remove the metric screw from the lower side of air dam on both sides.

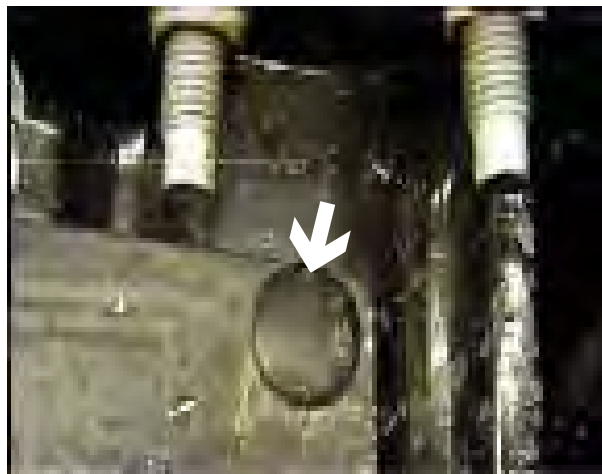

11. Remove the Christmas tree push pin from air dam on both sides and set aside. Air dam will be trimmed and reinstalled later.

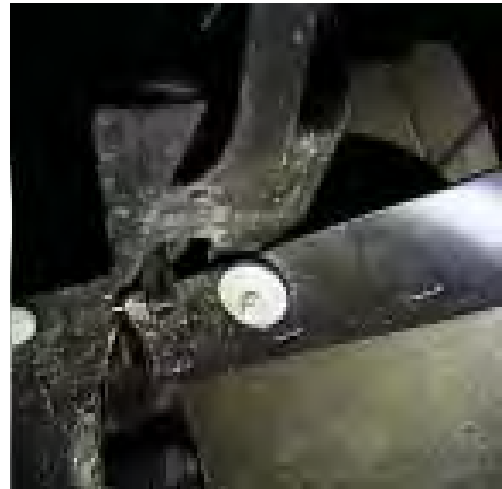

8. Using a 10MM socket, remove the screw from the lower black panel located forward of front tires and below air dam, both sides.

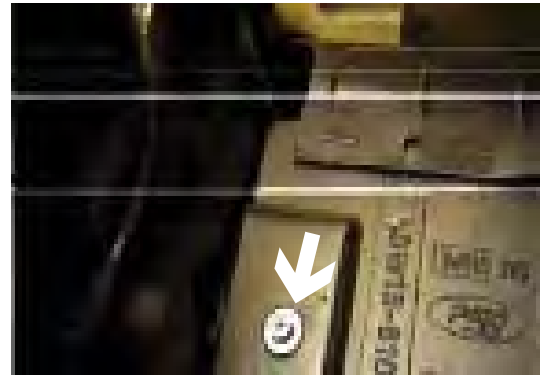

10. Just behind metal bumper, remove one metric screw on air dam with a 7MM socket, both sides.

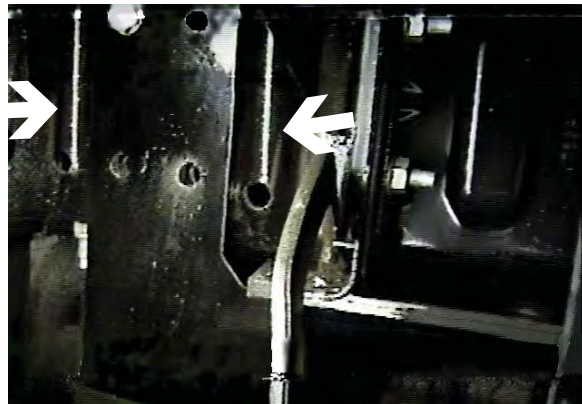

12. Using two people, slide the baseplate up on to the frame, aligning the two outside end plates go in between the two dimples on the out board side of frame.



Strong As An Ox™



13. Slide a 3/8 spacer in between the frame and baseplate on both sides, then clamp the baseplate securely. Using the baseplate as a template, drill one 13/32" hole on each side, see photo in step 12. Install and tighten, one 3/8-16 x 1 1/2 hex bolt, lock washer and wire nutplate, on each side. Hold fascia in place to make sure baseplate is level and attachment points come through fascia openings, see photo below. Make adjustments as needed. Then drill the rest of the 13/32" holes on each side. Finish bolting the baseplate to the car frame. **Be sure to use loctite on all bolts before tightening. Tighten all bolts according to torque chart in General Instruction Sheet.**

14. Trimming of air dam is needed before reinstalling. Then reinstall air dam, lower panel (forward of front tires), fascia, blinker and head light assemblies, chrome grill insert and upper fascia black plastic.

15. The dimensional variations between otherwise identical cars can be considerable. While the location and size of the holes in the baseplate were designed to allow for easy installation, it may be necessary to file a hole slightly to allow a bolt to clear.

16. Install the tow bar and safety cables according to the instructions included in their packages.

17. Do **not** substitute other devices if the tow bar pin and clip are lost.

18. **DEALER OR INSTALLER: BE CERTAIN THE USER RECEIVES THE INSTRUCTION SHEET.**





Tools Required

5MM Socket
10MM Socket
Loctite Red

7MM Socket
11MM Socket
13/32" Drill Bit

8MM Socket
9/16 Socket
Vise Grips

Parts List

Ref. No.	Qty.	Part No.	Description
1	1	61-5901	Weldment, Base Plate, BX2165
2	8	61-5208	Weldment, Nutplate
3	8	201-0440	3/8-16 x 1 1/2 Hex Bolt, Grd.5, ZP
4	8	203-0010	3/8 Lock washer, ZP
5	2	201-0553	1/4-20 x 1/2 Hex Washer Head, Type F, Screw, ZP
6	2	101-5822	Adapter, 4-way Connector
7	2	201-0192	#10-32 x 1/2 Slot, Rd. Hd Screw
8	2	202-0047	#10-32 Hex Nut, ZP
9	2	203-0054	#10 Lock Washer, ZP
	2	226-0049	Baseplate Safety Cable, 36" CL IV (Not Shown)
	4	229-0512	Quicklink, 1/2, ZP (Not Shown)

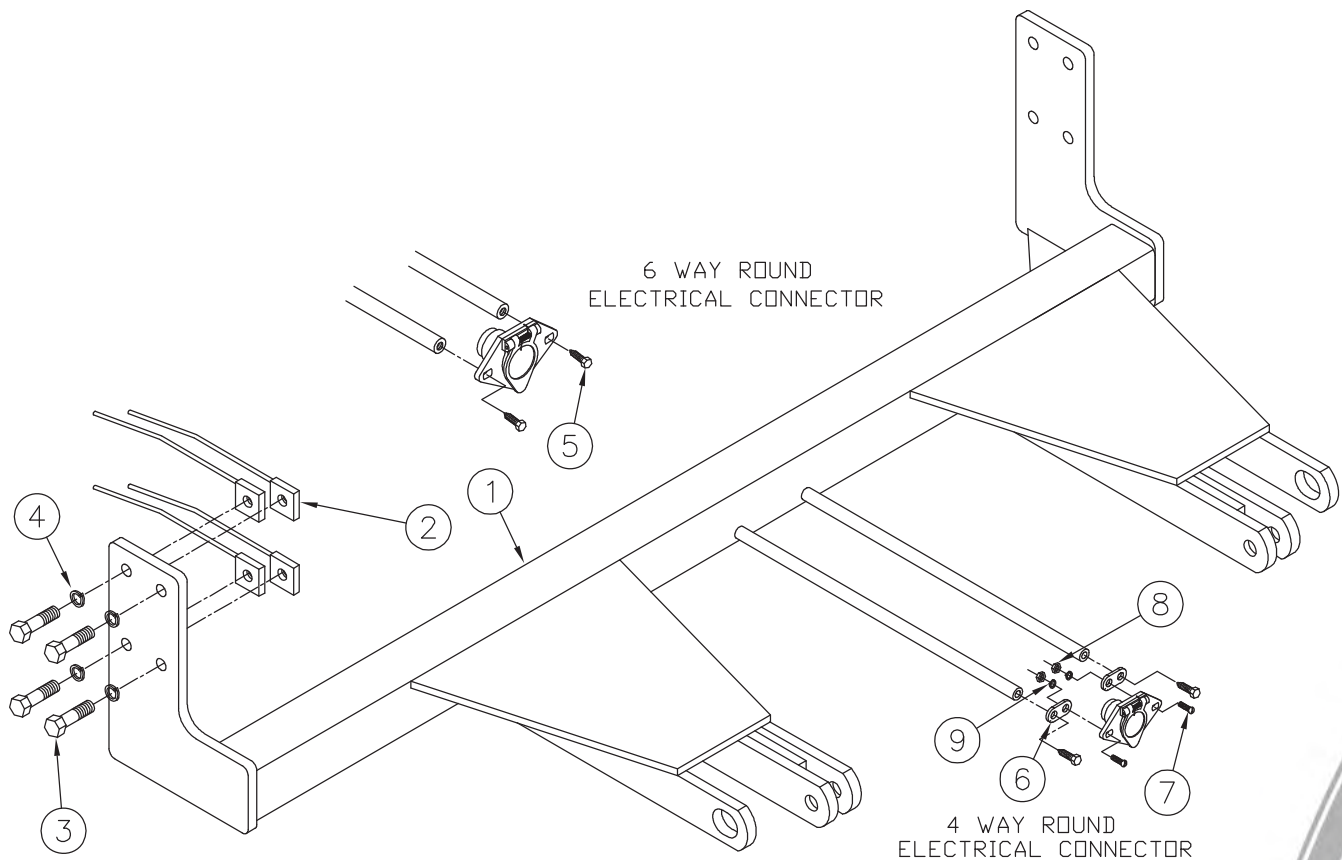

IMPORTANT: Use only genuine factory replacement parts on your Base Plate. Do not substitute homemade or nontypical parts. If a bolt is lost or in need of replacement, for your safety and the preservation of your Base Plate, be sure to use a replacement bolt of the same grade (Usually Grade 5, refer to parts list). Repair parts may be ordered through your nearest **Blue Ox** dealer or distributor.