



# Installation Instructions

## *TH-700R4 (4L60) Transmission*

### *with 30 tooth input shaft spline*

**Part Number 117101, 117102, 117103, 107101, 107104, 117301, & 117302**

©2002, 2001, 1999, 1994 by B&M Racing and Performance Products

The B&M TH-700R4 is a specially modified transmission intended for performance and heavy duty applications. It is suitable for use behind engines producing up to 450 lb-ft of torque. This covers most small block Chevrolets and mild big blocks.

1982-85 and some 1986-87 TH-700's controlled the Torque Converter Clutch (TCC) with hydraulic valves located in the valve body. In most 1986 and later TH-700's the TCC shift valve was plugged and TCC is controlled by an Electronic Control Module (ECM). **ALL B&M TH-700 (4L60) TRANSMISSIONS ARE BUILT FOR ECM CONTROL OF THE TCC.** If you are replacing a 1982-87 transmission with hydraulic TCC control you will have to do one of the following: Swap valve bodies from your original transmission to the new one or, purchase an electronic TCC control (B&M P/N 70244). For installation into vehicles not originally equipped with a TH-700, see **Section 2** for instructions on how to control the Torque Converter Lockup clutch. A lockup torque converter is desirable but not required with this transmission. To prevent the transmission from overheating adequate oil cooling is required especially if running an open (non-lockup) converter. If you are installing a non-lockup torque converter you must also disconnect the TCC Solenoid to maintain proper oil flow in the converter (refer to instructions accompanying the non-lockup converter). The torque converter for this transmission must have a 30 tooth spline turbine hub. B&M offers a complete line of converters for a wide range of performance and towing applications. See the B&M catalog for the latest offerings including the Tork Master and Holeshoot torque converters.

The TH-700 (4L60) transmission does not use a vacuum modulator like some GM transmissions. Instead it uses a Throttle Valve (TV) linkage mechanism to control line pres-

sure. It is essential that the TV cable be attached to the carburetor or throttle body and properly adjusted. If the cable is not connected correctly, the transmission will not shift correctly and it may fail. See Section 3 for instructions on connecting the TV cable in vehicles not originally equipped with a TH-700.

#### **1. TRANSMISSION INSTALLATION**

**STEP 1:** Assemble torque converter to transmission. Lubricate the torque converter pump drive hub with clean transmission fluid before installation.

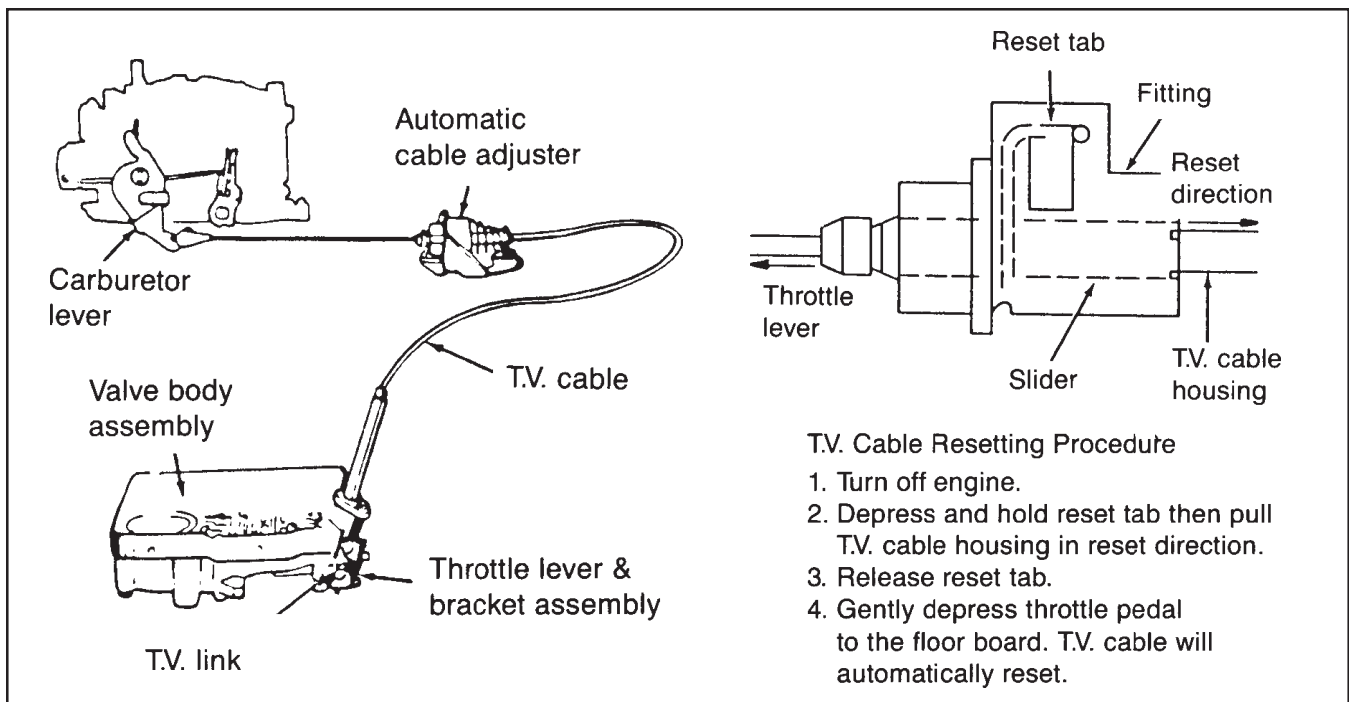
**STEP 2:** The engine block's transmission mounting face must be free of any dirt or burrs. Make sure both dowel pins are installed and stick out of the block approximately 1/2" to insure proper transmission alignment.

**STEP 3:** Remove and inspect the flexplate for distortion, cracks or damaged ring gear teeth. If the flexplate shows any damage it should be replaced. Do not attempt to repair a damaged flexplate.

**STEP 4:** Assemble the flexplate to crankshaft and align all holes before installing the bolts. When properly installed the raised inner lip on the flexplate should face away from the crankshaft flange. Torque the bolts to 81 Nm (60 ft.lbs.).

**STEP 5:** Place the transmission in position on transmission jack. Make sure the jack supports the transmission on a wide area so the oil pan is not crushed. Install the transmission / converter against the engine. The transmission should engage the dowel pins and sit flat against the block with hand pressure only. If the transmission does not sit flat against the engine, the converter is not fully engaged in the transmission or some other interference problem exists.

**WARNING: Do not attempt to pull the transmission**



**FIG. 1 Resetting T.V. Cable**

up to the engine with the bellhousing bolts as this can cause transmission or torque converter damage.

**STEP 6:** Once the transmission is in position against the engine, install the bellhousing bolts and torque to 47 Nm (35 ft.lbs.). At this point the torque converter should turn freely.

**IMPORTANT:** A tight converter indicates improper engagement, a distorted flexplate or binding pilot hub. **This condition must be corrected before going further.**

**STEP 7:** Inspect transmission mount. Worn, cracked or broken transmission and/or engine mounts should be replaced. Raise transmission and install crossmember assembly then tighten all bolts. Install three (M10 x 1.5 x 15) flexplate to converter bolts. Install the first bolt finger tight then use the starter motor to "bump" each drive lug into position. When all three bolts are installed torque them to 47Nm (35 ft.lbs.).

**STEP 8:** (FIG. 1) Reconnect and adjust the TV cable.

**WARNING:** You must reset the TV cable before operating the transmission. Failure to reset the TV cable will result in poor shift quality and early transmission failure.

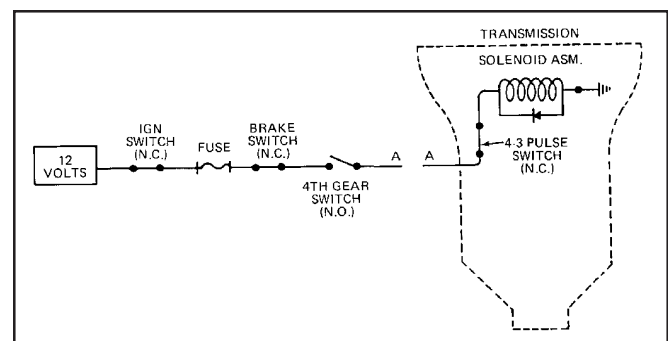
**IMPORTANT:** If you are using the transmission in any type of custom installation see Section 3 for details on how to set up the T.V. cable so it works correctly.

**STEP 9:** Connect speedometer cable, electrical connector and shifter cable. Make sure the cooler tube connector fittings are tight in transmission case first, then connect cooler lines and tighten the tube compression nuts with a fitting wrench to avoid damaging the nuts.

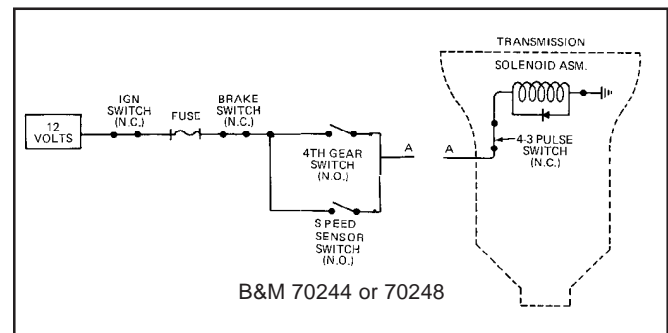
**STEP 10:** Install drive shaft (and torque arm if used). Make sure the U joint cups (bearings) are properly positioned in their seats. Tighten U joint nuts or bolts securely.

**STEP 11:** Lower vehicle but keep the rear wheels off the

ground if possible. Add six (6) quarts of B&M TRICKSHIFT or DEXRON® III fluid to the transmission. Place transmission in **NEUTRAL** and start the engine. Add fluid to transmission until the fluid level is between the **FULL** and **ADD** marks. Shift the transmission through all gear positions. If the wheels are off the ground, allow the transmission to shift through all gears several times. Place selector in **NEUTRAL** and check the fluid level again. **DO NOT OVER-**

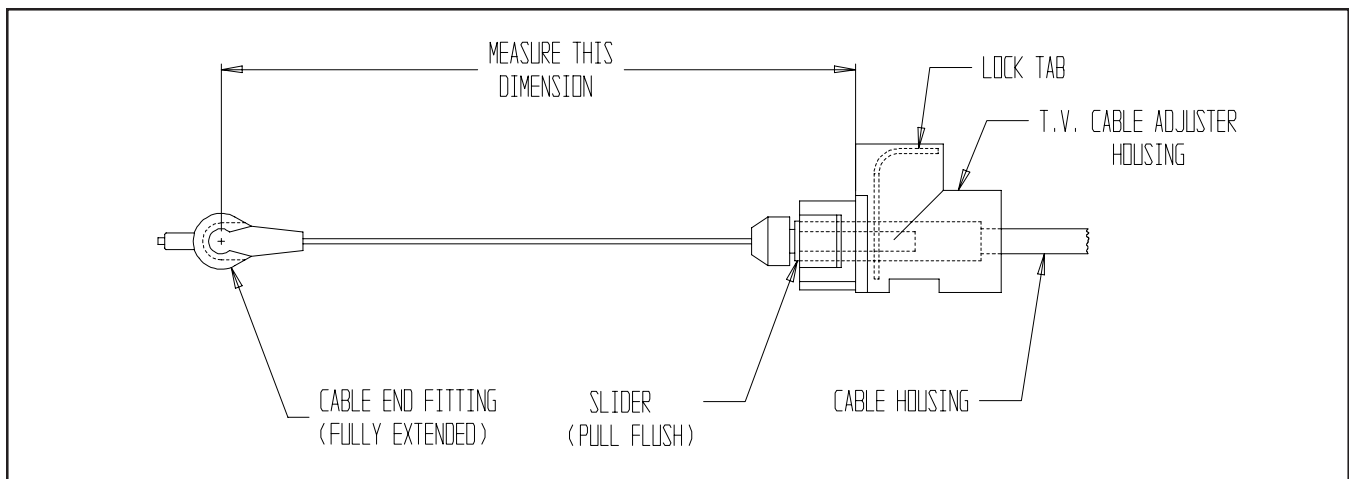


**FIG. 2 4th Gear Only TCC Wiring**



**FIG. 3 Speed Sensor Controlled TCC Wiring**

B&M 70244 or 70248



**FIG. 4**

**FILL.** Check for leaks around the oil pan, cooler lines, etc.

## 2. CONTROLLING THE TORQUE CONVERTER CLUTCH ENGAGEMENT

In stock applications the torque converter clutch (TCC) engagement is controlled by either a speed dependent hydraulic pressure signal from the TCC shift valve train or ECM control depending on the valve body configuration. When this control signal is present and the TCC solenoid is energized the TCC Apply valve (located in the Oil Pump Body) moves to engage the TCC. In most non-stock applications the ECM signal is not available to signal TCC engagement. The TCC engagement on your B&M transmission is controlled electrically.

There are two approaches to control the TCC. In the first and simplest, the TCC solenoid is wired in series with a normally open pressure switch in the 4th gear circuit (see FIG. 2) and a switch attached to the brake pedal. With this arrangement TCC engagement occurs when the transmission shifts to 4th gear, also the TCC is automatically disengaged when the brake pedal is depressed. See (FIG 2) for an example wiring diagram.

The second approach is to install a speed sensing device (such as **B&M P/N 70244 or 70248**) which controls the TCC engagement as a function of vehicle speed. This allows TCC engagement to be adjusted to occur any speed or gear (above 1st) which may be desirable for fuel economy considerations. As a safety precaution a pressure switch should also be installed in the 4th gear circuit that acts in parallel with the speed sensor switch. The pressure switch will insure TCC engagement in 4th gear should the speed sensor switch become misadjusted or inoperative. See (FIG. 3) for an example wiring diagram.

## 3. THROTTLE VALVE MECHANISM

The purpose of the TH700-R4 Throttle Valve (T.V.) and it's mechanical linkage is to control both the shift feel and

shift timing as a function of vehicle speed and load conditions. As the accelerator pedal is depressed and the throttle opens, the T.V. mechanical linkage relays the motion to the throttle plunger in the valve body by way of the T.V. cable. In factory installations of the TH700-R4 the geometric relationship between the T.V. cable and throttle shaft bellcrank produces the required T.V. cable extension (pull) to throttle opening for the transmission to function properly. In custom installations the correct T.V. cable mounting geometry must be accurately determined if the transmission is to function properly. It cannot be overstated that for the TH700-R4, proper T.V. cable installation and adjustment are paramount to proper transmission function and life. If the T.V. cable is not operating correctly, the transmission life will be greatly reduced.

The following procedure will show you how to design a custom T.V. Cable installation that works. The main objective is to accurately position the T.V. cable mounting bracket in relation to the throttle shaft axis to obtain the proper T.V. CABLE EXTENSION (PULL) TO THROTTLE OPENING relationship.

**STEP 1.** Measure your T.V. cable to establish it's particular mounting dimension (there are several lengths in use) as follows (see Fig.4). Retract the slider by depressing the lock tab then pull the cable housing until the flats on the slider are flush with the end of the adjuster housing then fully extend the cable by pulling the cable end fitting out (slider must remain retracted) until it stops. Holding the end fitting out, measure the dimension from the face on the adjuster housing that registers with the mounting bracket to the center of the cable end connector.

**STEP 2.** Add 3/16" (0.19 in.) to the measurement obtained in **Step 1**, this is the perpendicular measurement from the REAR FACE of the T.V. cable mounting bracket to the WIDE OPEN THROTTLE position of the T.V. cable connector pin on the throttle bellcrank (see Fig. 5).

**STEP 3.** The T.V. cable bellcrank must be perpendicular (90 degrees) to the T.V. cable when the throttle is 25 percent (1/4) open (see Fig. 5), this geometric relationship is

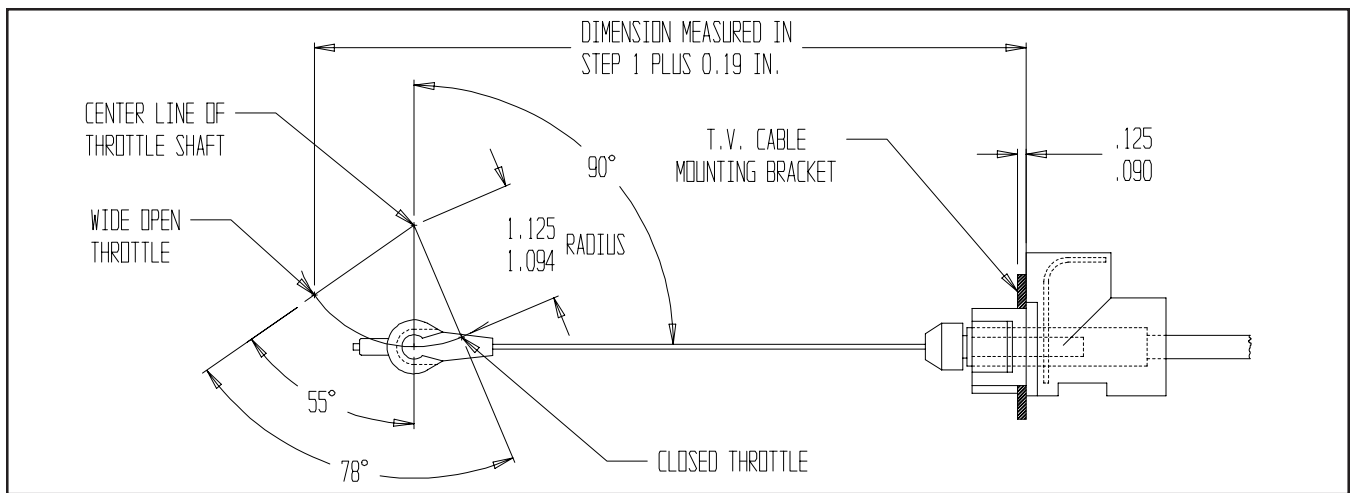


FIG. 5

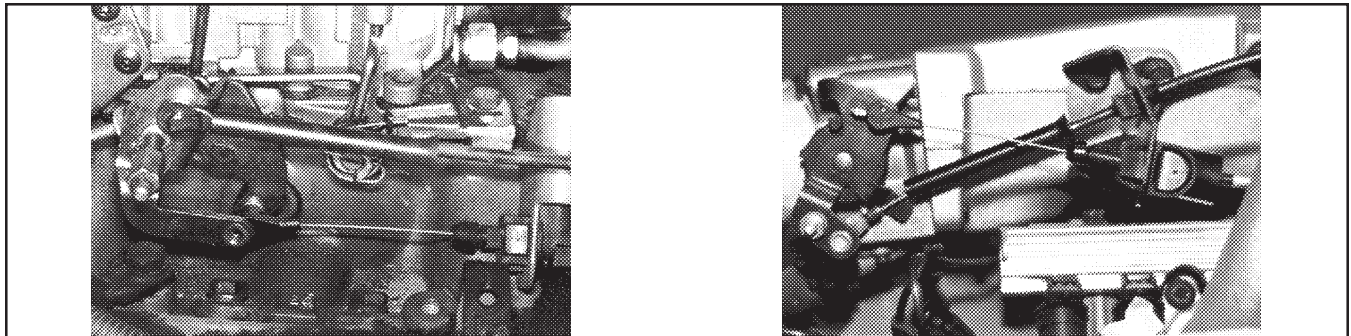


FIG. 6

critical to insure that the T.V. mechanism moves in the correct proportion to the throttle opening. The mounting location for the T.V. cable connector pin will have to be established on the throttle bellcrank at a radius of 1.094 / 1.125 in. There may be a suitable existing hole at the correct radius on the throttle bellcrank, otherwise you will have to fabricate an attachment to the bellcrank that will properly locate the connector pin.

Diagrams of several typical factory installations are shown for reference (see Fig. 6). Notice the geometric relationship between the T.V. cable bellcrank (attached to the carburetor or the throttle body) and the mounting bracket. Several things should be kept in mind during this stage of the design:

1. The proper location of the T.V. cable mounting bracket is determined by the angular and radial position of the T.V. cable connector pin on the throttle bellcrank.
2. Make sure that all of the cables or rods that will be attached to the throttle bellcrank do not interfere with each other when the throttle is advanced from idle to wide open.
3. Mount the T.V. cable adjuster housing so that the locktab is readily accessible and not blocked by other cables, rods, brackets or other engine mounted accessories.

**STEP 4.** Fabricate T.V. cable bracket using 0.090 - 0.125 in. sheet metal (see Fig. 7) for the adjuster housing cut-out dimensions. If you use the thicker stock a chamfer

will be required on two sides of the cable mounting cutout to allow the lock tabs to expand properly. The T.V. cable adjuster requires a pull of about 18 lbs. to ratchet out, so try to make the mounting bracket as rigid as possible. If the mounting bracket flexes the T.V. pressure will not be consistent.

#### 4. SERVICE & DIAGNOSIS GENERAL TRANSMISSION DESCRIPTION

The TH700-R4 is a fully automatic transmission for rear wheel drive vehicles which provides four forward gear ranges

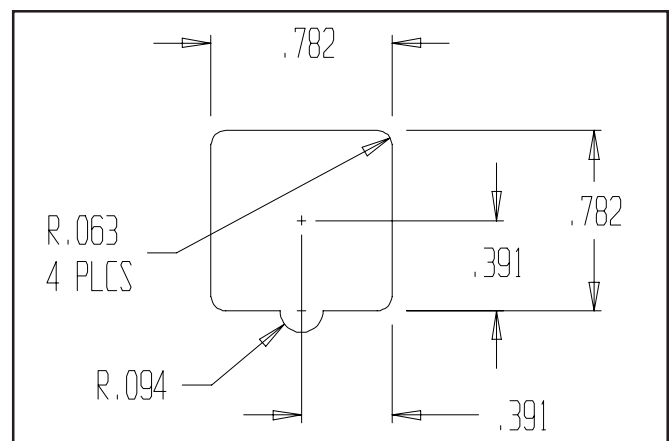


FIG. 7

and reverse.

The oil pressure and shift points are controlled by the throttle opening via the Throttle Valve cable.

The transmission can be operated in any of the seven different modes.

- P** Park position prevents the vehicle from rolling either forward or backward. (For safety reasons the parking brake should be used in addition to the Park position.)
- R** Reverse position allows the vehicle to be operated in the rearward direction.
- N** Neutral position allows the vehicle to be started and operated without driving the vehicle. If necessary this position may be selected - the engine must be restarted with the vehicle moving.
- D** Overdrive position is used for all normal driving conditions. It provides four gear ratios plus converter clutch operation. Downshifts are available for safe passing by depressing the accelerator pedal.
- 3** Drive position is used for city traffic, hilly terrain, and trailer towing. It provides three forward ranges plus converter clutch operation. Downshifts are available for safe passing by depressing the accelerator pedal.
- 2** Manual second position is used to provide acceleration and engine braking. This range may be selected at any vehicle speed.
- 1** Manual Low position is used to provide maximum engine braking.

## SERVICE

Because of the tremendous pressures and heat developed in the TH700 in high performance applications you should check the transmission fluid's condition frequently. When checking the fluid's condition consideration should be given to the type of service the transmission has been subjected to. Under normal conditions the fluid will discolor slightly and should be changed at the recommended service interval. Fluid that is dark in color and smells burnt is usually the result of repeated upshifts and/ or downshifts under heavy load and/or wide open throttle operation. Such demanding operation will require even more frequent oil changes to ensure reasonable transmission life. If the fluid's condition (color and smell) is not indicative of the type of service in which the transmission has been used then a more serious problem exists and should be repaired.

For best performance and life of your TH-700 we recommend changing both the fluid and filter every 15,000 miles (25,00 km) if the vehicle is primarily driven under one (or more) of the following conditions:

- A. High performance applications where the vehicle is regularly driven hard.
- B. In heavy city traffic where the outside temperature regularly reaches 90 F (32 C) or higher.
- C. In hilly or mountainous terrain.
- D. Frequent trailer pulling.

E. Uses such as found in taxi or police car.

If you do not use the vehicle under any of these conditions, change the fluid and filter every 50,000 miles (80,000 km). It is also a good idea to check the torque converter bolts when servicing the transmission.

## TH-700 R4 FLUID CAPACITY

Pan Removal	10.0 pints
Overhaul	23.0 pints

## PRELIMINARY DIAGNOSIS PROCEDURE

1. Check and correct fluid level.
2. Check T.V. cable adjustment. It's a good idea to readjust the T.V. cable prior to test driving or checking line pressures.
3. If engine performance indicates an engine tune-up is required, this should be completed before road testing is completed or transmission correction is attempted. Poor engine performance can be mistaken for transmission problems.
4. Check and correct vacuum lines and fittings.
5. Check and correct shifter manual linkage.
6. Install oil pressure gage and check line pressures. Compare with values from the appropriate table.

## ROAD TEST PROCEDURE

**OVERDRIVE RANGE:** While stopped, position the range selector in the Overdrive position then accelerate. Check for 1-2, 2-3, and 3-4 upshifts. (Shift points will vary with throttle position.) Also, the converter clutch should apply in second or third gear range depending on calibration. (Calibration depends on the components installed in the valve body at the factory.) Check for part throttle downshifts by depressing the throttle to a 3/4 open position. Check for detent downshifts by depressing the throttle to wide open position at various vehicle speeds.

**DRIVE RANGE:** At road speed in fourth gear (Overdrive range), manually shift the transmission to the Drive range. The transmission should downshift to 3rd gear range immediately. Check for part throttle and detent downshifts.

**DRIVE 2:** While in 3rd gear range, shift to manual second, the transmission should downshift immediately. Test for a 2-1 detent downshift.

**LOW RANGE:** Position the selector lever in Low range and check operation. (In some vehicles it may be possible to obtain a 1-2 upshift with selector in this gear range.)

**OVERRUN BRAKING:** Overrun braking can be checked by manually shifting to a lower gear range. Engine R.P.M.'s should increase and a braking effect should be noticed. There is no overrun braking in Fourth (overdrive) range.

**REVERSE:** Position selector in the reverse position and check reverse operation. The TCC does not engage in Reverse.

## ADDENDUM

### Shift Speed Adjustment:

All of our transmissions are built with standard V8 shift points. Some Installations may require adjusting the shift points Up or Down for proper operation. There are two approaches to remedy this problem;

1. Swap the governor from the original transmission (after through cleaning).
2. Use the included (P/N 20248) Governor recalibration kit.

### 117101, 117102 & 117103 Street Level Transmissions Only

#### 1-2 Shift feel:

1-2 shift feel can be made firmer by installing the supplied 1-2 Accumulator spacers. You will have to remove the oil pan and 1-2 accumulator housing to install the spacers (see figure A1).

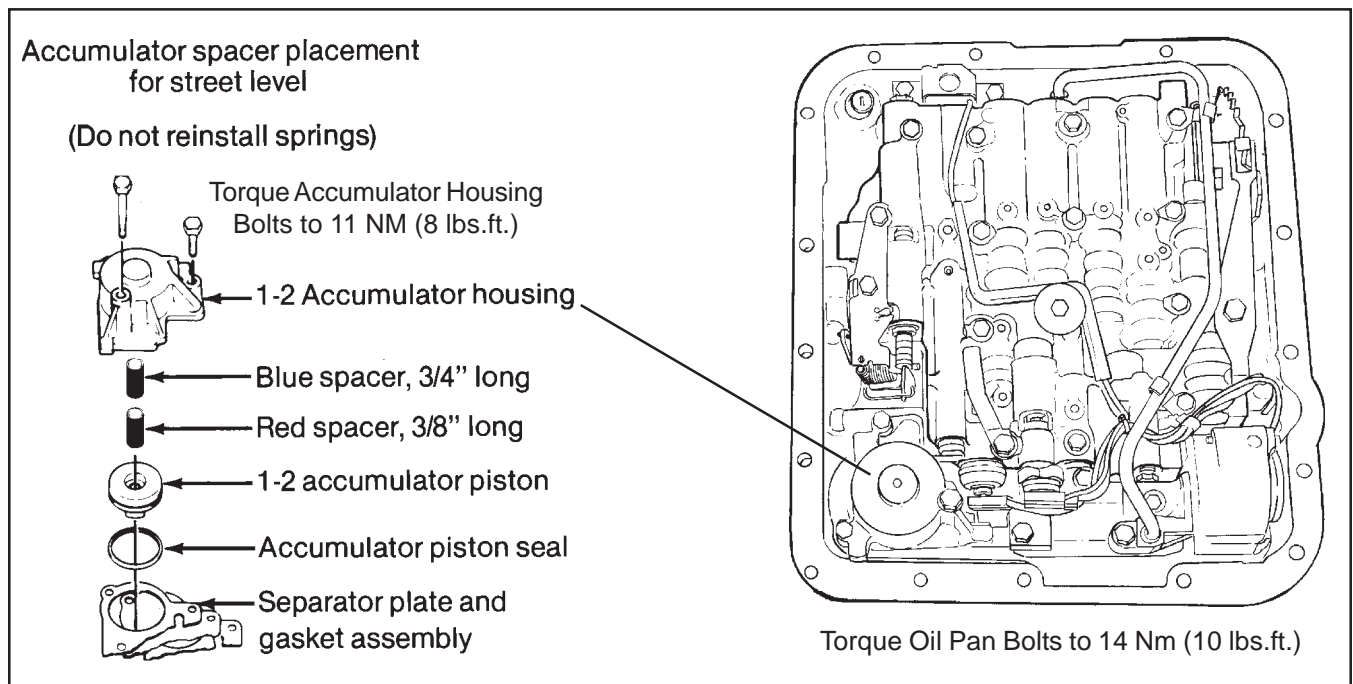


Figure A1. Street Level Accumulator (firmer feel)

# OIL PRESSURE CHECK PROCEDURE

## PRELIMINARY CHECK PROCEDURE

- \* CHECK TRANSMISSION OIL LEVEL
- \* CHECK AND ADJUST T.V. CABLE
- \* CHECK OUTSIDE MANUAL LINKAGE
- \* CHECK ENGINE TUNE
- \* INSTALL 0-300 PSI PRESSURE GAUGE
- \* CONNECT TACHOMETER TO ENGINE
- \* CHECK OIL PRESSURE AS FOLLOWS

### MINIMUM T.V. LINE PRESSURE CHECK:

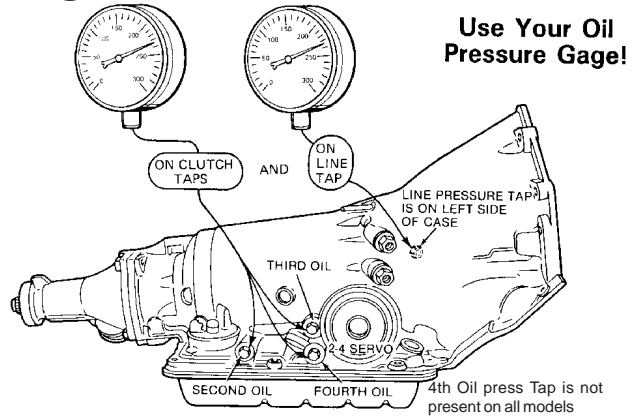
With the T.V. Cable properly adjusted and the brakes applied, take the Line Pressure readings in the Ranges and at the engine RPM's indicated in the chart.

### FULL T.V. LINE PRESSURE CHECK:

Full T.V. Line Pressure readings are obtained by holding the T.V. Cable to the full extent of it's travel then take the Line Pressure readings in the Ranges and at the engine RPM's indicated in the chart.

**CAUTION:** Limit running time at FULL T.V. Pressure to two (2) minutes maximum to prevent overheating.

**CAUTION:** Brakes should be applied at all times.



Oil Pressure Tap Locations

## TH700-R4 TRANSMISSION OIL PRESSURES

RANGE	MODEL	NORMAL OIL PRESSURE AT MINIMUM T.V.		NORMAL OIL PRESSURE AT FULL T.V.	
		kPa	PSI	kPa	PSI
PARK, NEUTRAL, OVERDRIVE, MANUAL 3RD @1000 RPM	ALL MODELS SEE NOTE BELOW	517-586	75-85	1145-1400	166-203
REVERSE @1000 RPM *@2000 RPM	ALL MODELS SEE NOTE BELOW	862-955	100-140	1869-2296	180-340
MANUAL 2ND & MANUAL LOW @1000 RPM	ALL MODELS SEE NOTE BELOW	1517-1689	160-295	1517-1689	160-295

**NOTE:** Oil Pressure at FULL T.V. Pressure depends on the particular T.V. Boost valve and Line Bias Valve arrangement of the unit. The Pressure reading obtained should be within the range shown.

Base Line Pressure is controlled by the Pressure Regulator Valve and Spring. Line Pressure is boosted a fixed amount by the Reverse Boost valve when the selector lever is placed in Second or Low Range. The Line Pressure is also boosted in Neutral, Drive, Drive3 and Reverse with throttle opening because of the T.V. system. The pressure is controlled by the T.V. Cable via the throttle Lever and Bracket assembly to the Valve Body assembly.

The Line Pressure tap is located on the left side of the transmission case above the outside Manual Lever.

FIG. 8 Oil Pressure Check Procedure