

PARTS LIST:

1	LD1 Front Bumper Assembly	6	12mm Hex Nuts
1	Driver/left Frame Mounting Bracket	8	10-1.5mm x 35mm Hex Bolts
1	Passenger/right Frame Mounting Bracket	16	10mm x 27mm OD x 3mm Flat Washers
1	Driver/left Top Corner Filler Panel	8	10mm Lock Washers
1	Passenger/right Top Corner Filler Panel	8	10mm Hex Nuts
1	Driver/left "L" Bracket (center LED light)	2	8-1.25mm x 25mm Hex Bolts
1	Passenger/right "L" Bracket (center LED light)	2	8-1.25mm x 16mm Hex Bolts (LED light bar)
1	License Plate Bracket	6	8mm x 24mm Flat Washers
2	Plastic Plugs for license plate mount	4	8mm Lock Washers
6	Sensor Hole Plugs	2	8mm Hex Nuts
10	Nylon Wire Ties	6	6mm x 20mm Button Head Bolts
1	Sensor Cover Kit	4	6mm x 18mm x 1.6mm Flat Washers
3	Dodge Wire Harnesses	4	6mm x 12mm OD x 1.5mm Flat Washers
6	Retaining Rings	4	6mm Lock Washers
6	15.5mm x 25mm Centering Foam Washers	2	6mm Nylon Lock Nuts
6	12-1.75mm x 35mm Hex Bolt	1	6mm Allen Wrench
12	12mm x 32mm x 3mm Flat Washers	12	4mm x 10mm Button Head Bolts
6	12mm Lock Washers	1	4mm Allen Wrench

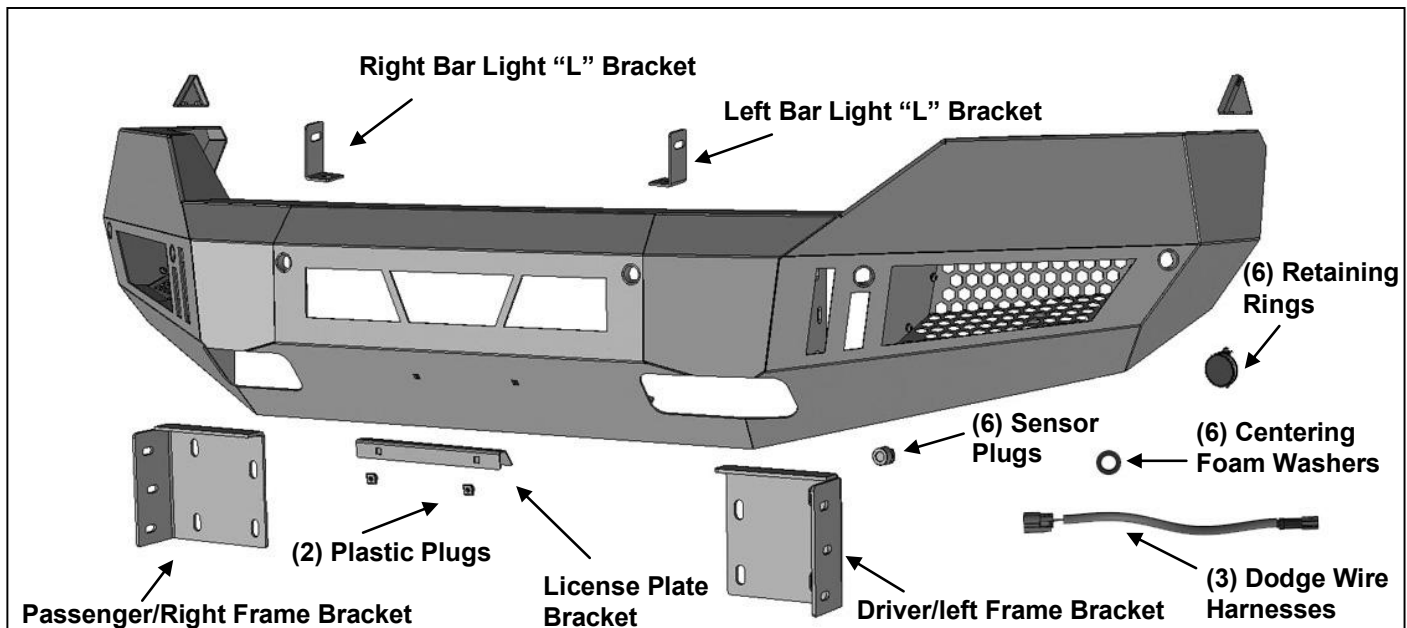

PROCEDURE:

REMOVE CONTENTS FROM BOX. VERIFY ALL PARTS ARE PRESENT. READ INSTRUCTIONS CAREFULLY BEFORE STARTING INSTALLATION. BUMPER IS HEAVY, ASSISTANCE IS HIGHLY RECOMMENDED TO AVOID POSSIBLE INJURY OR DAMAGE TO THE VEHICLE.

1. Remove the license plate and bracket. Remove lower air dam, **(Figure 1)**. **NOTE:** Air dam is attached with many 2pc retaining clips. Pry up center of pin to release and remove clips.
2. On models with factory fog lights and/or sensors, unplug wiring harness, **(Figure 2)**. Release the harness from the clips attached to the back of the bumper and move harness away.
3. On models equipped with tow hooks, remove the tow hooks and mounting brackets. **NOTE:** Tow hooks cannot be reinstalled.
4. Next, remove the plastic fascia fill panel between the headlights and the top of the bumper. **NOTE:** Release inner fender liner to access hardware attaching the ends of fascia panel to the bottom of the

front fenders, (**Figures 3 & 4**). On some model years, it may be necessary to temporarily remove the grille to remove the fascia or 1pc plastic bumper cover.

5. Place blocks or jack stands under the bumper to support it during mounting bolt removal. Once the bumper has been safely supported, remove the (3) hex nuts attaching each bumper bracket to the end of the frame, (**Figure 5**). **WARNING!** Assistance is required to hold bumper in place during hardware removal to prevent the bumper from falling. Slide the bumper assembly off of the end of the frame.
6. Next, remove the plastic inner support blocks from the bottom of the headlights, (**Figure 6**).
7. Select the driver/left side Frame Mounting Bracket, (**Figure 7**). **NOTE:** Holes in mounting flange on end of frame are two sizes (3-large, 1-small). Attach the Bracket to the end of the frame with (3) 12mm x 35mm Hex Bolts, (6) 12mm Flat Washers, (3) 12mm Lock Washers and (3) 12mm Hex Nuts. Use (1) 10mm x 35mm Hex Bolt, (2) 10mm Flat Washers, (1) 10mm Lock Washer and (1) 10mm Hex Nut to attach the Bracket to the smaller, top inner mounting hole in the bumper flange, (**Figures 7 & 8**). Repeat Step to install the passenger/right Frame Bracket.
8. Sensors must be installed in Bumper, (if equipped), before installing Bumper Assembly.

Models without bumper sensors:

- a. Select the included (6) Rubber Plugs.
- b. From behind bumper, push plugs into sensor mounting holes.

Models with bumper mounted sensors:

- a. Remove the factory sealing washer from the sensor. Attach (1) Centering Foam Washer, (**Figure 9**), onto the front of the sensor, (**Figure 10**).
- b. Push the sensor in from the back of the Bumper until it is flush with the sensor sleeve. **NOTE:** Sensor tabs may need to be trimmed to fit sensor inside the sensor sleeve. Push (1) Retaining Ring into the sensor sleeve to secure the sensor in place, (**Figures 11 & 12**).
- c. Repeat the previous steps for all six sensors.
- d. Starting on the driver side, run the OE sensor wire harness through the bumper cutouts. Connect the first three driver side sensors to the OE sensor wire harness, (**Figure 12**).
- e. Use the provided wire harness extensions to connect the remaining three passenger side sensors to the OE sensor wire harness, (**Figure 13**).
- f. Use the provided Wire Ties to secure the Wiring Harnesses to the back of the Bumper.
9. If front license plate is required, attach the License Plate Bracket to the holes in the bumper with the included (2) 6mm x 20mm Button Head Screws, (4) 6mm x 18mm Large Flat Washers and (2) 6mm Nylon Lock Nuts. Insert (2) Plastic Plugs into the square holes in the Bracket. Reuse the factory screws to attach the license plate to the plastic plugs, (**Figure 14**).

Center LED light installation as supplied with bumper or sold separately.

- c. Select the L/R "L" Brackets, (**Figure 15**). Attach the Brackets to the top of the (2) mounting tabs welded onto the back of the bumper with the included 8mm x 25mm Hex Bolts, (4) 8mm Flat Washers, (2) 8mm Lock Washers and (2) 8mm Hex Nuts. Leave loose at this time.
- d. Attach the LED light assembly to the "L" Brackets with the included (2) 8mm x 16mm Hex Bolts, (2) 8mm Lock Washers and (2) 8mm Flat Washers. Do not fully tighten hardware at this time. **IMPORTANT:** "L" Brackets are designed for 8mm light mounting hardware only. Modify "L" Brackets if necessary or use brackets supplied by your light manufacturer if possible to install hardware larger than 8mm.
- e. Follow light manufacturer's instructions to properly wire light once bumper has been installed.

LED light installation at ends of bumper as supplied with bumper or sold separately.

- f. Insert light into opening and up to mounting slots. Check for clearance between front and back of light. If necessary, remove screen from back of opening, (**Figure 16**).
- g. Follow the light manufacturer's instructions to attach (1) light to the center slot or (2) lights to the inner and outer slots in the top of the light opening, (**Figure 16**). **IMPORTANT:** On two light systems, attach the flood light to the outer slot and the spot light to the inner slot.
- h. Repeat the above steps for passenger side light installation.
- i. Follow light manufacturer's instructions to properly wire light once bumper has been installed.
10. With assistance, position the LD1 Bumper Assembly up to the outside of the Frame Brackets. Temporarily support the weight of the Bumper. **WARNING:** To avoid possible injury or damage to the vehicle, do not proceed until the Bumper is fully and safely supported. **NOTE:** It may be easier to install

accessory lights before installing the Bumper, (models with tow hooks for example). See **Step 9** regarding lighting if desired.

11. Attach the mounting tab on the back of the driver/left side of the Bumper to the Frame Bracket with (3) 10mm x 35mm Hex Bolts, (6) 10mm Flat Washers, (3) 10mm Lock Washers and (3) 10mm Hex Nuts, (**Figures 17 & 18**). Do not fully tighten at this time. Repeat this **Step** to attach the passenger/right side of the Bumper to the Frame Bracket.
12. Select the driver/left triangle shaped Top Corner Fill Panel, (**Figure 19**). Attach the Panel to the top of the bumper with (2) 6mm x 20mm Button Head Screws, (2) 6mm Lock Washers and (2) 6mm x 12mm Small Flat Washers, (**Figures 19 & 20**). **NOTE:** The Driver and passenger side Top Corner Fill Panels look similar but are unique. The side of the triangle with the small notch, (**Figure 19**), will go toward the rear, (toward the fender). Repeat to install the passenger/right Top Corner Fill Panel.
13. Level and adjust the bumper and fully tighten all hardware.
14. Do periodic inspections to the installation to make sure that all hardware is secure and tight.

To protect your investment, wax this product after installing. Regular waxing is recommended to add a protective layer over the finish. Do not use any type of polish or wax that may contain abrasives that could damage the finish. Mild soap may be used to clean the Bumper assembly.

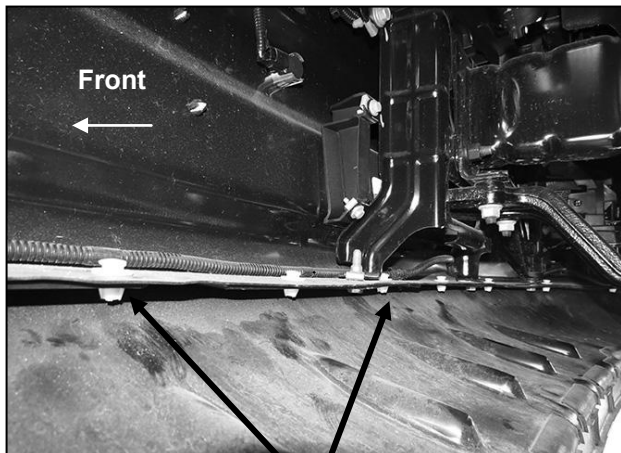

(Fig 1) Release clips (arrow) to remove air dam (pictured from behind bumper-tow hook equipped)



(Fig 2) Unplug lights and sensors if equipped. Unplug harness to bumper and move harness



(Fig 3) Pull back fender liner to locate fascia attachment at bottom of front fender



(Fig 4) Remove fascia body panel from top of bumper

Driver Side Installation Pictured

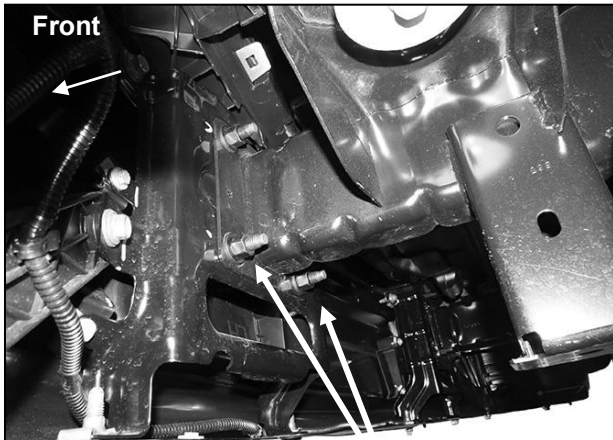

(Fig 5) Remove (3) factory hex nuts from each side

12mm x 35mm Hex Bolt
(2) 12mm Flat Washers
12mm Lock Washer
12mm Hex Nut

10mm x 35mm Hex Bolt
(2) 10mm Flat Washers
10mm Lock Washer
10mm Hex Nut

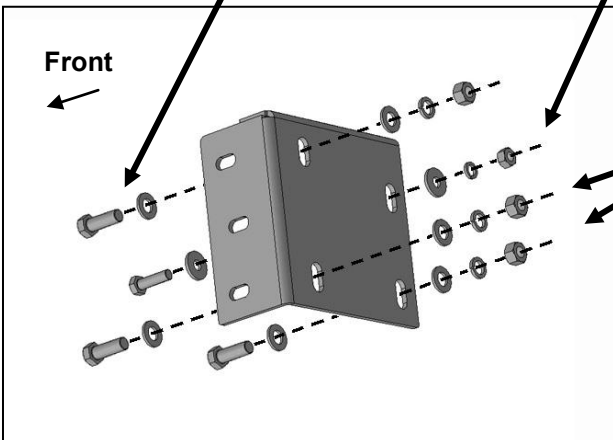

(Fig 7) Attach driver/left Bracket to end of frame

(2) 12mm x 35mm Hex Bolts
(4) 12mm Flat Washers
(2) 12mm Lock Washers
(2) 12mm Hex Nuts

10mm x 35mm Hex Bolt
(2) 10mm Flat Washers
10mm Lock Washer
10mm Hex Nut

(3) 12mm x 35mm Hex Bolts
(6) 12mm Flat Washers
(3) 12mm Lock Washers
(3) 12mm Hex Nuts

WARNING! Do not crawl under bumper unless the bumper is properly supported on blocks or stands or the bumper may fall.

WARNING! Do not remove bumper bolts unless the bumper is properly supported on blocks or stands or the bumper may fall.

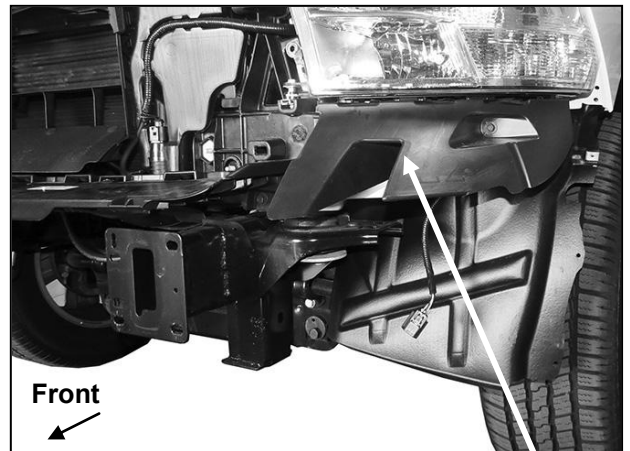

(Fig 6) Remove plastic block from below headlight

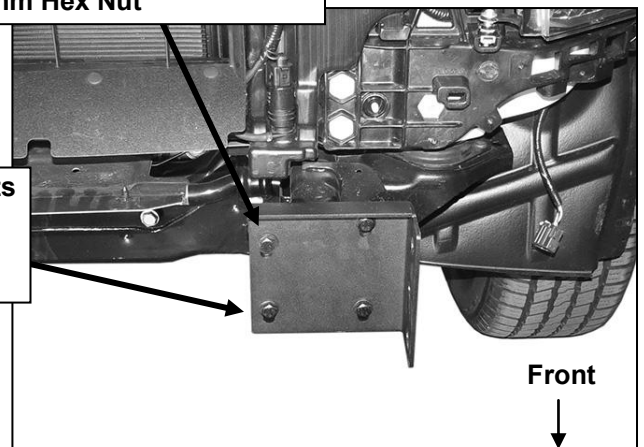

(Fig 8) Driver/left Mounting Bracket installed

Driver Side Installation Pictured



(Fig 9) Centering foam washer

Remove factory sealing washer from sensor

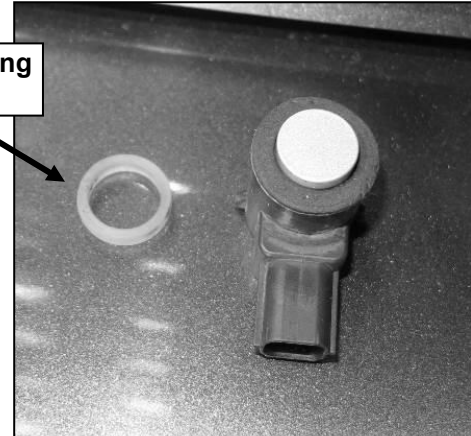

(Fig 10) Centering foam washer on Parking sensor

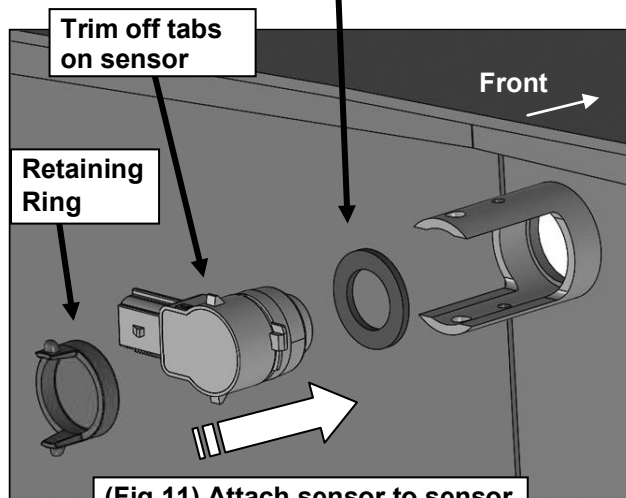

(Fig 11) Attach sensor to sensor sleeve behind bumper

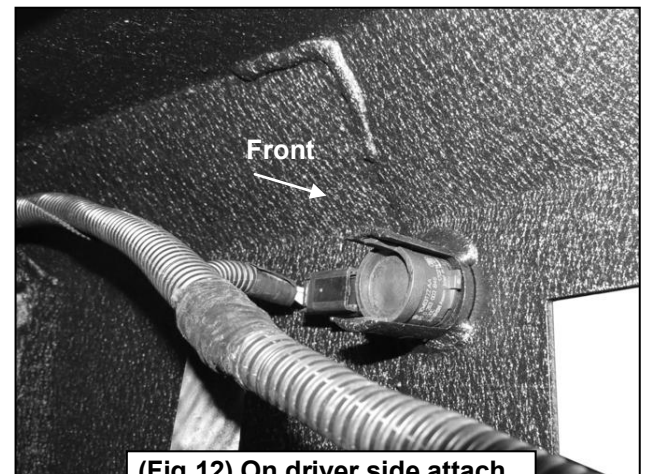

(Fig 12) On driver side attach sensors to OE wire harness

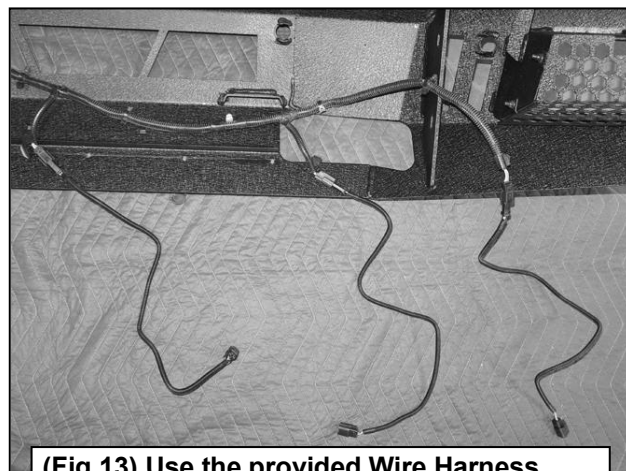

(Fig 13) Use the provided Wire Harness extensions for the Passenger side sensors

Driver Side Installation Pictured

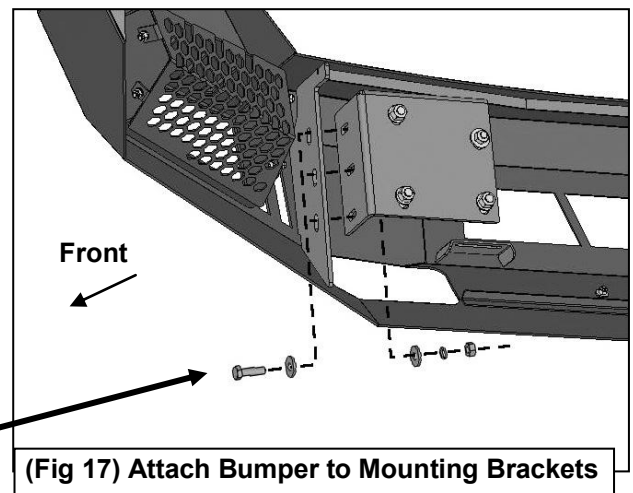
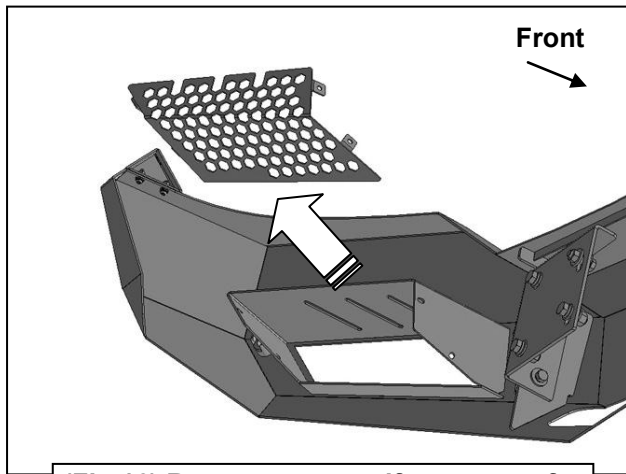
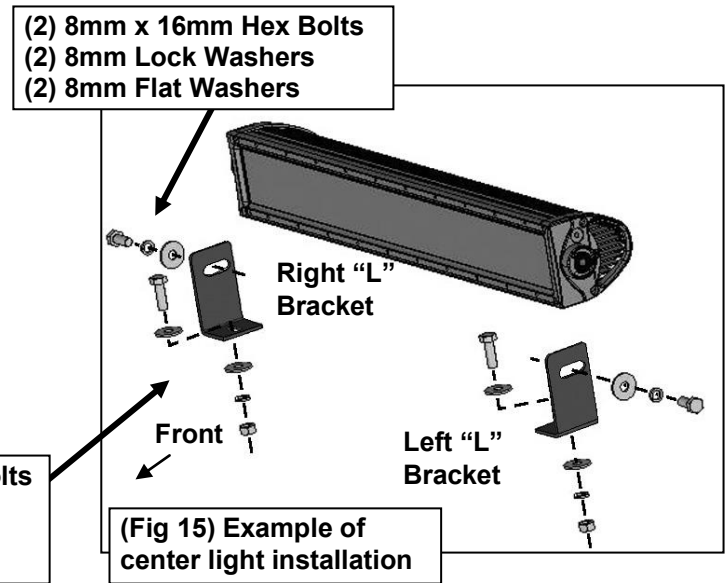
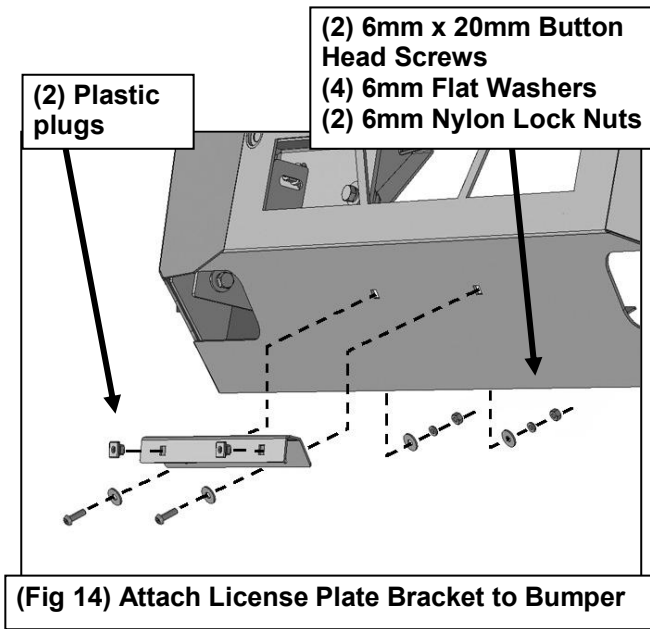

Driver Side Installation Pictured

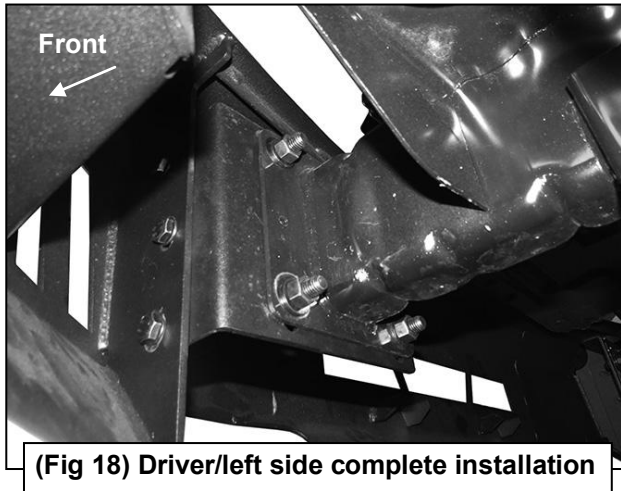

WARNING! Do not crawl under bumper unless the bumper is properly supported on blocks or stands or the bumper may fall.

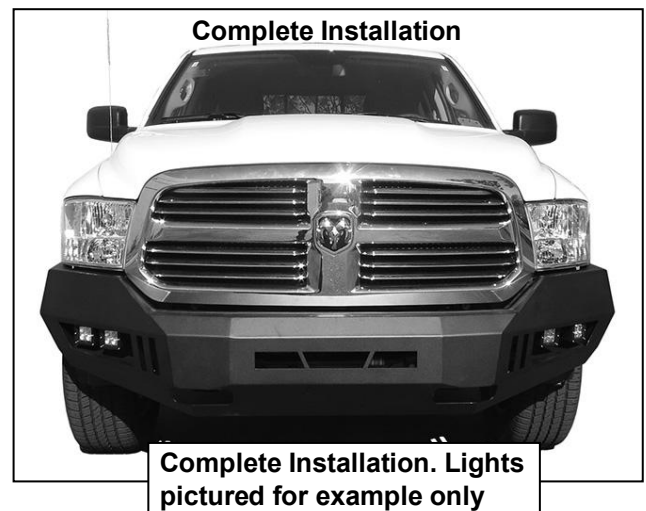
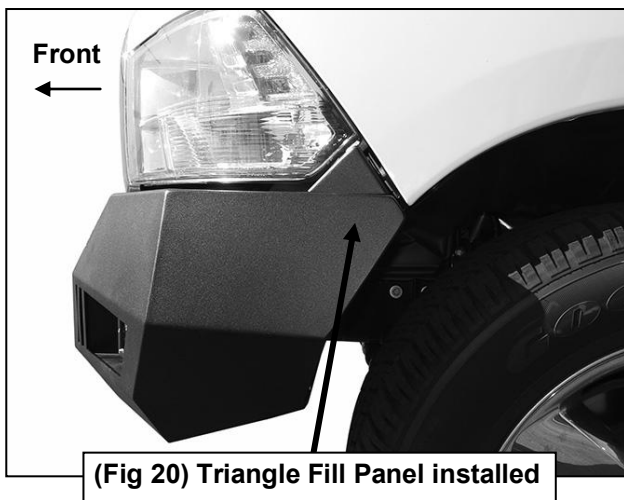
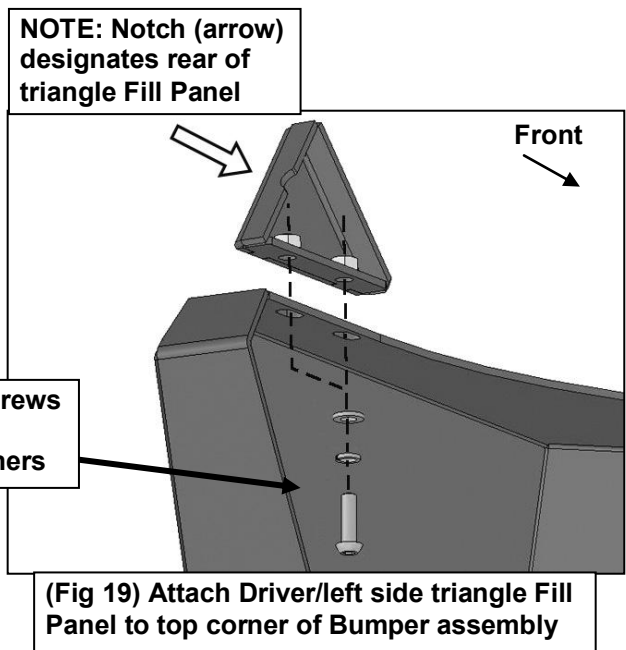

WARRANTY POLICY & PROCEDURE

Contact your Body Armor 4x4 Distributor or Body Armor 4x4 directly regarding any issue prior to removing product from vehicle. If it appears said product is warrantable, you will be given a Return Authorization Number (RA #) and asked to return said product freight pre- paid. The RA # must appear on the outside of the carton/box of any returned product. Unauthorized returns will be refused. RA # must be given by Body Armor 4x4 in advance of return.

BODY ARMOR LIMITED LIFETIME WARRANTY

Body Armor 4x4 (BA) warrants to the original purchaser that these products will be free from defects in material and workmanship prior to shipping and/or installation for the life of the product. This non-transferable limited lifetime warranty does not cover damage or impairment in any part due to misuse, improper installation, accident or contact with on-road or off-road hazards, product modification, improper or inadequate cleaning and/or maintenance. All other warranties and representations express or implied are hereby disclaimed, including fitness for merchantability and buyer's intended use or purpose.

BA products are built and sold for highway and off-road use. The original purchaser assumes all risks as to the selection, suitability and performance of all goods and products purchased.

BA's sole and exclusive obligation under this warranty shall be to repair or replace the item(s) and their discretion and BA will not issue any credit or refund to the consumer. Proof of purchase is required on all warranty claims. BA may require pictures to diagnose the warranty claim and may require the product(s) be returned if determined by BA to be necessary. If a return is required then a RGA number will be issued by BA. Any item arriving to BA without a valid

RGA number will be refused and sent back. Upon evaluating the RGA and no valid warranty claim is made, the RGA will be returned to the consumer at their expense or disposed by BA after 60 days. BA will not be responsible for incidental charges such as removal, installation, shipping costs or lost during transit. Any items that are ordered in error, refused or cancelled are not considered a valid warranty claim and cannot be returned to BA.

WARRANTY PROCESS

Contact an authorized BA dealer to initiate warranty process. Authorized dealers must contact BA to assist in evaluating the warranty claims. Valid warranties will have a RGA issued. Once issued the dealer will request the product be returned to BA facilities. Products purchased through an authorized BA dealer will be refunded and/or credited by that BA dealer.

Warranty contact: orders@bodyarmor4x4.com

Return address: Body Armor 4x4, 1050 N. Vineyard Ave. Ontario CA, 91764, P: 951-808-0750

FINISH WARRANTY

The finish is warranted to be free of defects for a period of 3 years from date of purchase. Product(s) that have been abused, altered, incorrectly installed or used in competition are void of said warranty. Surface rust, pitting or discoloration is a direct result of improper maintenance is not covered by this warranty. It is the responsibility of the owner to preserve and maintain the finish of their product(s). In areas where high concentrations of road salts and other corrosive agents are used, rust or damage to the finish may occur if BA product(s) are not properly maintained. Lack of proper maintenance in these areas may void the finish warranty. See below for routine maintenance tips and recommendations.

**PRODUCT CARE AND MAINTENANCE**

Textured coat finished should be cleaned ONLY with a mild soap on a damp sponge.

BA recommends wiping down the product with a light coat of lubricate (i.e. WD40) periodically to maintain its luster.

DO NOT apply polish or wax that requires buffing for removal as this may damage the finish.

DO NOT coat the product with any type of shine such as Tire Shine or glossy aerosol or gel. This can cause discoloration, staining or bubbling.